

**SCOTTSMAN<sup>®</sup>**

**SERVICE MANUAL**

**MF 102  
SPLIT**

**Modular superflaker  
remote high side**

REV. 03/2002

**TABLE OF CONTENTS**

Table of contents	page	2
Specifications		3-4
<b>GENERAL INFORMATION AND INSTALLATION</b>		
Introduction		5
<b>FOR THE INSTALLER</b>		
Installation Limitations		6
Select the locations		6
Storage bin or ice room		6
Ice Chute		6
Ice level control		6
Locate the nameplate		6
Electric control box		6
Refrigeration installation		6
Electrical connection		7
Water supply and drain connection		7
Final check list		8
<b>OPERATING INSTRUCTIONS</b>		
Start up		9
Start up consist of		9
OPERATION		9
Water		9
Ice		9
Refrigeration		10
<b>COMPONENT DESCRIPTION</b>		
Refrigeration		11
Evaporator		11
Electric Control and Safety devices		11
<b>REMOVAL AND REPLACEMENT PROCEDURE</b>		
Water reservoir		13
Bearing and Breaker		13
Auger		14
Evaporator		14
Gear Reducer		15
Drive Motor		15
<b>SERVICE DIAGNOSIS</b>		
		16
<b>WIRING DIAGRAMS</b>		
		17-18
<b>MAINTENANCE AND CLEANING</b>		
In place cleaning		19
Maintenance		19-20

## SPECIFICATIONS

### MF 102 - AIR & WATER COOLED MODEL

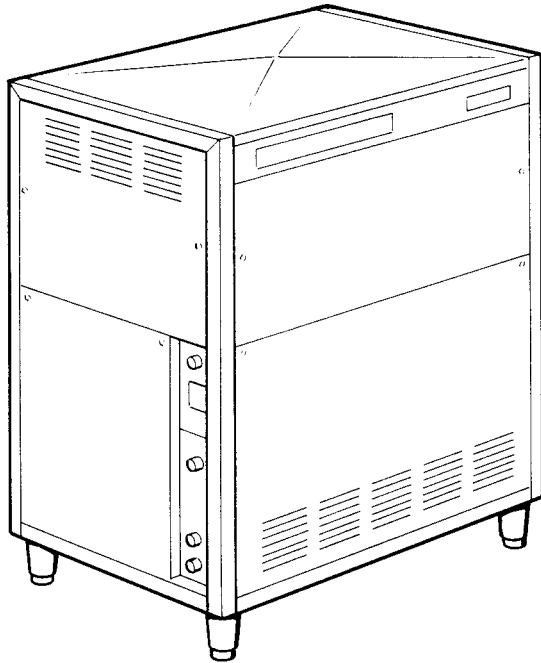

**Important operating requirements:**

- Remote condensing unit capacity (Remote High Side):  
16,000 Kcal/hr - 18600 Watt - 59,000 BTU/hr  
+35 °C Condensing temperature  
-25 °C Evaporator temperature

- Refrigerant: R 404 a
- Liquid line pressure: 16 bar (225 psig)
- Suction line pressure: 1.6 ± 0.1 bar (22 ± 0.2 psig)

	MINIMUM	MAXIMUM
• Air temperature	10°C (50°F)	40°C (100°F)
• Water temperature	5°C (40°F)	35°C ( 90°F)
• Water pressure	1 bar (14 psi)	5 bar (70 psi)
• Electrical voltage variation	-10%	+10%
voltage rating specified on nameplate		

## ICE MAKING CAPACITY

**AIR COOLED MODELS**

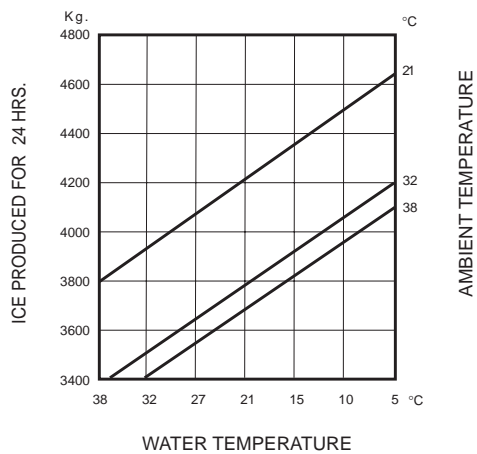

**WATER COOLED MODELS**

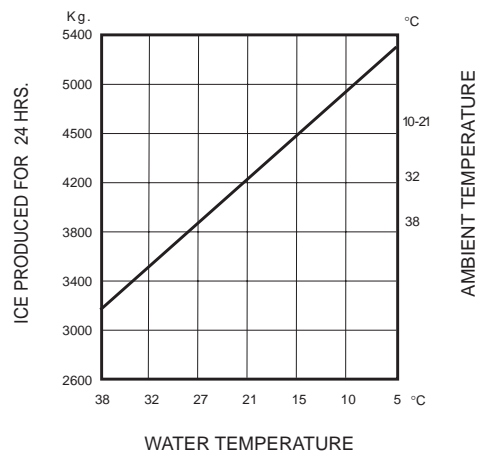

**SPECIFICATIONS (CONT'D)**

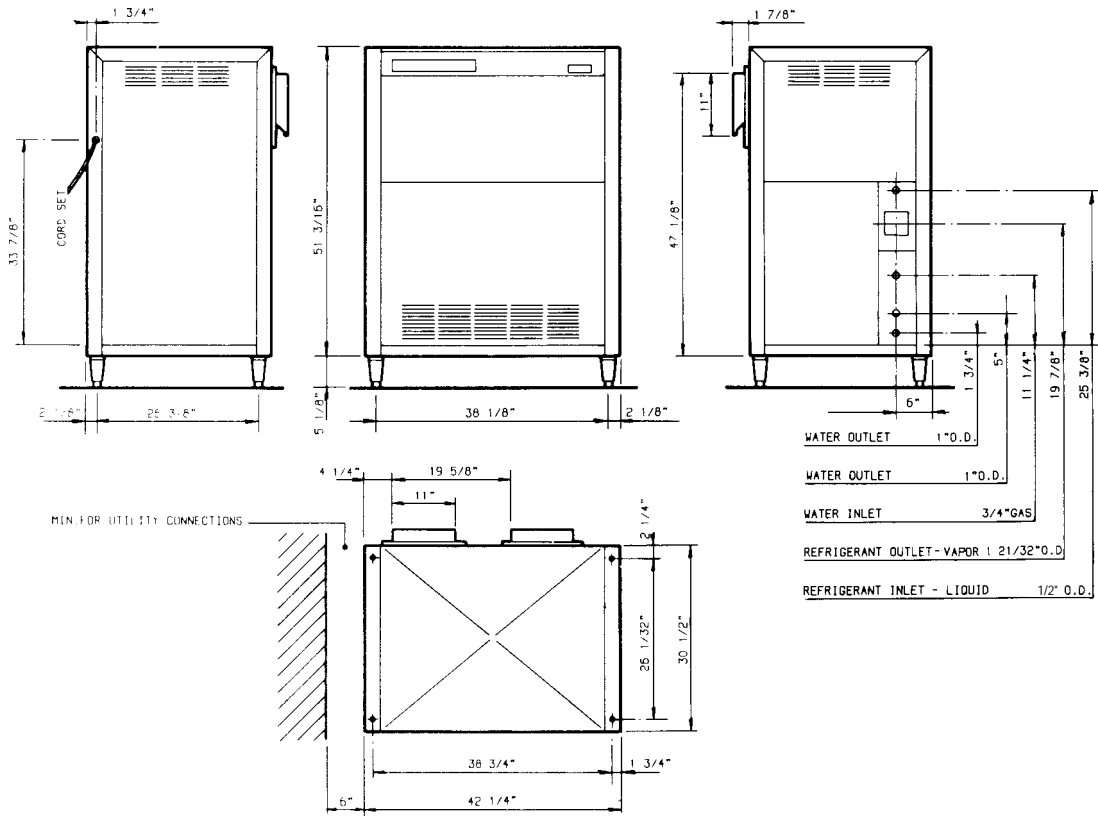

**MF 102 - MACHINE SPECIFICATIONS**

Basic electrical	Max Fuse Size	Refrigerant	Drive Motor	Cooling Req. at -25°C / +35°C	Ice Type
V230/400/50/3+N	Amps 15	R 404 a	230-400/50/3 - rpm 1400 3.8 - 2.3 A 0.55 Kw (2 installed)	Kcal/h 16.000	SUPER FLAKE

## GENERAL INFORMATION & INSTALLATION

### INTRODUCTION

The service manual you are reading is intended to provide you and the maintenance or the service technician, with the information needed to install, start-up, clean, maintain and service this ice system.

The MF 102 is the freezer portion of a commercial ice making equipment.

It is designed to be connected to the condensing

section of a refrigeration system, specifically a supermarket R 404 a system. It consists of two evaporators, two gear reducers, two drive motors, two thermostatic expansion valves, two evaporator press. control valves (EPR) encased in a vertical style cabinet which is in a stainless steel finish and one electrical control box.

SCOTSMAN ICE SYSTEMS are designed with the highest regard for safety and performance.

## FOR THE INSTALLER

### INSTALLATION LIMITATIONS

The MF 102 is designed for indoor installations only. The machine must also be in a controlled environment where the air temperature does not fall below 10°C or go above 40°C. The water temperature must be between 5°C and 35°C. The electrical power supply must not drop below or above nameplate voltage.

FRIMONT assumes no liability or responsibility of any kind for products manufactured by FRIMONT/SCOTSMAN, that have been altered in any way, including the use of any parts and/or other components not specifically approved by FRIMONT/SCOTSMAN.

FRIMONT reserves the right to make design changes and/or improvements at any time. Specifications and designs are subject to change without notice.

### SELECT THE LOCATION

The unit can only be installed indoors within the limitations described on page 3. The ice machine will have to be connected to the remote High Side Condensing Unit) or to the building refrigeration system at R 404 a. In this latest case check to be sure that the system has enough extra capacity to handle a minimum of additional 16.000 Kcal/hr with +35°C liquid line temperature (Assume a -25°C evaporator temperature).

### STORAGE BIN OR ICE ROOM

An Ice Room will be presumably the ice storage choice, then according to the ice application, this can be refrigerated not refrigerated; a weight/volume ratio of 1.8 cu.m. per ton must be taken into consideration for correct ice storage room design which, in any case, should be dimensioned to accommodate a minimum of 16 hrs ice production.

### ICE CHUTE

Ice chute extensions or ice deflectors if not pre-set must be arranged to convey the ice from the outlets of the ice maker to the ice storage area. Stainless steel is an excellent material where its cost is not prohibitive. Angles or edges of less than 45°C should not be used. Ice will cling to the surface and either melt excessively or jam in the ice chute. The sharper the drop, the better. If straight down, do not insulate unless necessary. Ice chute and/or ice deflector ends, whenever possible, should be preset with grommets holes so that bin thermostat capillary tube can be inserted in them to be correctly positioned.

### ICE LEVEL CONTROL (BIN THERMOSTAT)

Thermostat/sensing bulb must be positioned so that its end extend out the ice chute openings and get easily in contact with the cone formed by the ice deposited in the storage room, before anyway that ice builds-up in the chute. Thermostat capillary tube and sensing bulb is coiled behind the front fascia, it must be routed to follow the ice chutes or ice deflectors and protrude for a certain

extension beyond the ice discharge opening in the storage room. Use caution when routing this capillary to prevent kink or to bent it excessively, this is 3,5 mt. long.

Coil excess capillary inside ice maker cabinet. Tape coil to prevent vibration against another part.

### LOCATE THE NAMEPLATE

The nameplate is located on the back panel of the machine and contains the electrical characteristics particular to the unit being installed.

### ELECTRIC CONTROL BOX

The ice maker control box consist of a plastic box containing one terminal block, one timer with control knob, three warning lights, one contactor, two current limiters for drive motors and one time delay device.

### REFRIGERATION INSTALLATION

The skills of a refrigeration technician are required to connect the ice maker to the building refrigeration system or to a separate condensing unit (remote high side) with necessary set-up to minimize chances of accidents and to correctly handle the refrigerant load.

#### CAUTION

##### Connect to a R 404a system

- LIQUID LINE (dia. 12 mm), connection is 1/2"

- SUCTION LINE (dia. 42 mm), connection is 21/32"

Local codes must be observed.

A P-trap should be installed where there will be more than 3 mt (10') of vertical rise in the suction line.

A manual shutoff valve should be installed on the liquid line, located in position where it can be promptly reached and easily turned.

- It is good practice to install on the liquid line also a solenoid shutoff valve, with electrical connection to the contactor in the ice maker control box which relays on the various safety control.

- On suction line it is advisable to install the following controls, in the order as they are mentioned, which are imperative when the ice maker is part of a multiple installation.

- **A suction line manual shutoff valve to help service operations.**

Remember, tubing, safety valves and protective devices should be placed into the system, where they will produce operating efficiency, permanency and safety.

### ELECTRICAL CONNECTION TO THE ICE MAKER CONTROL BOX

Locate the nameplate for the current requirements and then determine the wire size and type per the Local Electric Code. The unit requires a solid ground connection and should be on its own electrical circuit individually fused.

Voltage, when the units is under full load, must remain within the limitations listed on page 3.

### LOW VOLTAGE CAN CAUSE EQUIPMENT MALFUNCTION AND/OR DAMAGE.

All external wiring should conform to local electrical codes.

Usually the services of a licensed electrician will be required.

The control box can be remotised. If so it must be positioned where it can be constantly kept under control and easily hand reached.

It must be electrically connected to the ice maker junction box and to the condensing unit control box (See wiring diagrams as weel).

### WATER SUPPLY

The recommended water supply line is a 1/2" O.D. copper tubing or flexible hose with a minimum operation pressure of 1 bar and maximum of 5 bar. Connect to cold water inlet fitting, 3/4" male at the left side of the unit. Install a shut off valve in an accesible space between the ice makers and the water supply.

### DRAIN

All drains are of the gravity type and must have a minimum of 20 cm fall per meter of horizontal runs. The drains must be installed to conform to local plumbing codes. It is advisable to use rigid tubing fro drains to be connected to the drain fitting of (25 mm) 1" O.D. at the left side of the unit.

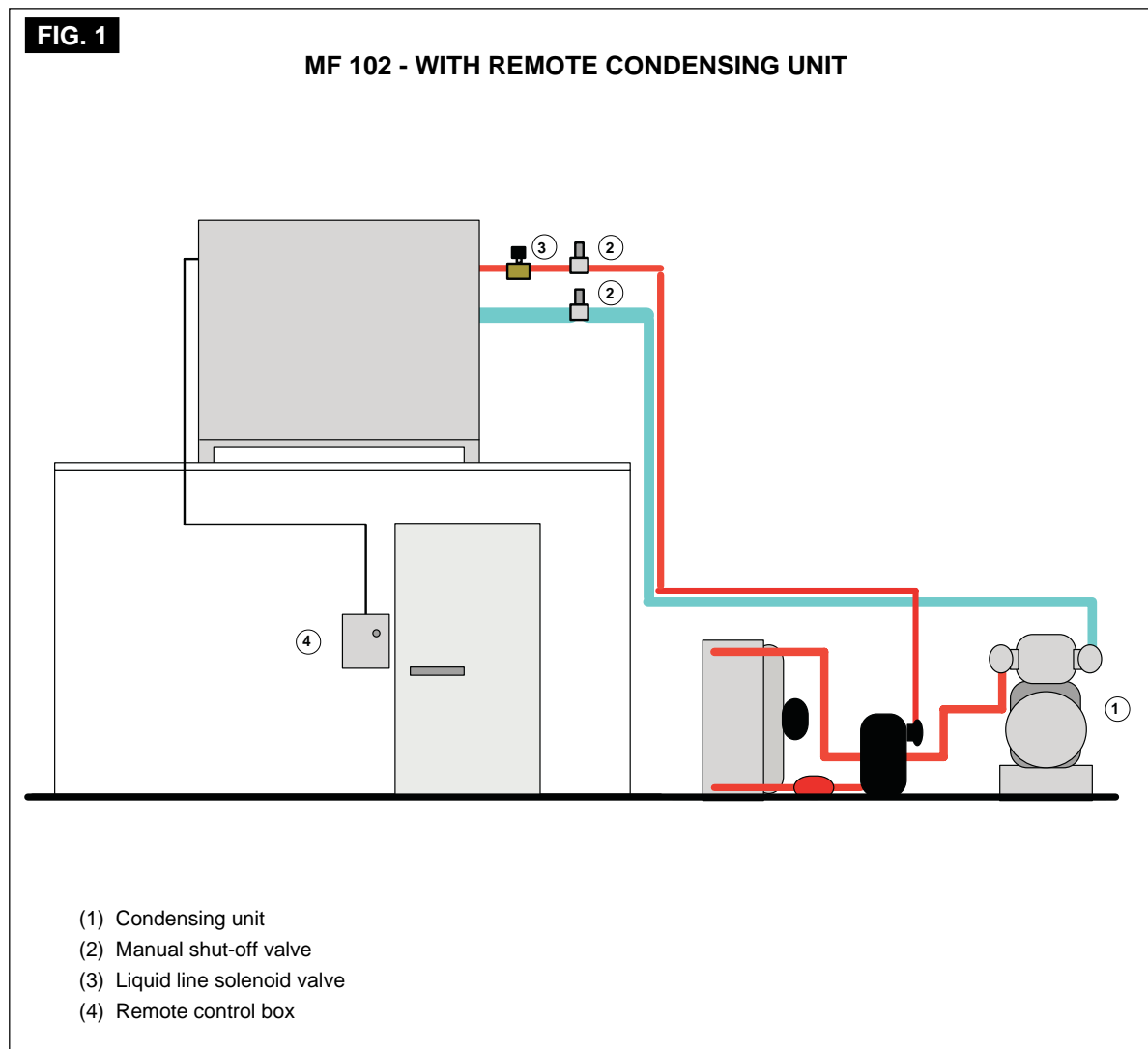

**FINAL CHECK LIST**

1. Is the unit installed where the air and water temperatures are within and will remain within the limitations for the unit?
2. Is there 15 cm clearance at the rear of the machine for utility connections?
3. Has the water supply line been checked for pressures between 1 bar and 5 bar?
4. Has the unit been levelled?
5. Has the shipping material been removed from inside the cabinet?
6. Have the electrical connections been made to the electrical control box and there is an electrical service disconnect within sight of the installed machine?
7. Have the drains and water supply been installed and checked for leaks and a water shut-off valve installed near the unit?
8. Has the refrigeration supply been installed and checked for leaks and guarded against vibrations or rubbing?
9. Have all the wires been checked for looseness and tightness?
10. Is the dial of delay timer, set on 5 minutes?
11. Has the voltage been tested and checked against the nameplate rating?
12. Has gear boxes oil level been checked through corresponding sight glasses?
13. Has the warranty registration card been properly filled-out and mailed to FRIMONT?
14. Has the owner been given the service manual and been instructed on how to maintain the icemaker?
15. Has the owner been given the name and telephone number of the local SCOTSMAN service agency?

## OPERATING INSTRUCTIONS

### START-UP

**WARNING - The evaporator auger drive motor is threephase, so, at the unit start-up, care must be taken to ensure of the correct rotation direction of auger. In case of wrong rotation interchange the phases by interchanging the lead wire connections of main cord. AUGER MUST TURN COUNTER-CLOCKWISE.**

1. Remove the front and side panels.
2. Open the water valve and observe that the two float reservoirs fill up with water and shut-off. Observe that tubes from reservoirs to the evaporators are filled with water and that there are no air-pockets in them. Check for leaks.
3. Remove cover from separate control box and temporary set dial of delay timer to zero position.
4. Move the main switch to ON position and turn counterclockwise the timer knob of control box to start the icemaker operations. The green light on control box will glow. Observe immediately if auger drive motor pulley rotate is the direction as illustrated here below.
5. If auger drive motors are rotating correctly, move the timer delay to 5 minutes position. Unit must be on delay control set on 5 minutes and will always resume operation when 5 minutes delay is elapsed.

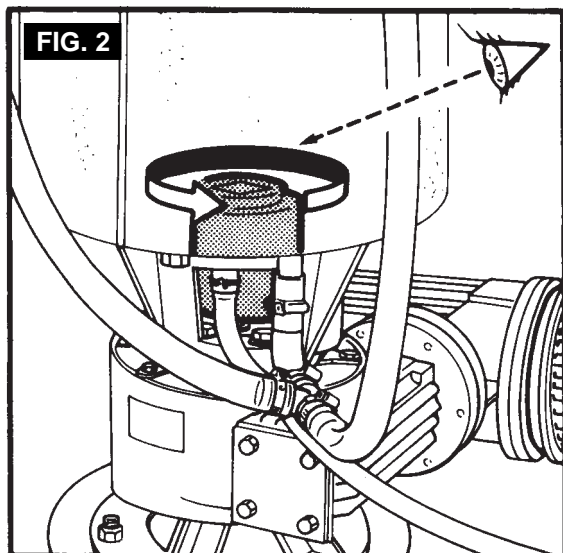

6. The ice maker is now operating. The liquid line valve opens.\* The two drive motors runs. Within short time, begin to make ice in both freezers.
7. Water flows from the water reservoirs and the float drop, letting in more water.
8. The liquid sight glass should remain full and the low side pressure will be about 1 bar.
9. With the clamp ammeter measure both Drive motor amps. At 400 V - 50 Hz - 3 ph. drive motor amp draw should not exceed the value of Amp 1.1 each.
10. Check the system very carefully for any refrigerant leaks, repair as needed.
11. There are no adjustment to make replace the panels.

### START UP CONSIST OF:

The drive motor contactors become energized connecting power to the windings of the two drive motors.

Both drive motors start, rotating the freezer augers counterclockwise and connecting power to the **liquid line solenoid valve\*** and to contactor coil of condensing unit.

The liquid line solenoid valve\* opens and the refrigerant flows to the thermostatic expansion valves into the two evaporators.

In the evaporators water changes into ice and it is lifted up to be extruded through the ice breakers by the rotating augers.

\* Not factory supplied

### OPERATION

#### WATER (Fig. 3)

Water enters the ice making unit through the 3/4" gas male fitting at the left side of the cabinet, goes to the two water reservoirs which it enters through their float valves. The water then goes out the bottom of the reservoir to the bottoms of the evaporators where then it enters to surround the rotating auger. Water inside the evaporators is changed into ice by the low temperature caused by the evaporating refrigerant circulating into the freezer coil serpentine.

#### ICE

A stainless steel auger within the freezers is powered by a separate drive motor through a

speed reducer and the rotating auger carries the ice upward to the Ice Breaker, where excess water is pressed out of the ice, as it is extruded or flaked out through the ice breaker. The flake ice into the spout is diverted out through the ice discharge opening. Moving the manual ON-OFF switch of the Ice Maker, to the ON position the automatic and continuous icemaking process start after a delay if 5 minutes. When the ice touches the Thermostatic Control Bulb, the sensing bulb shuts - off the icemaking process.

the ice machine. Liquid refrigerant passes first through the sight glass then through two thermostatic expansion valves, which meter the liquid refrigerant to the evaporator coils. In the evaporator coil the refrigerant boils off (evaporates) and absorbs heat. It then moves into the two EPR valves and out of the ice maker to return via shut-off valve\* and suction line, to the remote high side system.

**REGRIGERATION (Fig. 4)**

The remote high side supplies high pressure liquid refrigerant to the liquid line connection on

\* Not factory supplied

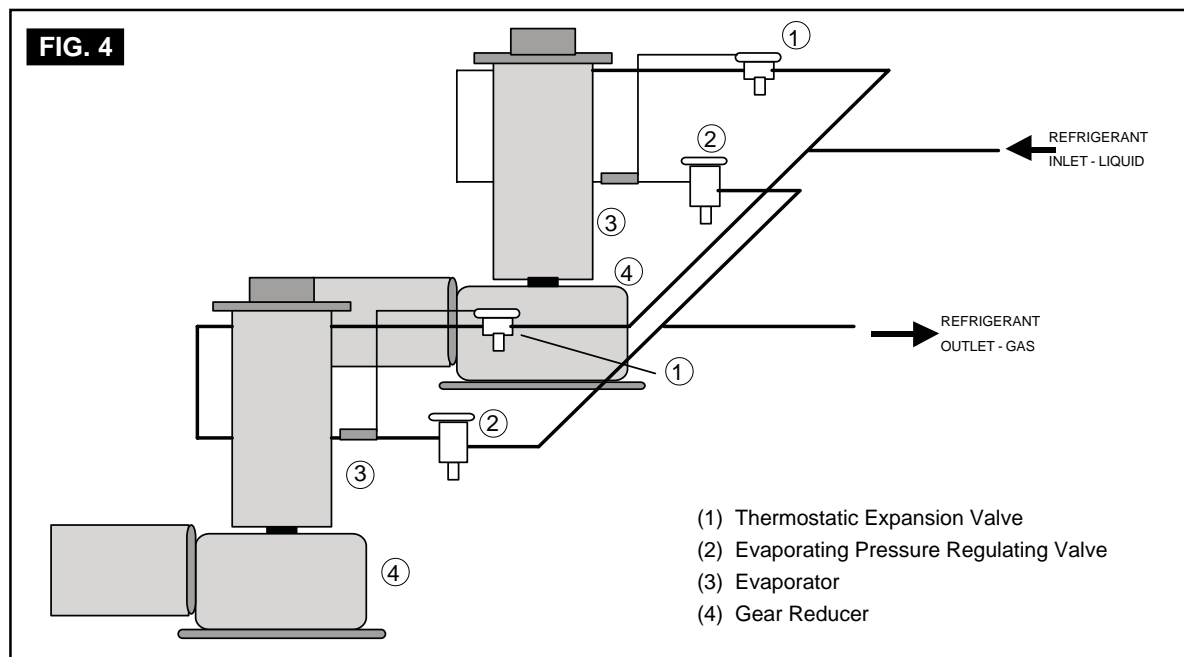
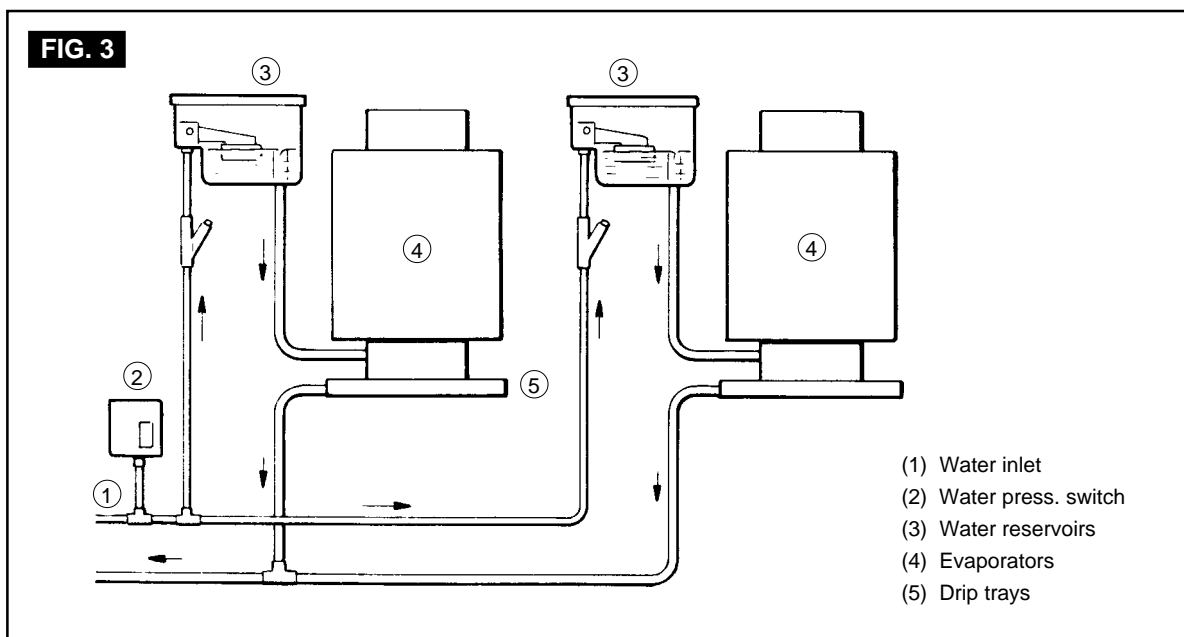

## COMPONENT DESCRIPTION

### REFRIGERATION

#### **Thermostatic Expansion Valve - mod. FLICA TMVX00108 (MOP 3.5 - NOZZLE 4.5)**

The metering device for both the evaporators, the valve senses the temperature of the suction line and vary the amount of liquid refrigerant that passes through the valve into the evaporators, this maintaining a constant level of refrigeration. TXV is normally factory set.

**EPR valve.** Evaporator Pressure Regulator Valve. This valve maintains a constant pressure on evap. inlet regardless of the pressure on the outlet so it keeps the evaporator temperature above a pre-determined value preventing dangerous freeze-up conditions (KVP 22).

#### **Evaporators**

Where the water is frozen into ice crystals. As the slowly turning auger lifts the ice, as it is being made and it forces it up and out of the "BREAKER" or spout where an extra water is compressed out of the ice. The ice then drops through the chute, into the storage bin.

### EVAPORATOR

#### **Evaporator**

A refrigerated vertical tube filled with water and containing a water seal and auger.

#### **Auger**

A stainless steel triple spiral auge, it pushes the ice ribbon up to the top of the evaporator

#### **Water Seal**

A two parts "face" seal, the top half rotating with the auger, the bottom half stationary, the sealing action being where the two seal "faces" meet.

#### **Ice Breaker**

Where the ice is compressed and much of the extra water is squeezed out of it before it reaches the ice spout.

#### **The Thrust Bearing (Top Bearing)**

As the ice is pushed up the evaporator, the auger is thrust down and pressure from the auger thrust is taken up by this bearing.

### AUGER DRIVE

#### **Drive Motor**

Coel mod. H80B4/D Kw 0.55 V220/380 Ph. 3 Hz 50 Amps 3.8/2.3 RPM 1400 thermally protected. Provides power through the speed reducer to turn auger.

#### **Gear Reducer**

Zambello mod. WFA 70/100 Ratio 1/400. High and lo speed gear box are oil lubricated. Oil must be changed every 3,000 hours. Use Syntethic Oil only:

ESSO SPARTAN EP 320

The gear reducer is securely bolted on the chassis base and supports the freezing cylinder as well. On its input shaft there is fitted the driving pulley. A separate output shaft with double keys is fitted in the gear box bore and connected to the auger shaft via aluminium casting coupling.

### ELECTRIC CONTROLS & SAFETY DEVICES

#### CONTROL BOX

##### **Drive motor current limiter (2 PCS)**

It senses the intensity at the drive motor, should this exceed its Amps set point, it cuts-off power for an instant sufficient to trigger the Time Delay Device.

##### **Time delay device (Timer)**

With setting dial from 0 to 10 minutes. It delays the energizing of main contactor in relation to its time setting, preventing short cyclings of system. It is factory set on 5 min. delay so, should power supply fail for an instant or should unit operation be interrupted by any safety control; ice maker will resume operation again after 5 minutes.

##### **Contactor**

The contactor fitted in the control box of the MF 102 is the brain of the system. It has 4 contacts normally open, which close when the coil energizes (coil is at 220V 50 Hz) to supply power to the two drive motors and to the contactor coil of condensing unit.

##### **Timer**

The timer functions in place of the Ice level control. The timer knob has to be turned counterclockwise and can be set at any point of dial that goes from 0 to 24 hours, which will correspond to the system operation time. Timer knob can be positioned on "Continuous" for continuous ice maker function operation or on "STOP" to interrupt system operation.

##### **Warning lights (on unit control box)**

**Center** warning light (green), glows when power is on and ice maker is in operation.

**Right** warning light (green), glows when power is ON and ice maker is not running because is under control of time delay device.

**Left** warning light (red), glows when ice maker is out of operation, on account of water pressure swith trip-out.

## **ICE MAKER**

### **Low water pressure switch**

Functions to discontinue the ice making process whenever incoming water pressure is reduced to below 0.8 bar (11 psi). The switch will automatically restart the icemaking process when the water pressure is increased to 1.2 bar (16 psi).

### **Spout switch**

It is mounted on top of the Ice Spout of both freezers and is actuated by the movement of the spring retained pressure plate.

The spout switch acts as a back-up safety switch, should the thermostatic Control Bulb fail and cause ice to jam-up in the ice spout.

The switch will shut-off the icemaker when actuated.

The spout switch can be manually tested by pressing upward the pressure plate.

### **Ice level control (Bin Thermostat)**

It is an adjustable thermostatic control that cuts off ice making operation when its sensing bulb gets in contact with ice deposited in the storage room. The temperature range dial goes from +10°C to -35°C and its long capillary (3,5 mt) attaching the liquid filled bulb, should be conveniently positioned in the storage room at the desired height by holding it with an appropriate bracket to be fashioned in relation to the location possibilities.

## REMOVAL AND REPLACEMENT PROCEDURE

### WATER RESERVOIR

1. Shut-off the water supply to the icemaker.
2. Remove Service Panel and reservoir cover.
3. To remove float only, pry the mounting flanges apart enough to lift one float pivot pin out of the flange hole and pull float up and out of the reservoir (Fig. 5).
4. To remove reservoir:
  - drain water reservoir and freezer assy, using the drain tube attached to the freezer water inlet and then disconnect water inlet tube at reservoir inlet.
5. Remove drain hose from reservoir.
6. Remove evaporator inlet hose from reservoir.
7. Remove mounting screws from reservoir bracket and remove reservoir from icemaker.
8. Reverse to reassemble.

### BEARING AND BREAKER (Fig. 6)

**NOTE.** Removal of the auger, water seal, bottom bearing retainer must begin at the top of the assembly.

To remove the Breaker and Bearing assy:

**WARNING - Disconnect the electrical power to the icemaker at the building source before proceeding with any repair.**

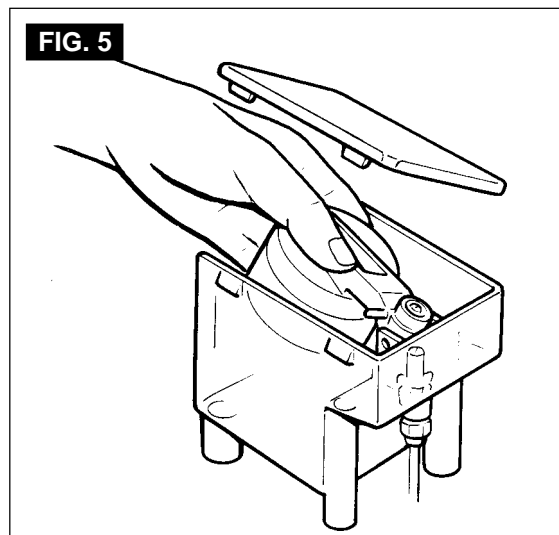

1. Remove panels, disconnect electrical power, shut close water supply and drain water from the water reservoir and freezer assembly by using the drain tube attached to the freezer water inlet.
2. Remove the two screws that secure the spout to the top of the Freezer Assembly.
3. Disconnect wires from micro-box spout switch.
4. remove spout assembly with micro-box.
5. Twist to unloose and remove center plastic cap (A) that is pressed on ice breaker.
6. The breaker may be removed from the auger and evaporator without disturbing the auger.
7. Unscrew center bolt (C) that secures the ice breaker to the auger top.
8. Unscrew 8 screws holding the breaker to the evaporator (two longer screws are used with side bracket of evaporator).
9. Insert two of these screws into two threaded-blind holes, which must have no-bottom on barrel and by evenly drawing them down ice breaker is lifted-up.

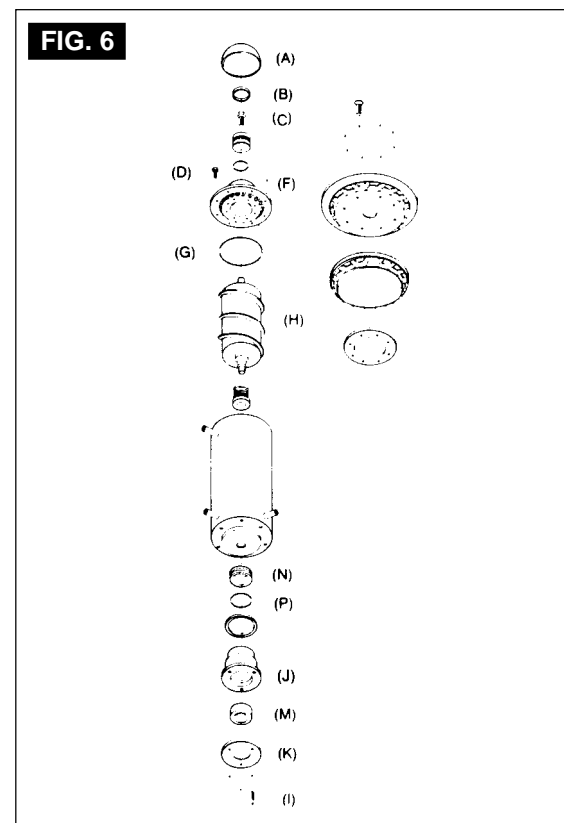

10. Grasp the ice breaker (F) and lift it up entirely. Auger will remain into the freezer worm tube.

11. Service the bearing. Check for rust, rough spots and damages.

A) The bearing is pressed into the breaker, to remote it make use of a rowhide mallet or a piece of wood placed on the bottom side of bearing, tap the bottom of bearing to break it loose and be pulled out of ice breaker.

B) Clean away old grease and replace the "O" Rings (G) in the ice breaker.

C) Replace parts as required. Re-grease bearing with SCOTSMAN part. n. 263612.00 bearing grease.

12. If service inspection is limited to Breaker and Bearing assy, you may now start to reassemble, if instead you have to proceed with removal of other evaporator components follow the next procedure.

### TO REMOVE THE AUGER (Fig. 6)

After having performed the previous procedure you may now progress with:

1. Insert in auger hub threaded hole an eyebolt of 16 mm in order to offer sufficient and positive hook for pulling-out the auger.

2. With the help of an hydraulic hoist, lift up to pull out the auger (H) from freezer barrell. Draw it out evenly respecting the correct vertical axis.

3. Inspect the auger, the critical areas of it are:

A) The auger body. It should be clean and shining. Sometimes an auger will appear clean when wet, but after it is dry it will be seen to be stained. Scrub the auger with ice machine cleaner and hot water.

B) The auger spirals profiles. They should be smooth spotless and perfectly de-burred; if necessary smooth them down by using very fine sand paper.

C) The water seal area. Because the auger has been removed, the water seal will have to be replaced. Remove the water seal top half from the auger and inspect the auger for mineral stains, clean as required.

### TO REMOVE THE WATER SEAL AND BOTTOM BEARING (Fig. 6)

**(Assuming all steps to remove the auger have been performed)**

1. The evaporator will have to be exposed.

2. Unscrews the hex cap screws holding the evaporator to the adaptor of the Gear Reducer assembly.

3. Lift the evaporator up and off the gear reducer assembly, to adequately expose the bottom bearing retainer.

4. Remove the three screws (I) that secure the disc (K) covering the bearing retainer (J). Remove tis disc, insert in the threaded holes in botom bearing retainer two screws of 8 mm and draw them down evenly in order to push out the bottom bearing retainer (J) with seal ring (N).

5. Press out the seal ring (N) and the bearing (M) from the bearing retainer.

6. Inspect the seal ring (N). If reusable, use care to protect it from dirt or foreign matters. If there is any doubt about the effectiveness of the Water Seal, REPLACE IT.

7. Inspect the lower bearing (M) and, it necessary replace it with a new one.

8. To replace the water seal in its housing in bearing retainer, lubricate it with water and push it into its housing.

9. To replace the rotating, part of the water seal that rotates with the auger:

A) Carefully clean the area of the auger where the water seal is to be mounted.

B) Carefully push the water seal on auger bottom shaft.

**IMPORTANT - If the original water seal was leaking, it would be a good idea to inspect the interior of gear reducer.**

### TO REPLACE THE EVAPORATOR

**(Assuming that all steps for removal of the thrust bearing, breaker, auger and bottom bearing and seal retainer have been performed)**

1. Remove most part of refrigerant from icemaker.

2. Shut the hand valves fitted on liquid and suction lines external by the icemaker, then discharge the refrigerant from icemaker system.

3. Unloose the refrigerant flare connections at the thermostatic expansion valve outlet.

4. Disconnect the refrigerant line at the flanged connection at the evaporator outlet.

**NOTE.** All refrigerant openings must be immediately plugged as soon as they are opened.

5. Lift the evaporator up and off the Gear Reducer adaptor.

6. After installing the bearing retainer in the bottom of new evaporator, connect the refrigerant lines at the corresponding fittings.

7. Replace filter drier and evacuate the system until dehydrated, then correct the refrigerant charge. Check for leaks.

8. Install auger, breaker, ice spout in reverse order of disassembly. See "To reassemble Evaporator and Auger".

#### **TO REASSEMBLE THE EVAPORATOR AND AUGER**

1. After the gear reducer and coupling have been inspected, fasten the evaporator to the gear reducer adaptor.

2. Lower the auger into the evaporator barrel, slightly turning it to match up with the coupling. Do not drop into the evaporator.

3. Complete the reassembly by reversing the disassembly for breaker, bearing and spout assembly.

#### **TO REMOVE THE GEAR REDUCER ASSEMBLY**

1. Remove screws and all service panels.

2. Remove screws securing the drive motor on gear box input shaft.

3. Remove four nuts and washers which hold the gear box adaptor to the evaporator assembly.

4. Remove screws securing upper evaporator bracket to left side chassis.

5. Using an Hydraulic Hoist raise the evaporator assembly to facilitate removal of entire gear box.

6. Unloose and remove four nuts holding the gear box to unit base. The gear box is now loose and can be removed. Do not tilt to avoid oil spillage.

7. To remount the Gear Reducer Assembly reverse the removal procedure taking care to position correctly the output shaft with its key well in shape.

**NOTE.** *If there is evidence of water in the oil (rusty bearings, oil level too high), carefully inspect the interior components of gear box. If in doubt about the condition of a part replace it.*

#### **TO REMOVE THE DRIVE MOTOR**

1. Remove service panels.

2. Unloose and remove screws securing the drive motor to the gear reducer.

3. Disconnect wire leads to motor.

4. Withdraw the drive motor from the gear reducer shaft.

5. To replace the Drive Motor Assembly reverse the removal procedure making sure to correctly align the two drive pulleys and give the correct tension to the Drive Belt.

**NOTE.** *When resuming unit operation, make sure that drive motor has been electrically connected to rotate in the correct direction (Auger must turn counterclockwise) otherwise reverse the polarity of its supply line.*

## SERVICE DIAGNOSIS

### NO ICE BEING PRODUCED

#### STATUS: NOTHING OPERATES

- A) Check. Voltage to the unit, restore it if there is none. Compare to the nameplate.
- B) Check. Master switch, switch ON if OFF.
- C) Check. Bin thermostat. If bulb is still surrounded (buried) by ice the cut-out of thermostat is normal, if not, thermostat must be adjusted or replaced.
- D) Check. The spout switch. It opens from excess pressure of ice inside the ice chute: this should only happen when the bin thermostat does not shut-off when reset when the ice melts.
- E) Check. Water supply line. The water pressure switch will reset when water pressure in water supply line raise to reach 1.2 bar.
- F) Check. The drive motor. If will not run we can assume there is no-power to it, so check drive motor relay for reason of relay contact not closing, if, instead, there is power to the drive motor terminals check for motor winding continuity, if interrupted replace drive motor assembly.

### NO ICE BEING PRODUCED

#### STATUS: UNIT OPERATES

- A) Check. Water reservoir. If filled regularly with water, if not look for eventual water restriction at the float valve.

- B) Check. Drive coupling. If worn or split in two pieces, replace it.
- C) Check. Gear reducer, for one gear stripped.
- D) Check. Any other refrigerant control fitted on refrigerant lines externally the icemaker that have eventually shut-off and cutted.
- E) Check. Condensing unit (Remote high side) operation.

### NO OR LITTLE ICE BEING PRODUCED

#### STATUS: UNIT OPERATES INTERMITTENTLY

- A) Check. Drive motor current limiter. If it is the cause of intermittency, in this case check immediately drive motor for:
  - a) Correct rotation
  - b) Rotor shaft is not seized
  - c) Amps pulled are within nameplate rating.
- B) Check. Gear reducer
  - oil level too low
  - water in gear box
  - partially seized, gear pinion worn-out
  - too stiff, gear pinion worn out
 Repair or replace it.
- C) Check. Ice Breaker and Thrust bearing. If broken or worn or seized. Repair or replace them.
- D) Check. For freeze up situation caused by too cold ambient and water condition.
- E) Check. Auger and Freeze barrel. If they are badly scored, must be replaced.

## WIRING DIAGRAM 230-400/50/3+N MF 102 WITH REMOTE CONDENSING UNIT

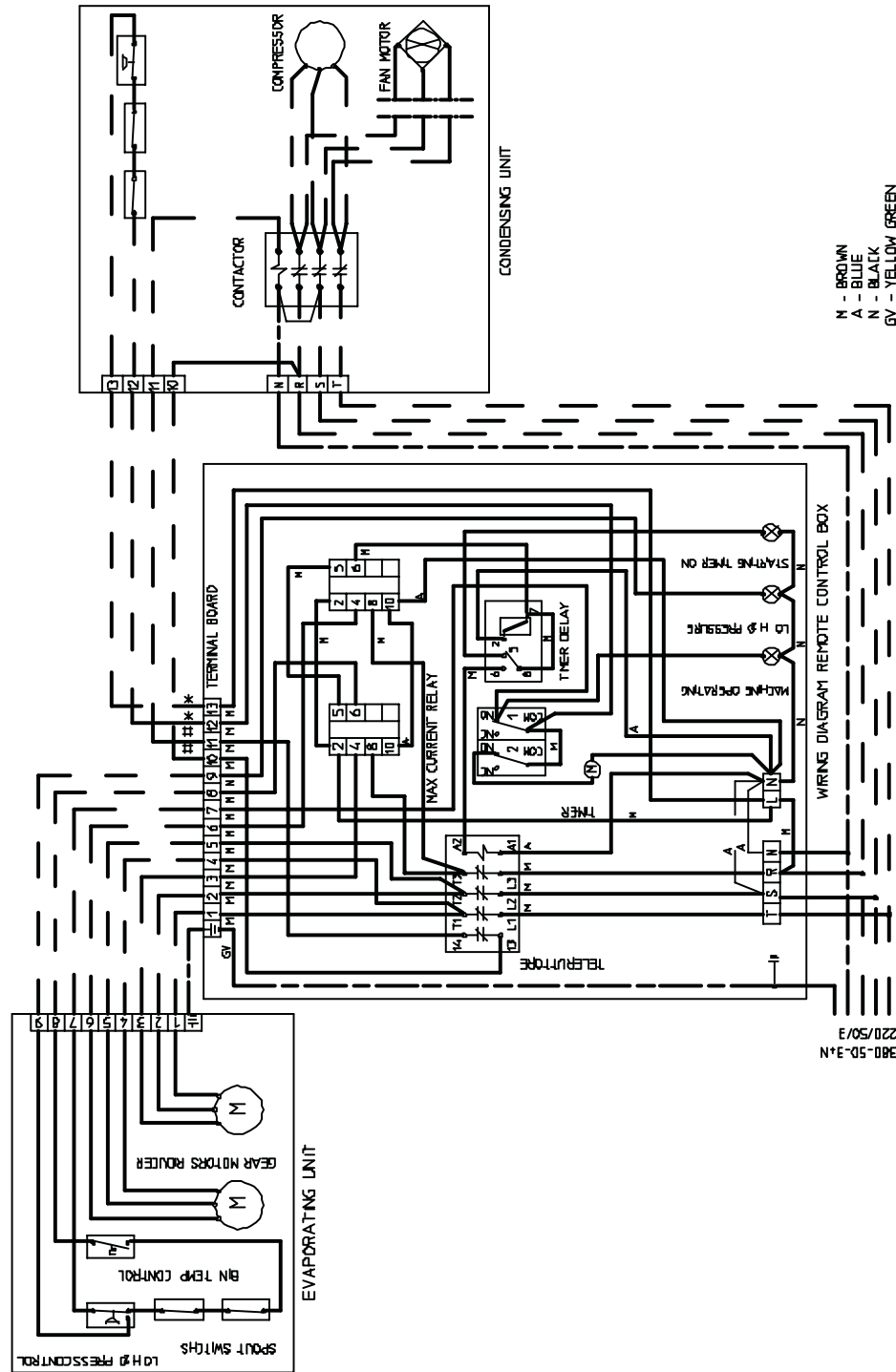

380-50-3+N  
220/50/3

N - BROWN  
A - BLUE  
N - BLACK  
GV - YELLOW GREEN

- ‡ 10-11 - TO COMPRESSOR CONTACTOR COIL
- \* 12-13 - TO CONDENSING UNIT SAFETY CONTROLS
- NOT SUPPLIED WITH THE UNIT JUST FOR MODEL 380/50/3+N
- NOT SUPPLIED WITH THE UNIT JUST FOR MODEL 380/50/3+N
- JUST FOR MODEL 220/50/3
- JUST FOR MODEL 220/50/3

## WIRING DIAGRAM 230-400/50/3+N MF 102 IN MULTIPLE INSTALLATION

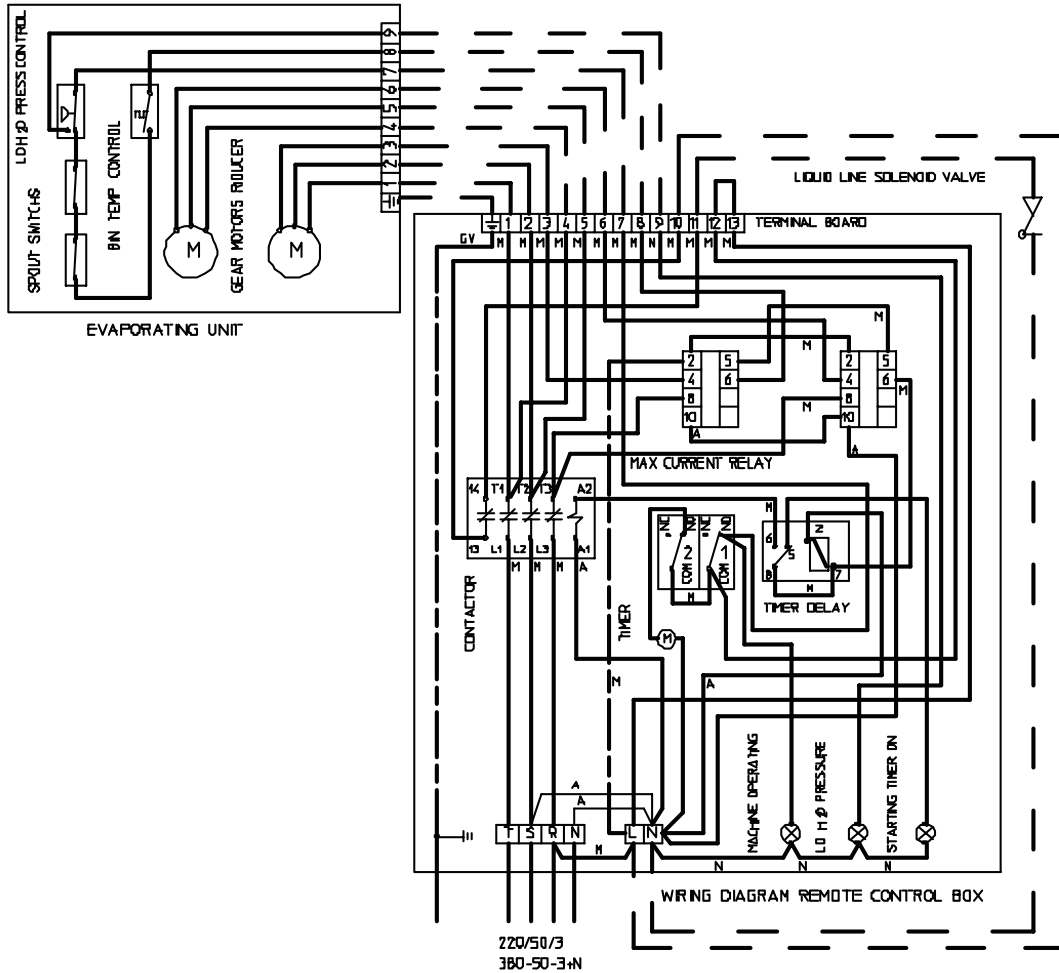

059505-00 MDD003

- N - BROWN
- A - BLUE
- N - BLACK
- GV - YELLOW GREEN

# 10-11 - TO COMPRESSOR CONTACTOR COL  
 \* 12-13 - TO CONDENSING UNIT SEFEY CONTROLS

- NOT SUPPLIED WITH THE UNIT
- NOT SUPPLIED WITH THE UNIT JUST FOR MODEL 380/50/3+N
- JUST FOR MODEL 380/50/3+N
- JUST FOR MODEL 220/50/3

## MAINTENANCE AND CLEANING

A SCOTSMAN ICE SYSTEM represents a sizable investment of time and money in any company's business. In order to receive the best return for that investment, it **MUST** receive periodic maintenance.

It is the USER'S responsibility to see that the icemaker is properly maintained. It is always preferable and less costly in the long run, to avoid possible down time by keeping it clean: adjusting it as needed; and by replacing worn parts before they can cause failure. The following is a list of recommended maintenance that will help keep the machine running with a minimum of problems. Maintenance and Cleaning should be scheduled at a minimum of twice per year.

**WARNING. Electrical power will be ON when doing in place cleaning. Switch it OFF before completing the cleaning procedures.**

### ICE MAKING SYSTEM - In place cleaning

1. Check and clean any water treatment devices, if any are installed.
2. Remove Service Panels.
3. Stop unit operations.
4. Remove ice chutes that convey the ice into storage compartment.
5. Remove the cover to both water reservoir and block the float up.
6. Drain the water reservoir and freezer assembly using the drain tube attached to the freezer water inlet. Return the drain tube to its normal upright position.

**WARNING. SCOTSMAN Ice Machine Cleaner contains Phosphoric and Hydroxyacetic acids. These compounds are corrosive and may cause burns. If swallowed, DO NOT induce vomiting. Give large amounts of water or milk. Call Physician immediately. In case of external contact, flush with water. KEEP OUT OF THE REACH OF CHILDREN.**

7. Prepare cleaning solution: Mix two liters of SCOTSMAN Ice Machine Cleaner with 10 liters warm water per each evaporator.

8. Slowly pour the cleaning solution into each water reservoir until they are both full. Wait 10 minutes, then, put the ice maker in operation, after another 5 minutes of delay the unit will start running.

9. As the icemaker begins to use water from the reservoirs, place under both ice spouts a container to collect in it the slushy ice being now made.

10. Continue to add more cleaning solution to maintains full both water reservoirs until the cleaning solution is finished up.

11. When both water reservoirs get just empty, stop unit operation.

12. Drain both water reservoirs and freezers assemblies as in step 6. Wash and rinse both reservoirs.

13. Remove the block from the floats in the reservoirs and put unit again under power.

14. After 5 minutes of delay the unit will resume operations. Continue icemaking for a least 15 minutes to flush out any cleaning solution. Check ice for acid taste, continue icemaking until ice tasted sweet.

15. Get rid of all the ice made with the cleaning solution.

**WARNING. DO NOT USE any ice produced from the cleaning solution. Be sure that none of it remain available.**

16. Replace ice chutes and service panels.

### ICE MAKING SYSTEM - Maintenance

1. Check setting and function of bin thermostat. Hold ice on control bulb to make sure that shut-off unit operations.

2. Remove service panels and remove covers from both water reservoirs and depress the floats to ensure that full stream of water enters each reservoir.

3. Check drive motor operation: normal operating temperature is about 70 °C which is hot to touch. Check with ammeter amps drawn and make sure they are in the limit of Drive Motor windings.

**WARNINGS - Disconnect electrical power before beginning the following operations.**

4. Check gear box oil level through its sight glass.

Gear box is filled with synthetic oil, which must be replaced every 3,000 working hours.

Use following synthetic oil:

ESSO SPARTAN EP 320

5. Remove chute and ice spout assy to inspect to seal and top bearing seated in the ice breaker, wipe clean of old grease and apply a coating of food grade grease SCOTSMAN P:N 263612.00 or ezuivalent.

6. replace all parts removed and make sure of the correct setting of time delay by putting unit under power. Unit should begin to run after about 5 minutes of delay.

7. With unit in operation check through the liquid sight glass for the proper refrigerant charge situations.

8. Check function of spout switch by manual pressing the spout switch.

9. Re-fit ice chutes and service panels.