

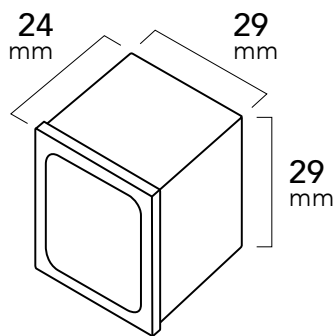

Modular cube

Large

Specific weight 17 g



Dice

Specific weight 10 g

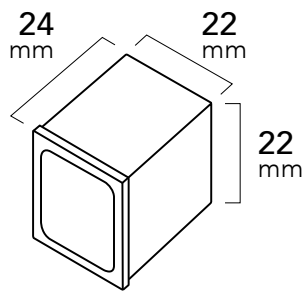

Half-large

Specific weight 6 g

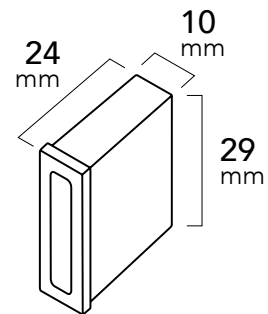

M series



Full modular cubes icemakers range with vertical evaporator and sleek design.

The M Series offers a high productivity with an extreme easiness of use.

Full stainless-steel body, easy to inspect. This icemakers line represents the best solution for all needs of high volumes of ice. They can be matched with the wide choice of Icematic storage bins.

All these features make the M series ideal for fast-food, restaurants with high turnover and those activities needing large volumes of ice in short time.

These icemakers are available with three different ice cube sizes LARGE, DICE e HALF-LARGE.

The range includes also R 290 refrigerating gas machines, increasing efficiency and environmental compliance as 100 % natural and sustainable.

The M Series is the ideal solution for users demanding maximal productivity and great flexibility.



R290 Gas
M195 eco - M205 eco

Eco-friendly versions in R290, 100% natural gas with zero environmental impact.



Rainbow Technology ®
(Optional)

Nano-technological patented treatment that strengthens and protects evaporators from aggressive agents and scaling.



Ozone Kit
(Optional)

For a safe and deep sanitization of your icemaker.

Bar / Restaurant

Hotel

Fast food

Cocktails bar / Disco

M 132

M 192

M 202

M 302



Dimensions

mm

560 x 620 x 575

Dimensions

mm

560 x 620 x 660

Dimensions

mm

760 x 620 x 575

Dimensions

mm

760 x 620 x 575

Production

kg/24h

143 (A)

129 (W)

Production

kg/24h

212 (A)

205 (W)

Production

kg/24h

240 (A)

215 (W)

Production

kg/24h

300 (A)

265 (W)

Bin compatibility

pages 44-45

Bin compatibility

pages 44-45

Bin compatibility

pages 44-45

Bin compatibility

pages 44-45

Standard voltage

220-240 V

1 N / 50 Hz

Standard voltage

220-240 V

1 N / 50 Hz

Standard voltage

220-240 V

1 N / 50 Hz

Standard voltage

220-240 V

1 N / 50 Hz



M 402

M 502

M 195 eco

M 205 eco



Dimensions

mm

760 x 620 x 725

Dimensions

mm

760 x 620 x 725

Dimensions

mm

569 x 620 x 660

Dimensions

mm

760 x 620 x 575

Production

kg/24h

430 (A)

352 (W)

Production

kg/24h

460 (A)

415 (W)

Production

kg/24h

210 (A)

- (W)

Production

kg/24h

220 (A)

- (W)

Bin compatibility

pages 44-45

Bin compatibility

pages 44-45

Bin compatibility

pages 44-45

Bin compatibility

pages 44-45

Standard voltage

220-240 V

1 N / 50 Hz

Standard voltage

220-240 V

1 N / 50 Hz

Standard voltage

220-240 V

1 N / 50 Hz

Standard voltage

220-240 V

1 N / 50 Hz

WORKING WITH AUSTRALIA'S FINEST DEALERSHIPS AND DESIGNERS AND OFFERING THE BEST EQUIPMENT TO SUIT YOUR NEEDS, WE ARE AUSTRALIA'S CHOICE FOR INNOVATIVE FOOD SERVICE EQUIPMENT SOLUTIONS

CUSTOMER SERVICE

Free Call: 1800 222 460 (*Nation wide*)

Phone: (02) 9684 5666

Email: info@scotsice.com.au

SALES

National Accounts

Phone: 0477 071 716

New South Wales Sales

Phone: 0411 089 140

Email: nsw.sales@scotsice.com.au

Queensland Sales

Phone: 0414 817 619

Email: qldsales@scotsice.com.au

Victoria Sales

Phone: 0415 735 273

Email: vicsales@scotsice.com.au

SERVICE & SPARE PARTS

Free Call: 1800 222 460 (*Nation wide*)

Phone: (02) 9684 5666

Email: service@scotsice.com.au

SCOTS ICE AUSTRALIA
foodservice equipment

ABN: 54 080 084 260

Unit 5 / 175-179 James Ruse Drive

Rosehill NSW 2142

www.scotsice.com.au

an Australian Ali Group Partner



The Spirit of Excellence