

CS SERIES



www.scotsice.com.au

SCOTS ICE AUSTRALIA FOODSERVICE EQUIPMENT

Australian Importers and Distributors
of the top leading brands in commercial
kitchen and refrigeration equipment



The spray system produces clear and transparent ice cubes and the patented **Bright Cube** shape grants a longer lasting cube for you to enjoy your cold drinks

Full compact Ice cube with rounded surface for prolonged beverage cooling

Self contained ice cube machines with incorporated large capacity storage bin

Smaller dimensions for easier placement

Modern design and external body entirely in stainless steel

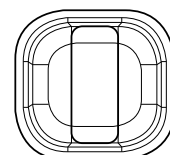
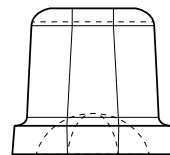

20g
BRIGHT CUBE
32mm x 35mm x 37mm

The **Bright Ice Cube**, appreciated for its versatility, is perfect for use in ice buckets, whiskey on the rocks, cocktails and appetisers. The crystal clear appearance of the Bright Cube makes it essential when a high quality is required.

Hotels ●●●●
Restaurants ●●●○
Fast Food ●●●●

Bars ●●●●
Pubs ●●●●
Nightclubs ●●●●

Spas ●○○○
Fish Markets ●○○○
Super Markets ●○○○

Medical ●●●○
Industry ●○○○

- External body is entirely in stainless steel
- Front controls, accessible and protected
- Easy access for internal cleaning
- Large capacity storage bin



CS20-A

Max. daily production
Up to 20 kg
Max. storage capacity
6.5 kg
Dimensions (mm)
340 W x 480 D x 600/720 H



CS25-A

Max. daily production
Up to 22 kg
Max. storage capacity
7 kg
Dimensions (mm)
400 W x 480 D x 600/720 H



CS35-A

Max. daily production
Up to 35 kg
Max. storage capacity
11.5 kg
Dimensions (mm)
400 W x 540 D x 690/810 H



CS40-A

Max. daily production
Up to 40 kg
Max. storage capacity
15 kg
Dimensions (mm)
500 W x 540 D x 690/810 H



CS50-A

Max. daily production
Up to 50 kg
Max. storage capacity
22 kg
Dimensions (mm)
500 W x 580 D x 800/835 H



CS70-A

Max. daily production
Up to 70 kg
Max. storage capacity
42 kg
Dimensions (mm)
700 W x 580 D x 910/1030 H



CS90-A

Max. daily production
Up to 90 kg
Max. storage capacity
42 kg
Dimensions (mm)
700 W x 580 D x 910/1030 H

Scots Ice Australia
Foodservice Equipment
ABN: 24 353 726 846

Head Office
Unit 5 / 175-179 James Ruse Drive
Rosehill NSW 2142
Free Call: 1800 222 460 (*Nation wide*)
Phone: (02) 9684 5666 | (02) 9637 7099
Fax: (02) 9638 5277 | (02) 9637 7944

Queensland Sales
Phone: 0414 817 619

Victoria Sales
Phone: 0415 735 273

Service and Spare Parts
Unit 5 / 175-179 James Ruse Drive
Rosehill NSW 2142
Free Call: 1800 222 460 (*Nation wide*)
Phone: (02) 9684 5666 | (02) 9637 7099
Fax: (02) 9638 5266

www.scotsice.com.au



www.scotsice.com.au

SCOTS ICE AUSTRALIA
FOODSERVICE EQUIPMENT

Australian Importers and Distributors
of the top leading brands in commercial
kitchen and refrigeration equipment

