

Electric ranges

The 'Novecento Baron' series

Produced in compliance with strict European regulations in terms of safety, hygiene and reliability, the new Novecento baron range is **CE** certified. The innovatory visual design, technology and ergonomics of these appliances are enhanced by the use of AISI 304 18/10 stainless steel with a Scotch Brite finish. Exceptional freedom of configuration makes it possible to combine top-mount models with ovens and neutral bases available with a range of accessories. Configurations can also be customised by placing the appliances perfectly "flush-sealed" either back-to-back or side-by-side, or through "a bridged" arrangement that provides high-level ad-hoc solutions to the requirements of the Chef.



Technical/functional characteristics

The range includes: 2 top-mounted models, 2 unit models with 2, and 4 round hotplates, 2 monobloc models with 4 hotplates over an electric oven.

Specifications:

- cooking surface entirely pressed and cut from a single thick sheet of AISI 304 18/10 steel;
- cast-iron hotplates, seal-mounted to prevent leakage of liquids onto electrical wiring;
- automatic safety thermostat to prevent plates from overheating, especially when empty;
- 7-position ergonomic fitted and inclined knobs for easy regulation;
- "Plate ON" indicator lights";
- various connection possibilities;
- removable instrument panel for perfect access, pressed and shaped to avoid the accumulation of dirt;
- 2" stainless steel feet, height adjustable from 150 to 200 mm.

Electric oven

- Stainless steel heating elements located both overhead and below the oven base plate;
- thermostat temperature control in the chamber from 100°C to 300°C;
- various connection possibilities;
- warning light indicating "Equipment under tension";
- warning light indicating that the set temperature has been reached.



SAFETY, HYGIENE, QUALITY

Technical Data

	9PC/E400	9PC/E800	9PCV/E400 9PCVP/E400	9PCV/E800 9PCVP/E800	9PCF/E800
External dimensions (mm)	400 x 900 x 230	800 x 900 x 230	400 x 900 x 850	800 x 900 x 850	800 x 900 x 850
Cooking top					
Electric plate 4 kW (n°)	2	4	2	4	4
Total plates power (kW)	8	16	8	16	16
Internal oven dimensions (mm)					
Total oven power (kW)	-	-	-	-	6
Total power (kW)	8	16	8	16	22
Power supply tension 50-60 Hz (V)	400V / 3N~	400V / 3N~	400V / 3N~	400V / 3N~	400V / 3N~
Fittings					
Grill GN 2/1 reduced					x
Accessories available upon request					
Front plateshelf		x		x	x
Grill for oven					x
Water stand	x	x	x	x	x
Oven tray					x

For further information on the special features of electric ranges from the **baron** Settecento series, please contact the local dealer.



Installation layouts

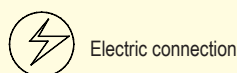
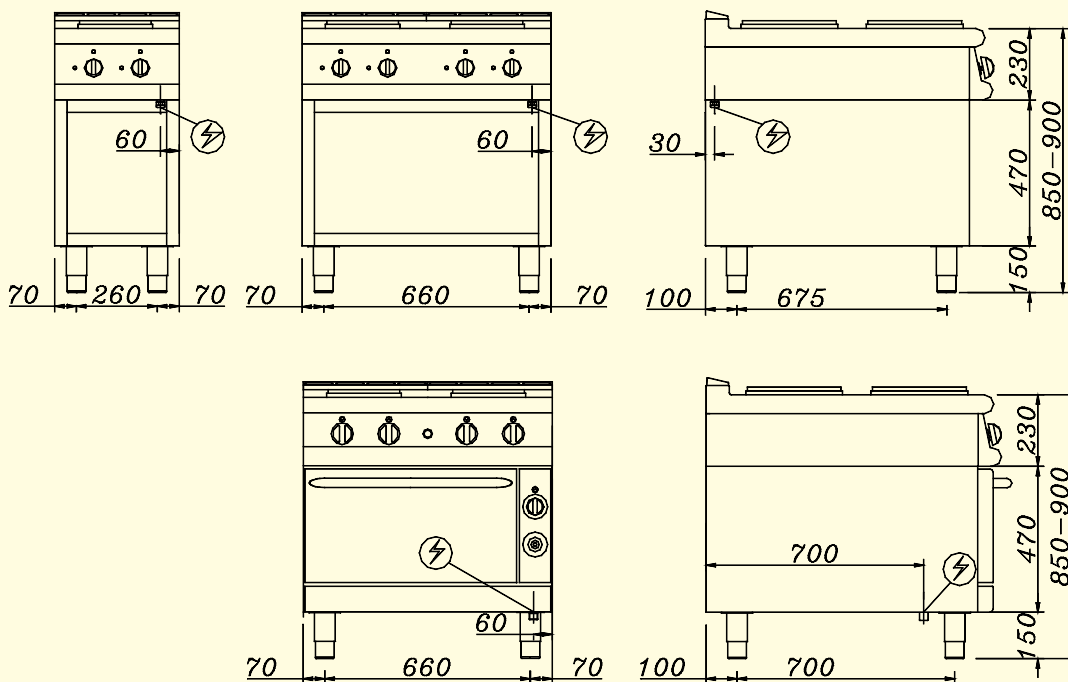

I - 32030 - Bribano di Sedico (BL) Italy - via Miari, 20

Tel. 0437 8554 - Fax 0437 855444

E-mail: info@baronprofessional.com

Website: www.baronprofessional.com