

## Boiling pans

### The 'Novecento Baron' series

Produced in compliance with strict European regulations in terms of safety, hygiene and reliability, the new Novecento baron range is **CE** certified. The innovatory visual design, technology and ergonomics of these appliances are enhanced by the use of AISI 304 18/10 stainless steel with a Scotch Brite finish. Exceptional freedom of configuration makes it possible to combine top-mount models with ovens and neutral bases available with a range of accessories. Configurations can also be customised by placing the appliances perfectly "flush-sealed" either back-to-back or side-by-side, or through "a bridged" arrangement that provides high-level ad-hoc solutions to the requirements of the Chef.



*Balanced internally profiled lid*

*Extended stainless steel handle for safety*



*Large (2") chrome-plated brass drain valve.*



### Caratteristiche tecniche/funzionali

This range includes 2 gas models (one with indirect heating) and an electric model with indirect heating only.

- AISI 304 18/10 stainless steel external coating, container, lid and cavity wall (indirect heat models);
- AISI 316 stainless steel container bottom;
- shelf combined in a single surface with the container;
- lid balanced by an adjustable tension spring system and a heat-resistant handle;
- progressive-action hot and cold water inlet manopole levers knobs ;
- 2" discharge tap

#### Gas models

- Burner set with piezo-electric ignition, pilot burner and thermocouple safety valve;
- pilot burner indicator light;
- the indirect heating models also include a safety assembly (safety valve, depression valve and cavity filler tap).

#### Electric models

- Heating via reinforced Incoloy elements inside the cavity wall, immersed in water and fitted with a protection thermostat;
- progressive power regulation with 'Equipment under tension' indicator light;
- safety assembly, pressure gauge and level indicator as for gas models.

**SAFETY, HYGIENE, QUALITY**

# Technical Data

	MODELLI GAS				MODELLI ELETTRICI	
	9PF/G100	9PF/G150	9PF/G100	9PF/G150	9PF/E100	9PF/E150
Heating	DIRECT	DIRECT	INDIRECT	INDIRECT	INDIRECT	INDIRECT
External dimensions (mm)	800 x 900 x 850	800 x 900 x 850	800 x 900 x 850	800 x 900 x 850	800 x 900 x 850	800 x 900 x 850
Dimensions of basin (diameter)	ø 600	ø 600	ø 600	ø 600	ø 600	ø 600
Rated / real capacity (l)	110	150	110	150	110	150
Total power (kW)	21	21	21	21	16	16
Power supply tension 50-60 Hz (V)					400V/3N~	400V/3N~

Note: gas models are fitted with natural gas nozzles as standard. These can be replaced with the specific nozzles provided for use with LPG.  
For further information on the special features of boiling pans from the **baron** Novecento series, please contact the local dealer.



## Installation layout

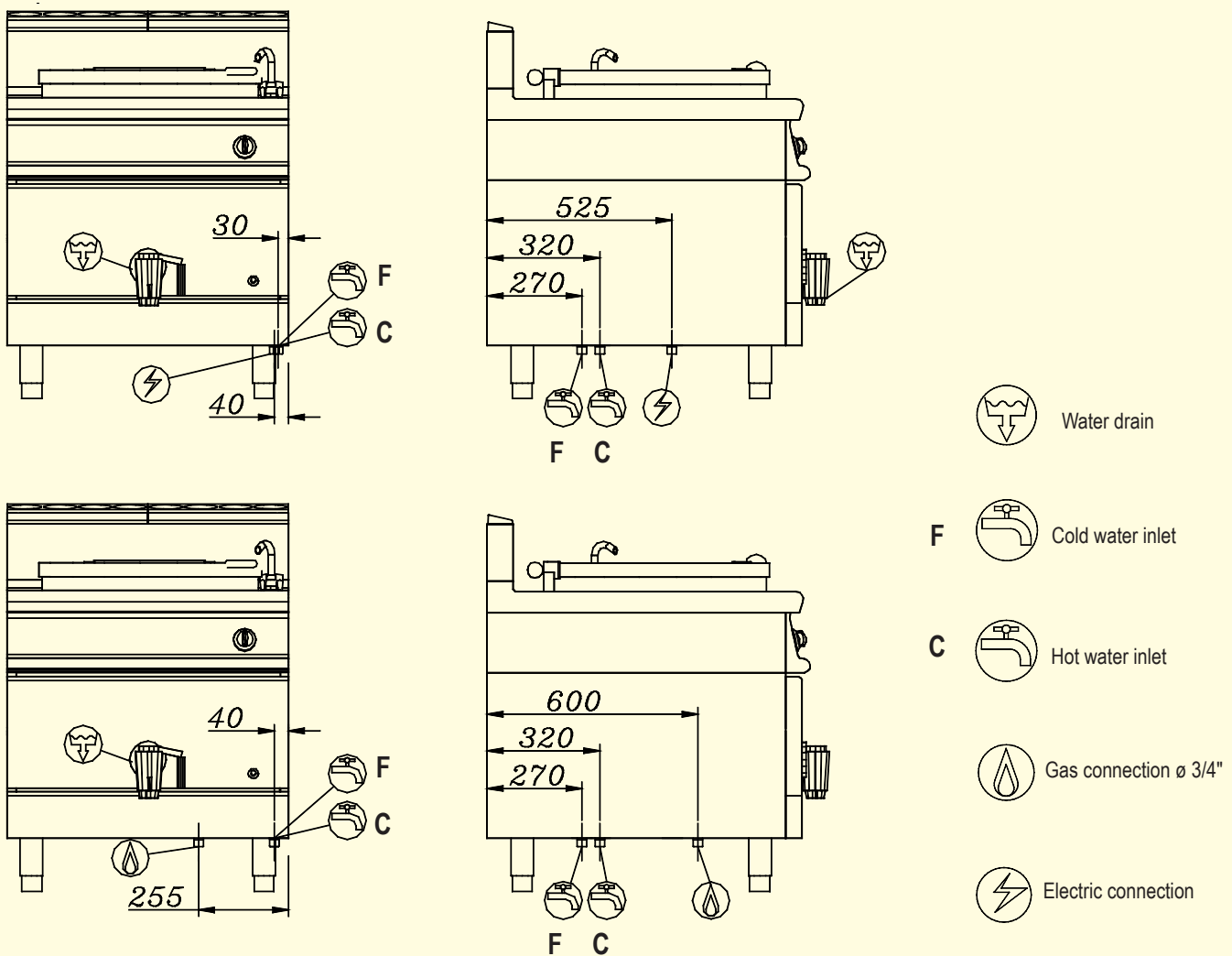

I - 32030 - Bribano di Sedico (BL) Italy - via Miari, 20

Tel. 0437 8554 - Fax 0437 855444

E-mail: [info@baronprofessional.com](mailto:info@baronprofessional.com)

Website: [www.baronprofessional.com](http://www.baronprofessional.com)