

Bain-marie

The 'Novecento Baron' series

Produced in compliance with strict European regulations in terms of safety, hygiene and reliability, the new Novecento baron range is **CE** certified. The innovatory visual design, technology and ergonomics of these appliances are enhanced by the use of AISI 304 18/10 stainless steel with a Scotch Brite finish. Exceptional freedom of configuration makes it possible to combine top-mount models with ovens and neutral bases available with a range of accessories. Configurations can also be customised by placing the appliances perfectly "flush-sealed" either back-to-back or side-by-side, or through "a bridged" arrangement that provides high-level ad-hoc solutions to the requirements of the Chef.



Technical/functional characteristics

This range includes 6 models: 2 top, 2 on unit and 2 on unit with door.

- Cooking surface entirely pressed and cut from a single thick sheet of AISI 304 18/10 steel;
- 18/10 stainless steel reinforced elements positioned outside of the basin
- Thermostat temperature control in the basin of between 30°C and 90°C
- "Equipment under tension" warning light
- Warning light indicating that the set temperature has been reached

- Control knob power released with progressive rotation
- Switch for filling basin
- Various connection possibilities
- Ergonomic fitted and inclined knobs
- Removable instrument panel for perfect access, pressed and shaped to avoid the accumulation of dirt
- Stainless steel basin with rounded edges and overflow unit, suitable for holding small Gastronom 1/1 containers and relative sub-

multiple

- Safety thermostat to prevent overheating of the basin.

SAFETY, HYGIENE, QUALITY

Technical Data

	9BM/E410	9BM/E800	9BMV/E410 - 9BMVP/E410	9BMV/E810 - 9BMVP/E810
External dimensions	400 x 900 x 230	800 x 900 x 230	400 x 900 x 850	800 x 900 x 230
Dimensions of the basin	340 x 630 x 160	720 x 630 x 160	340 x 630 x 160	720 x 630 x 160
Total power (kW)	3,6	6,8	3,6	6,8
Power supply tension 50-60 Hz (V)	230 / 1N	400 / 3N	230 / 1N	400 / 3N
Fittings	Perforated false bottom			
Accessories available upon request				
Mini basin + lid GN1/1				
Mini basin + lid GN1/3				
False bottom 400				
False bottom 800				

For further information on the special features of Bain-marie from the **baron** Novecento series, please contact the local dealer.



Installation layouts

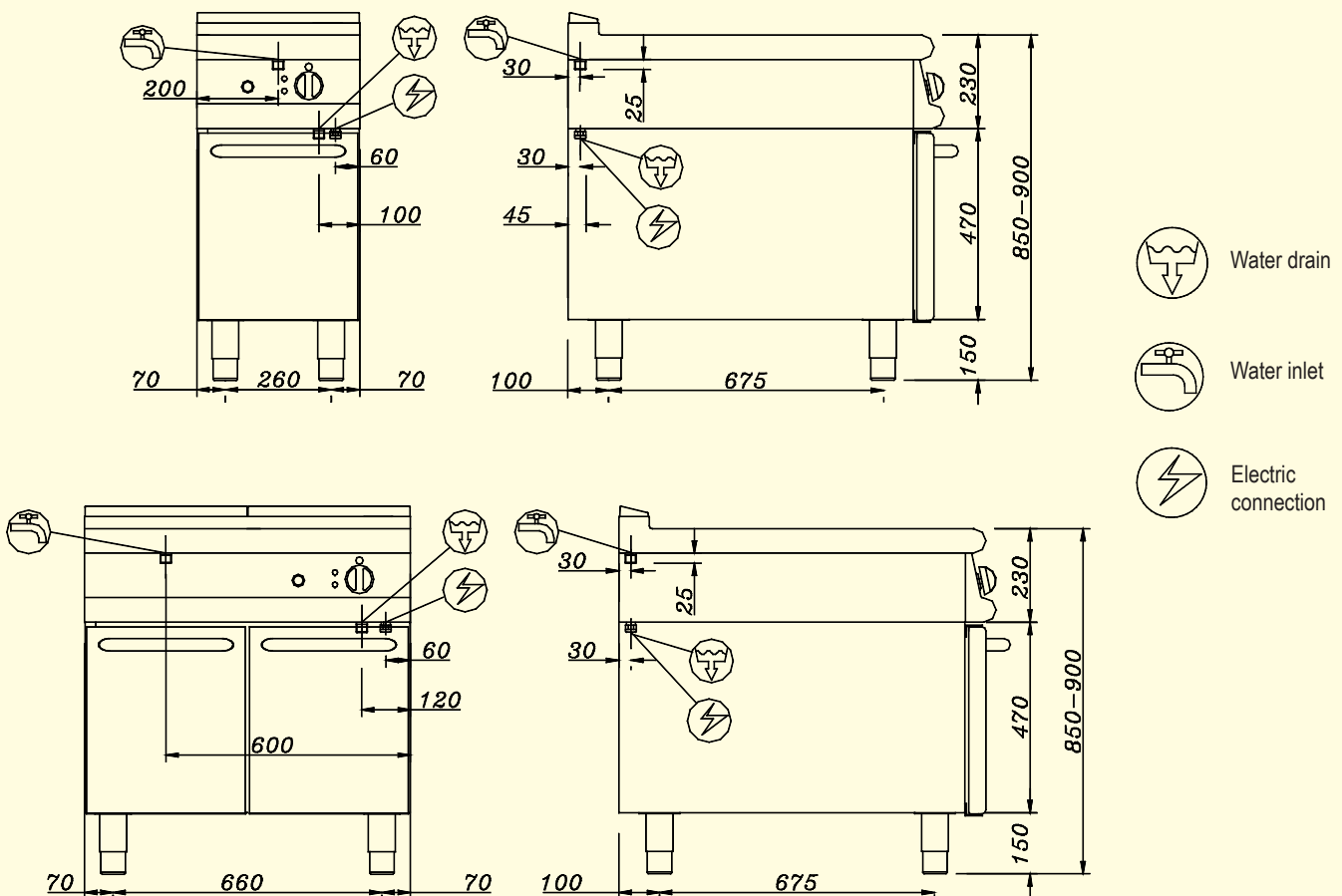

I - 32030 - Bribano di Sedico (BL) Italy - via Miari, 20

Tel. 0437 8554 - Fax 0437 855444

E-mail: info@baronprofessional.com

Website: www.baronprofessional.com