

Bratt pans

The 'Settecento Baron' series

Exceptional levels of reliability, hygiene and safety, all compliant with the strictest European regulations. Modern technology combined with the strength of AISI 304 18/10 stainless steel, with a Scotch Brite finish. Sober and elegant lines are the result of aesthetic research focusing on modern criteria in terms of ergonomics and functionality. This is the 'Settecento Baron' series: a professional kitchen, just 70 centimetres deep, that can be manufactured according to your exact requirements, without making any sacrifices and without any limits in terms of its composition. All of this plus the **CE** mark. Equipment designed and built to guarantee total safety as well as perfect hygiene with the utmost in energy efficiency.

Gas models

- Multi-arm burners with stabilized flame;
- temperature regulation from 120° to 300 °C ;
- piezo-electric ignition;
- safety valve with thermocouple.

Electric models

- Heating by means of armured Incoloy stainless steel heating elements;
- temperature regulation from 120° to 300 °C;
- safety thermostat.



Fixed bratt pans

Available in an electric version only, power supply 400V / 3-phase + neutral, fixed tank with food / sauce outlet for complete discharge and thorough cleaning assisted by internal rounded edges.

Technical/functional characteristics

The range includes 4 different models: stainless steel or compound basin, either gas-powered or electric. The brazier is extremely versatile, suitable for cooking meat, sauces, risottos, omelettes, eggs and vegetables. Specifications:

- removable instrument panel for easy access, pressed and shaped to avoid the accumulation of dirty;
- ergonomic fitted and inclined knobs;
- various connection possibilities;
- basins with rounded edges, stainless steel (8mm thick) or compound bottoms made from 12mm thick steel with high thermal conductivity and 2mm stainless steel internal lining to provide optimal assurance of hygiene and rust prevention of the surface in contact with food;

- 2mm thick basin walls;
- progressive, precise manual movement of the basin;
- basin water filler tap;
- thermostat temperature control;
- balanced lid internally shaped to allow condensation to drop back into the basin.

SAFETY, HYGIENE, QUALITY



Fixed bratt pan

Available in 2 electric models, one 400 and one 800 mm wide, the "multi-cooking" braziers feature a fixed basin with a thick compound bottom. Suitable for optimal cooking of various kinds of foods, these new appliances are ideal for small kitchens.

Specifications:

- 15 litre basin on 400 mm models, 30 litre basin on 800 mm models;
- compound basin with food / sauce outlet with plug and collection bowl in the lower compartment;
- stainless steel structure with height adjustable feet;
- thermostat temperature control.

Technical datas

	7BR/G100	7BR/G105	7BR/E100	7BR/E105	7BRF/E405	7BRF/E805
Pan material	SS	COMPOUND	SS	COMPOUND	COMPOUND	COMPOUND
Esternal dimansions (mm)	1000 x 700 x 850	1000 x 700 x 850	1000 x 700 x 850	1000 x 700 x 850	400 x 700 x 850	800 x 700 x 850
Pan dimansions (mm)	730x400x200	730x400x200	730x400x200	730x400x200	306x510x109	
Rated / real capacity (l)	60 / 45	60 / 45	60 / 45	60 / 45	15	30
Total power (kW)	14	14	7,2	7,2	4,5	9
Power supply tension 50-60 Hz (V)			400/3N~	400V/3N~	400/3N~	400/3N~
Accessories available upon request						
Chute rear upstand						

Note: gas models are fitted with natural gas nozzles as standard. These can be replaced with the specific nozzles provided for use with LPG.
For further information on the special features of Bratt pans from the **baron** Settecento series, please contact the local dealer.



Installation layouts

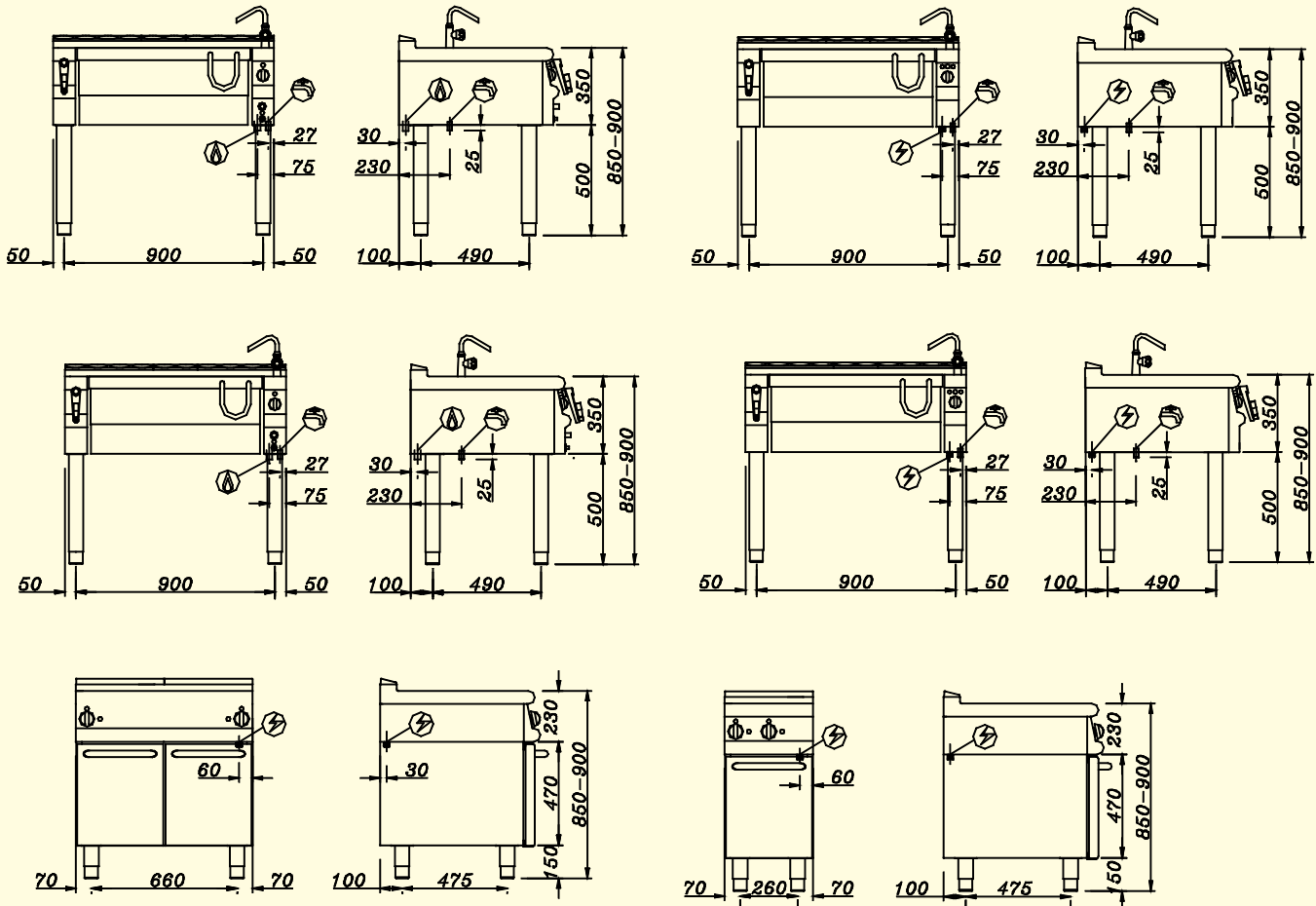

Water drain



Water inlet



Electric connection



Gas connection



I - 32030 - Bribano di Sedico (BL) Italy - via Miari, 20

Tel. 0437 8554 - Fax 0437 855444

E-mail: info@baronprofessional.com

Website: www.baronprofessional.com