



**SERVICE MANUAL**

**MC 1210**  
**R 404 A VERSION**

**Electronic  
modular cubers**



**SPECIFICATIONS**

**ELECTRONIC CUBER MODEL MC 1210 - R 404**

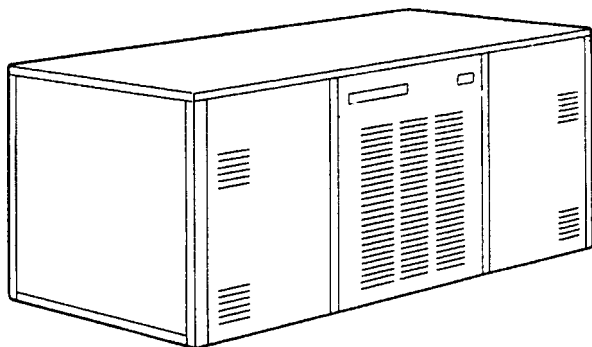

Important operating requirements:

	MIN.	MAX.
Air temperature	10°C (50°F)	40°C (100°F)
Water temperature	5°C (40°C)	40°C (100°F)
Water pressure	1 bar (14 psi)	5 bars (70 psi)
Electr. voltage variations from voltage rating specified on nameplate	-10%	+6%

**ice making capacity**

**AIR COOLED MODELS**

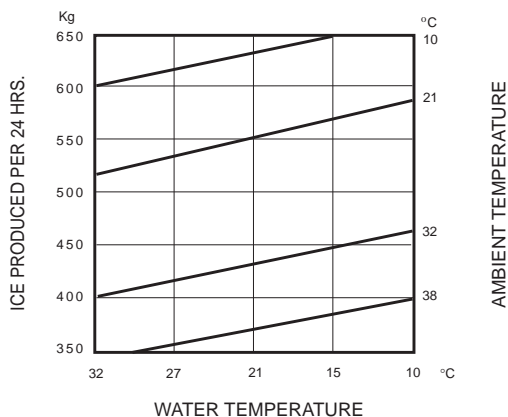

**WATER COOLED MODELS**

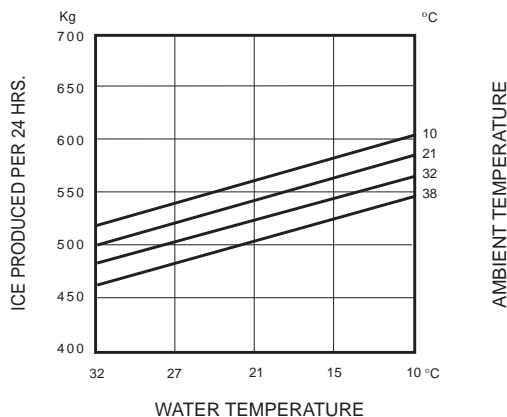

**NOTE.** The daily ice-making capacity is directly related to the condenser air inlet temperature, water temperature and age of the machine.  
 To keep your **SCOTSMAN MODULAR CUBER** at peak performance levels, periodic maintenance checks must be carried out as indicated on page 35 of this manual.  
 Production charts shown are indicating the production of MCM models. For MCS models ice production is approx. 10% lower while for MCL models ice production is approx. 5% lower.

**SPECIFICATIONS**

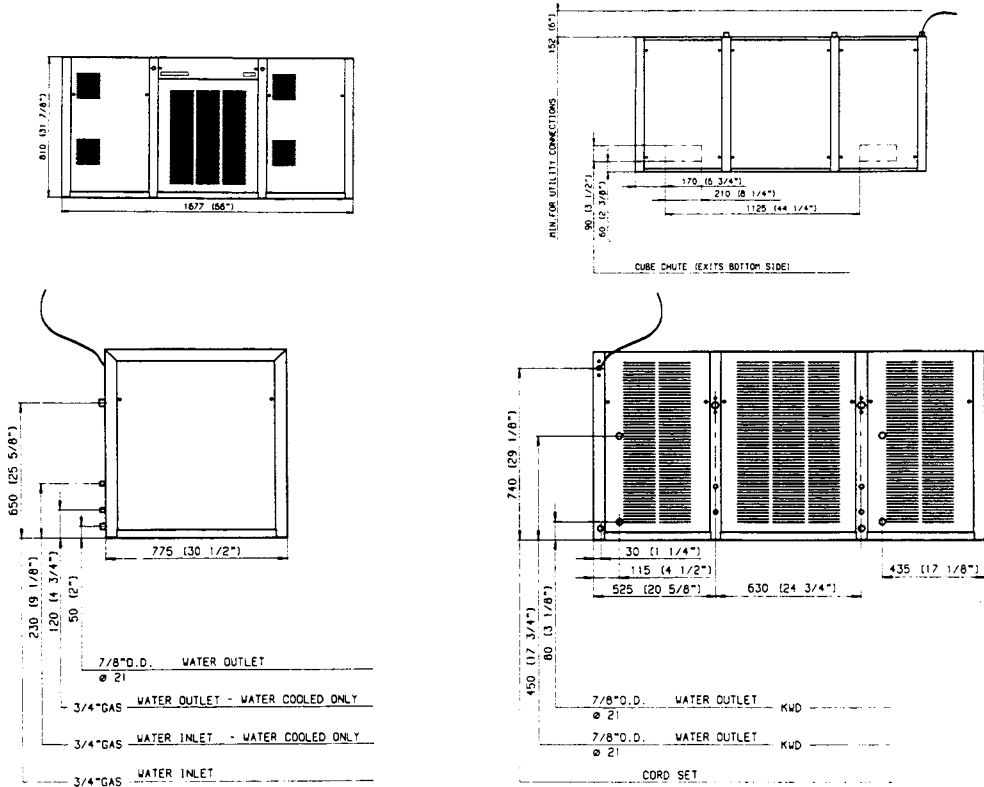

**ACCESSORIES**

KSC 1210: Cube stacking kit

**DIMENSIONS:**

HEIGHT 810 mm.  
 WIDTH 1677 mm.  
 DEPTH 775 mm.  
 WEIGHT Kgs.

**MC 1210 - MACHINE SPECIFICATIONS**

Model	Cond. unit	Finish	Comp. HP	Water req. - lt/24 HR
MC 1210 AS MC 1210 WS	Air Water	Stainless steel Stainless steel	2 x 2.5	1240 6000*

Model	Basic electr.	Amps	Start amps.	Watts	Electric power cons. Kwh x 24 HR	N. of wires	Amps. fuse
MC 1210 AS MC 1210 WS	400/50/3+N	11	28	4800	105	5 x 2.5 m/m <sup>2</sup>	16

Cubes per harvest: MCL 288 large - MCM 408 medium - MCS 792 small  
 \* With water at 15°C

## GENERAL INFORMATION AND INSTALLATION

### A. INTRODUCTION

This manual provides the specifications and the step-by-step procedures for the installation, start-up and operation, maintenance and cleaning for the **SCOTSMAN MODULAR CUBER MC 1210**. The Electronic Modular Cubers of the MC 1210 series are quality designed, engineered and manufactured.

Their ice making systems are thoroughly tested providing the utmost in flexibility to fit the needs of a particular user.

This product qualifies for the following listings:



These icemakers have been engineered to our own rigid safety and performance standards. The VDE - SEV - WRC seals signify that they are listed with them and that they comply with the materials and manufacturing standard of them. These seals also signify that these icemaker models have been inspected and tested by VDE - SEV - WRC inspectors who reserve the right to periodically examine production icemakers at the factory to assure continued compliance.

**NOTE.** To retain the safety and performance built into this icemaker, it is important that installation and maintenance be conducted in the manner outlined in this manual.

#### Storage Bin

Since the MC 1210 Modular Cubers do not have their own attached ice storage bin, it is necessary to use the **Bin B 120**.

### B. UNPACKING AND INSPECTION

#### Modular Cuber

1. Call your authorized SCOTSMAN Distributor or Dealer for proper installation.
2. Visually inspect the exterior of the packing and skid. Any severe damage noted should be reported to the delivering carrier and a concealed damage claim form filled in subject to inspection of the contents with the carrier's representative present.

3. a) Cut and remove the plastic strip securing the carton box to the skid.  
b) Remove the packing nails securing the carton box to the skid.  
c) Cut open the top of the carton and remove the polystyrene protection sheet.  
d) Pull out the polystyrene posts from the corners and then remove the carton.
4. Remove top and sides panels of the unit and inspect for any concealed damage. Notify carrier of your claim for the concealed damage as stated in step 2 above.
5. Remove all internal support packing and masking tape and the hardware package.
6. Check that refrigerant lines do not rub against or touch other lines or surfaces, and that the fan blade moves freely.
7. Check that the compressor fits snugly onto all its mounting pads.
8. See data plate on the rear side of the unit and check that local main voltage corresponds with the voltage specified on it.

**CAUTION.** Incorrect voltage supplied to the icemaker will void your parts replacement program.

9. Remove the manufacturer's registration card from the inside of the User Manual and fill-in all parts including: Model and Serial Number taken from the data plate. Forward the completed self-addressed registration card to Frimont factory.

#### Storage bin - B 120

1. Follow the steps 1, 2 and 3 above to unpack the storage bin.
2. Carefully lay it down on its rear side and fit the four legs into their sockets.
3. Remove all internal support packing and masking tape as well as the plastic ice cube deflector.
5. Remove the manufacturer's registration card from the inside of the User Manual and fill-in all parts including: Model and Serial Number taken from the data plate. Forward the completed self-addressed registration card to Frimont/ factory.

### C. LOCATION AND LEVELLING

**WARNING. This Ice Cuber is designed for indoor installation only. Extended periods of operation at temperature exceeding the following limitations will constitute misuse under the terms of the SCOTSMAN Manufacturer's Limited Warranty resulting in LOSS of warranty coverage.**

1. Position the Bin in the selected permanent location.

Criteria for selection of location include:

a) Minimum room temperature 10°C (50°F) and maximum room temperature 40°C (100°F).

b) Water inlet temperatures: minimum 5°C (40°F) and maximum 40°C (100°F).

c) Well ventilated location for air cooled models. Clean the air cooled condenser at frequent intervals.

d) Service access: adequate space must be left for all service connections through the rear of the ice maker. A minimum clearance of 15 cm (6") must be left at the sides of the unit for routing cooling air drawn into and exhausted out of the compartment to maintain proper condensing operation of air cooled models.

2. Level the Storage Bin Assy in both the left to right and front to rear directions by means of the adjustable legs.

3. Inspect the Storage Bin top mounting gasket which should be flat with no wrinkles, to provide a good sealing when the Modular Cuber is installed on top of it.

4. Place the Modular Cuber on top of Storage bin using care not to wrinkle or tear the gasket.

5. Lift a little bit the Modular Cuber right side in order to be able to mount, in one of the two ice chute openings, the ice level control bracket.

6. Remove the PVC plastic plug closing the round hole located beside the ice chute opening.

7. Trace the ice level control assy, secured for the transport on top of the evaporator of the Modular Cuber, and direct it down through the unplugged round hole into the Storage Bin.

8. Secure the ice level control assy on its bracket by means of the two screws found in the hardware package supplied with the unit.

9. Make a cut (shear) in the PVC plastic plug that goes from its edge to the center; insert the ice level control cable in the center of the plastic plug so to prevent it from any sort of contact with the unit frame, then place again the PVC plug in the round hole keeping the cable exceeding portion inside the unit.

10. Install the two plastic ice cube deflector by hooking them on the flange of the ice chute openings in unit base (see illustration).

### D. STACKING INSTALLATION

A Stacking Kit KSC 1210 is available as an accessory on request to allow the installation of two Modular Cubers one on top of the other.

The Stacking Kit is consisting of:

- a) two plastic reinforced Ice Chute Connections
- b) two Interface P.C. Boards
- c) two Extension Cables

enabling to cover any stacking installation combination as:

a) When stacking an Electronic Modular Cuber on an Electromechanical type (Earlier series).

b) When stacking two Electronic Modular Cubers.

c) When stacking two different Electronic Modular Cubers (twin P.C. Boards version with the previous single one).

### Mixed units installation

1. Unloose the screws and remove the top panels.

2. Trace and remove from the top of the evaporators of Electronic Cuber the metal brackets to be used to secure the ice level controls inside the storage bin.

3. Lift a little bit the Modular Cuber front side in order to be able to mount the ice level control bracket .

4. Put the Electronic Modular Cuber on top of the Electromechanical unit.

5. Remove the ice chutes from both the units and insert, through the ice discharge openings of the upper unit, the plastic reinforced Ice Chute Connections.

6. Disconnect the ice level control terminal plug from the P.C. BOARDS of Electronic Modular Cuber.

7. Install and secure the ice level controls on their brackets by means of the two screws supplied with the unit.

8. Direct each ice level control cable first to pass through the ice discharge opening of the

bottom machine with the protective sheath correctly located in correspondance of this opening and then to pass through the round hole provided into the base of the Electronic Modular Cuber (Upper unit).

9. Connect the electric plug of the ice level control cable to the Cable Extension, then plug-in this one into its P.C. BOARD socket.

10. Rotate clockwise the TRIMMER setting screw located in the front of P.C. BOARD, to its maximum power, so to compensate the greater resistance caused by the Cable Extension addition.

**NOTE.** Replace the existing ice deflector/bulb holder combination with the new longer one, part number 660498 01, to prevent the light beam of the Ice Level Control from interfering with it.

11. Stick, with accuracy, the rubber stripe onto the upper edge of the front panel of the lower unit in order to fill the air gap between the two machines.

12. Place again in their position the two ice chutes and finally re-fit all the service panels previously removed.

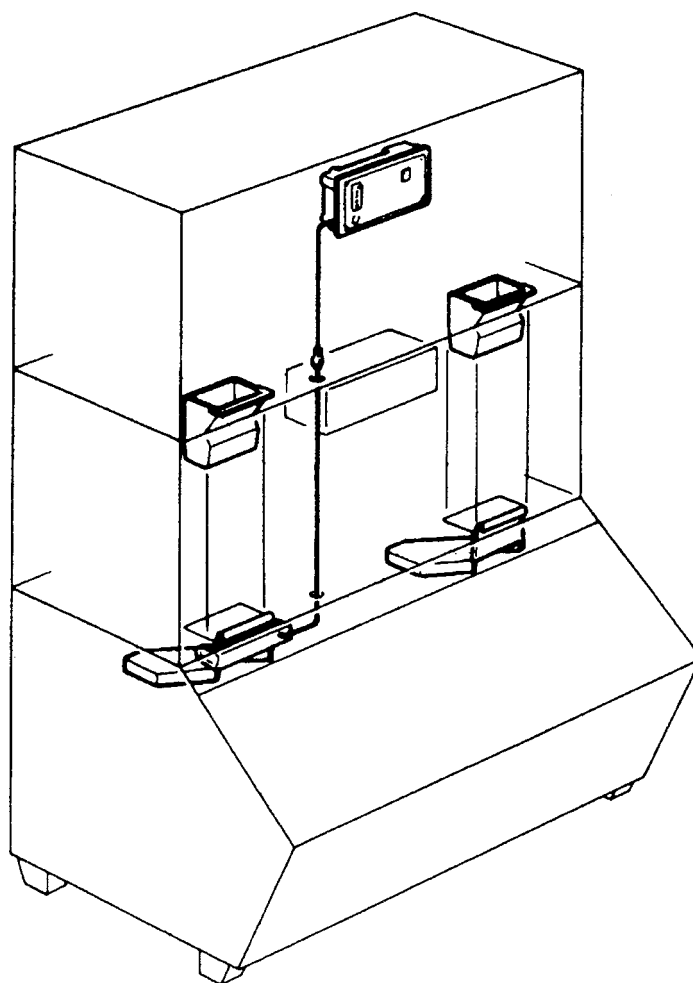

### Electronic units installation

1. Unloose the screws and remove the top panels.
2. Put the second Electronic Modular Cuber onto the bottom one and align the two cabinets correctly.
3. Remove the ice chutes from both the systems 1 of the units and insert, through the ice discharge openings of the upper unit, the plastic reinforced Ice Chute Connections.
4. Disconnect the ice level control terminal plug from the P.C. Board of the upper Electronic Modular Cuber (now called **unit 2**).

**ATTENTION. The P.C. Boards to be connected to the interface must be of the same supplier.  
If not the machines do not work and stop at BIN FULL LED.**

5. Secure the two interface P.C. Board to the contactor metal bracket of the lower unit (now called **unit 1**) by means of the supplied plastic clamp.
6. Disconnect the ice level control terminal plug from the P.C. Board of the unit 1 and connected it to the INLET socket of the Interface P.C. Board (shorter wire).

7. Connect the **primary OUTLET** terminal plug of the Interface P.C. Board (wire of medium length) to the P.C. Board socket of the **unit 1**.
8. Connect the **secondary OUTLET** plug (longer wire) of the interface P.C. Board to the P.C. Board socket of the **unit 2** (see drawing).
9. Turn clockwise (to its max. power) the TRIMMER setting screw (located on the front center of P.C. Board) of the ice level control of the **unit 2**

**NOTE. Repeat steps from 3 to 9 for the Systems 2 of the units.**

10. The interface P.C. Board is now ready to stop simultaneously the operation of the two units when the infrared beam of the ice level control is interrupted by the stored ice cubes.

**ATTENTION. After removal of the ice cubes to re-establish the infrared beam both units resume their operation starting from the beginning of freezing cycle.  
During the first freezing cycle it could be possible that the ice cubes produced by one of the two ice makers be not of the correct shape (cloudy and shallow) due to an insufficient water level in its sump tank. This minor problem will disappear in the next batch because in the coming harvest cycle the sump tank will be properly filled-up.**

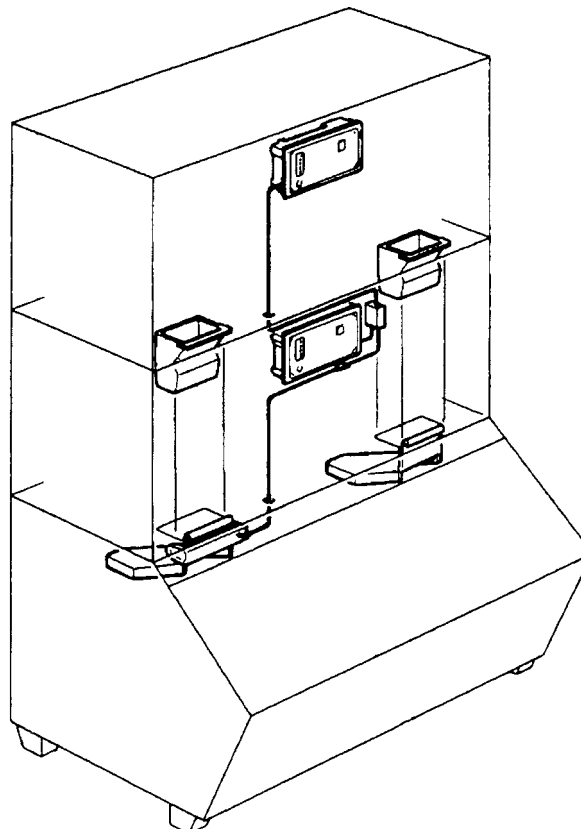

11. Stick, with accuracy, the rubber stripe onto the upper edge of the front panel of the lower unit in order to fill the air gap between the two machines.

12. Place again in their position the two ice chutes and finally re-fit the service panels previously removed.

#### D. ELECTRICAL CONNECTIONS

See data plate for current requirements to determine wire size to be used for electrical connections. All SCOTSMAN icemakers require a solid earth wire.

All SCOTSMAN ice machines are supplied from the factory completely pre-wired and require only electrical power connections to the wire cord provided at the rear of the unit.

Make sure that the ice machine is connected to its own circuit and individually fused (see data plate for fuse size).

The maximum allowable voltage variation should not exceed -10% and +6% of the data plate rating. Low voltage can cause faulty functioning and may be responsible for serious damage to the overload switch and motor windings.

**NOTE.** All external wiring should conform to national, state and local standards and regulations.

Check voltage on the line and the ice maker's data plate before connecting the unit.

#### E. WATER SUPPLY AND DRAIN CONNECTIONS

##### General

When choosing the water supply for the ice cuber consideration should be give to:

- a) Length of run
- b) Water clarity and purity
- c) Adequate water supply pressure

Since water is the most important single ingredient in producing ice you cannot emphasize too much the three items listed above.

Low water pressure, below 1 bar may cause malfunction of the ice maker unit.

Water containing excessive minerals will tend to produce cloudy coloured ice cubes, plus scale build-up on parts of the water system.

##### Water supply

Connect the 3/4" GAS male fitting of the solenoid water inlet valve, using an approved food grade flexible tube or a 3/8" O.D. copper pipe, to the cold water supply line with regular plumbing fitting and a shut-off valve installed in an accessible position between the water supply line and the unit.

If water contains a high level of impurities, it is advisable to consider the installation of an appropriate water filter or conditioner.

#### Water supply - Water cooled models

The water cooled versions of SCOTSMAN Ice Makers require two separate inlet water supplies, one for the water sprayed for making the ice cubes and the other for the water cooled condenser.

Connect the 3/4" GAS male fitting of the water inlet, using flexible tubing or a 3/8" O.D. copper pipe, to the cold water supply line with regular plumbing fitting and a shut-off valve installed in an accessible position between the water supply line and the unit.

#### Water drain

The recommended drain tube is a plastic or flexible tube with 18 mm (3/4") I.D. which runs to an open trapped and vented drain. When the drain is a long run, allow 3 cm pitch per meter (1/4" pitch per foot).

A vent at the unit drain connection is also required for proper sump drainage.

#### Water drain - Water cooled models

Connect the 3/4" male fitting of the condenser water drain, utilizing a second flexible tubing or a 3/8" O.D. copper tubing, to the open trapped and vented drain.

**NOTE.** The water supply and the water drain must be installed to conform with the local code. In some case a licensed plumber and/ or a plumbing permit is required.

#### F. FINAL CHECK LIST

1. Is the unit in a room where ambient temperatures are within a minimum of 10°C (50°F) even in winter months?
2. Is there at least a 15 cm (6") clearance around the unit for proper air circulation?
3. Are the storage bin and the unit in level? (IMPORTANT)
4. Have all the electrical and plumbing connections been made, and is the water supply shut-off valve open?
5. Has the voltage been tested and checked against the data plate rating?

6. Has the water supply pressure been checked to ensure a water pressure of at least 1 bar (14 psi).
7. Check all refrigerant lines and conduit lines to guard against vibrations and possible failure.
8. Have the bolts holding the compressor down been checked to ensure that the compressor is snugly fitted onto the mounting pads?
9. Have the bin liner and cabinet been wiped clean?

10. Has the owner/user been given the User Manual and been instructed on the importance of periodic maintenance checks?
11. Has the Manufacturer's registration card been filled in properly? Check for correct model and serial number against the serial plate and mail the registration card to the factory.
12. Has the owner been given the name and the phone number of the authorized SCOTSMAN Service Agency serving him?

### G. INSTALLATION PRACTICE

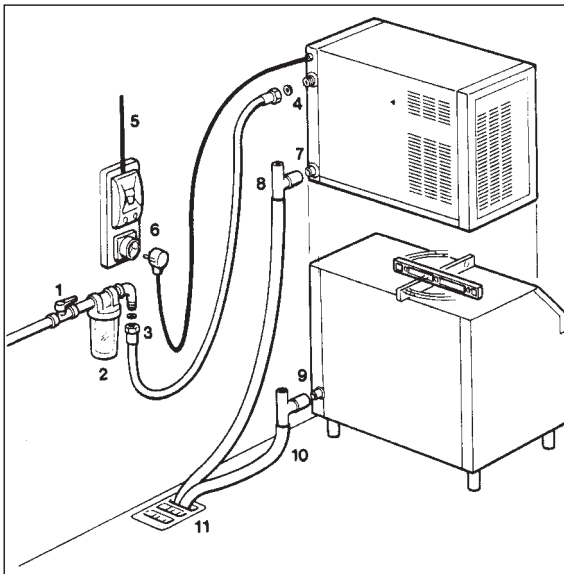

1. Hand shut-off valve
2. Water filter
3. Water supply line (flexible hose)
4. 3/4" male fitting
5. Power line
6. Main switch
7. Drain fitting
8. Vented drain
9. Drain fitting
10. Vented drain
11. Open trapped vented drain

**WARNING.** This icemaker is not designed for outdoor installation and will not function in ambient temperatures below 10°C (50°F) or above 40°C (100°F). This icemaker will malfunction with water temperatures below 5°C (40°F) or above 40°C (100°F).

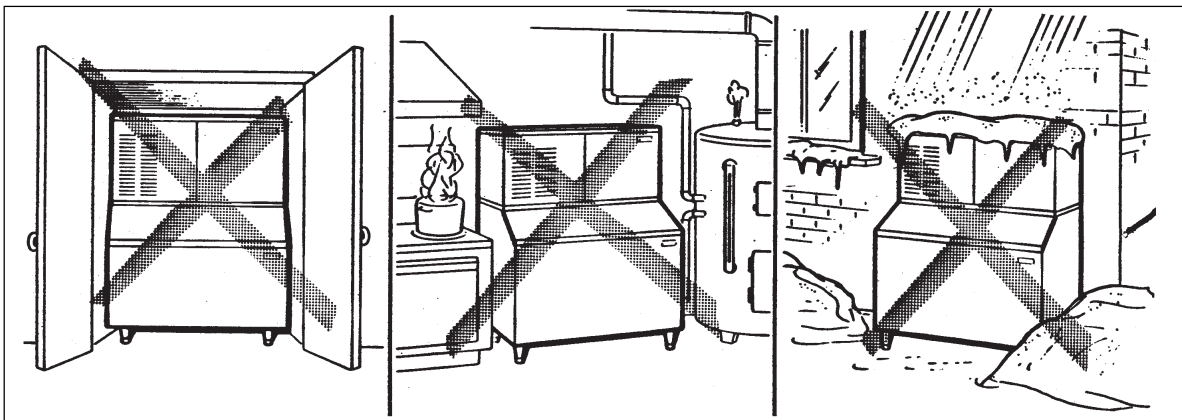

## OPERATING INSTRUCTIONS

### START UP

After having correctly installed the ice maker and completed the plumbing and electrical connections, perform the following "Start-up" procedure.

**A.** Remove the unit front panel and locate the two control boxes.

**B.** Through the control box cover locate the grooved head (similar to a fillister screw head) of the electronic program selector.



With the help of a regular screwdriver turn the selector head in the **OPERATION** position. (The screwdriver bit must fit the head slot end to end, this to avoid to spoil the selector head slot).

**C.** Give power to the unit to start it up by switching "ON" the power line main disconnect switch.

**NOTE.** Every time the unit returns under power, after having been switched off, both the water inlet valve, the hot gas valve get energized for a period of 5 minutes, thus to admit new water to the machine sump reservoir to fill it up and, eventually, to wash-off any dirt that can have deposited in it during the unit off period (Fig.1).

**D.** During the water filling operation, check to see that the incoming water dribbles, through the evaporator platen dribbler holes, down into the sump reservoir to fill it up and also that the incoming surplus of water flows out through the overflow pipe into the drain line. During the water filling phase the components energized are:

**WATER INLET SOLENOID VALVES**

**HOT GAS SOLENOID VALVES**

**WATER DRAIN SOLENOID VALVES** for the first 15 ÷ 20 seconds.

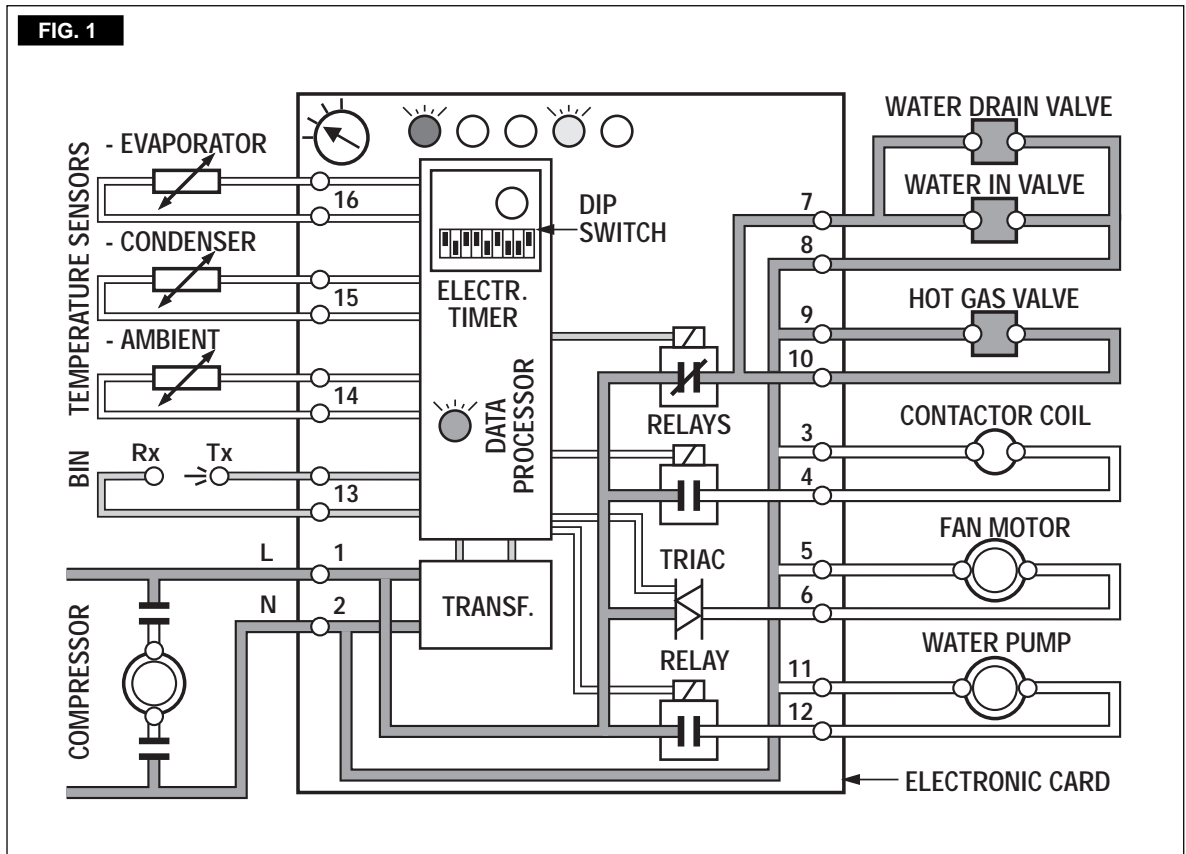

**NOTE.** If in the 5 minutes length of the water filling phase the machine sump reservoir does not get filled with water up to the rim of the overflow pipe, it is advisable to check:

1. The water pressure of the water supply line that must be at least **1 bar (14 psig) Minimum** (Max 5 bar-70 psig).
2. The filtering device installed in the water line that may reduce the water pressure below the Minimum value of 1 bar (14 psig).
3. Any clogging situation in the water circuit like the inlet water strainer and/or the flow control.

E. At completion of the water filling phase (5 minutes) the unit passes automatically into the freezing cycle with the start up of:

**COMPRESSOR**  
**WATER PUMPS**

**FAN MOTOR** (in air cooled version) controlled by the condensing temperature sensor located within the condenser fins (Fig.2).

**OPERATIONAL CHECKS**

F. Install, if necessary, the refrigerant service gauges on both the high side and low side Schröder valves to check the compressor head and suction pressures.

**NOTE.** On air cooled models the condensing pressures in both the refrigerant systems are controlled by two different pressure controls set between 13 and 14 bar (180÷195 psig) the right side and between 13.5 and 14.5 bar (190÷205 psig) the left side. In the water cooled models the discharge pressure is kept constant at the value of 14 bars (195 psig) by means of two water regulating valves located on the water supply line to the condensers. In case of condenser clogging such to prevent the proper flow of the cooling air or, in case the fan motor is out of operation or shortage of water in the water cooled condenser, the condenser temperature rises and when it reaches **70° C (160° F)** - for air cooled version - and **62° C (145° F)** - for water cooled version - the condenser temperature sensor shuts-off the ice maker with the consequent light-up of the **RED WARNING LIGHT** (Fig. 3).



After having diagnosed the reason of the rise of temperature and removed its cause, it is necessary to turn the head of the selector always using an appropriate scwdriver - first on the **RE-SET** position then return it on previous **OPERATION** position, thus to put the machine in condition to initiate a new freezing cycle. The same can also be done by just switching OFF and ON the unit at main line switch. In both cases the machine restarts with the usual 5 minutes water filling phase in order to provide enough water into the sump tank.

**FIG.2**

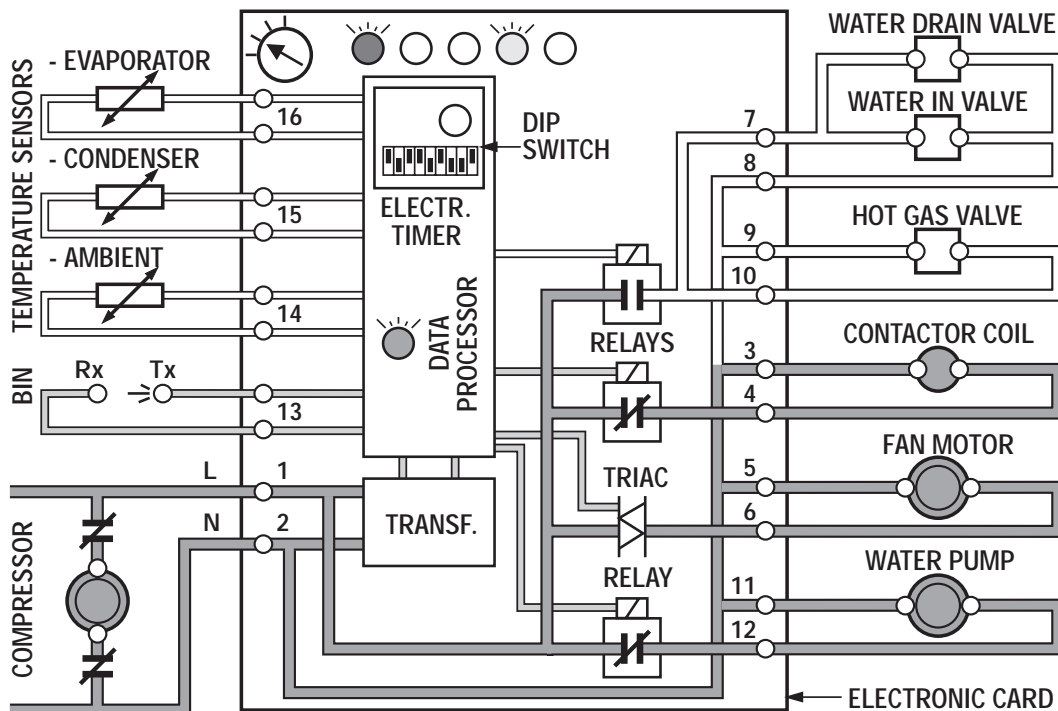

**G.** Check to see through the ice discharge opening that the self propelled spray bar is correctly rotating and that the water jets evenly reach the interior of the inverted mold cups, also make sure that there is not excessive water spilling out through the opening.

**H.** The ice making process takes place thereby, with the water sprayed into the molds that gets gradually refrigerated by the heat exchange with the refrigerant flowing into the evaporator serpentine. During the freezing process, when the evaporator

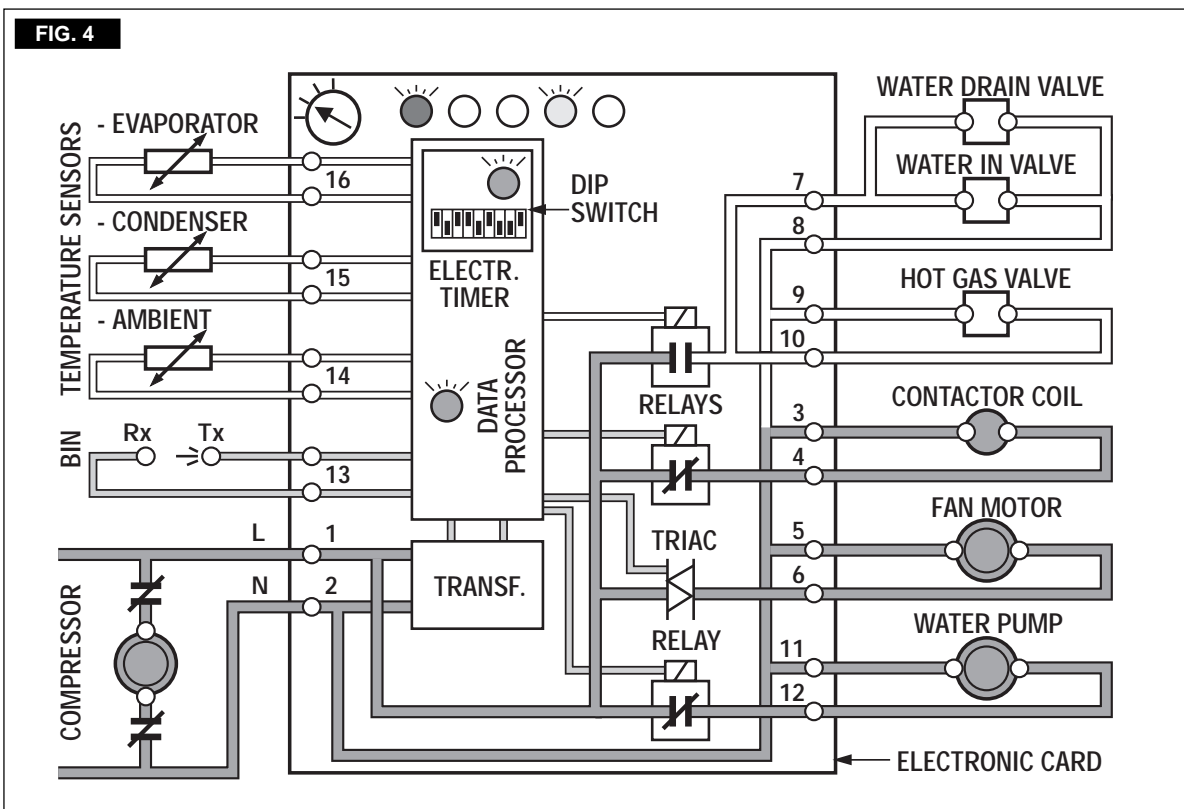
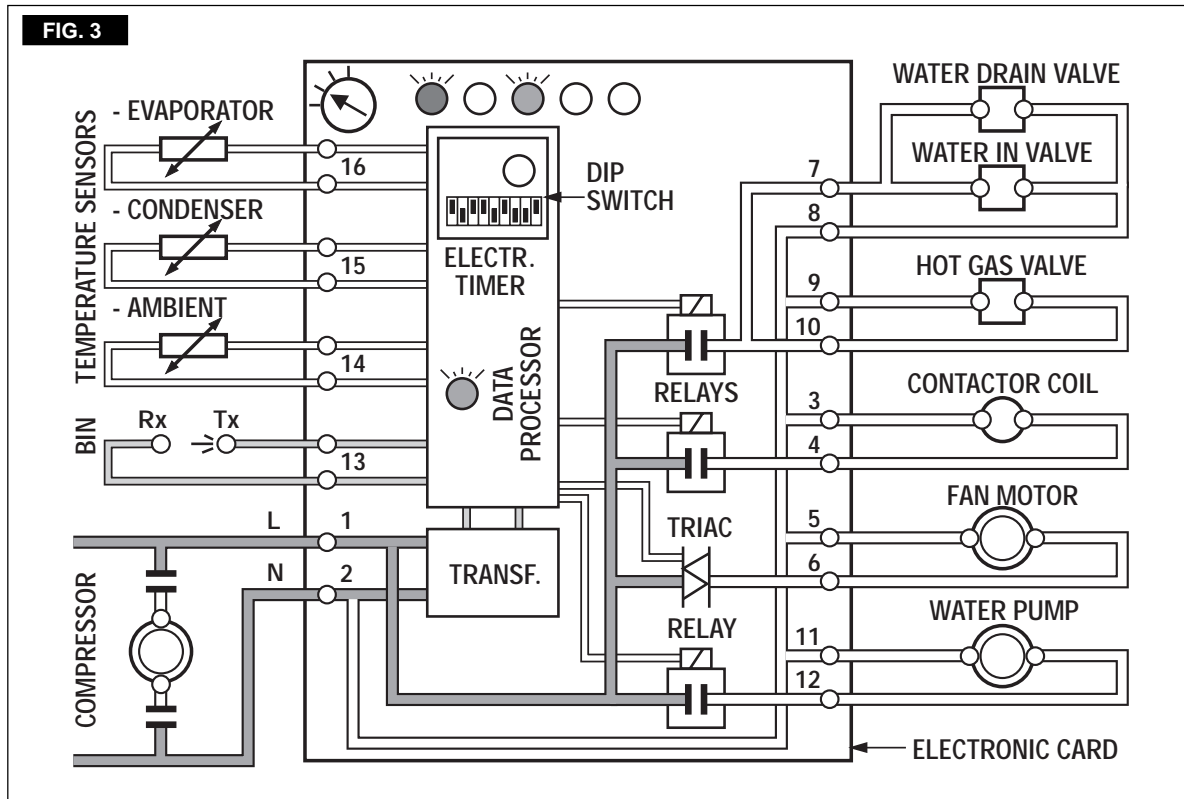

temperature falls below an established value, to the evaporator temperature sensor supplies a low voltage power signal to the electronic control device (P.C. BOARD) in order to activate an electronic timer. This one takes over the control of the freezing cycle up to the complete formation of the ice cubes (Fig.4).

**NOTE.** The length of the entire freezing cycle is governed by the evaporator temperature sensor which has its probe placed in contact with the evaporator serpentine (Non adjustable) in combination with the electronic timer (Adjustable) incorporated in the P.C. BOARD).  
The timer adjustment is factory set in consideration of the cooling version and of the ice cube size (Small, Medium, Large). It is possible, however, to modify the timed length of the freezing cycle, by changing the **DIP SWITCH** keys setting.  
In Table B of PRINCIPLE OF OPERATION are shown the various time extensions of the freezing cycle second phase, in relation with the different DIP SWITCH keys settings.

**WATER INLET SOLENOID VALVES**

**HOT GAS VALVES**

**WATER DRAIN SOLENOID VALVE/S** for the first 15 ÷ 20 seconds.

**NOTE.** The length of the defrost cycle is determined by the DIP SWITCH keys setting in conjunction with the ambient temperature sensor located just in front of the condenser. The length of defrost cycle can be adjusted by changing the combination setting of keys 5, 6 and 7 of **DIP SWITCH** as illustrated on Table C of PRINCIPLE OF OPERATION. As shown, per each individual keys combination, it is possible to have a different length of the defrost cycle in relation to the different ambient temperature situations; shorter when the ambient temperature is high and longer in colder ambients to partially compensate the length of the freezing cycle, which is longer in high ambient temperatures and shorter in low ones.

I. After about 17-20 minutes from the beginning of the freezing cycle, in an hypothetic ambient temperature of 21°C, the defrost cycle takes place with the hot gas and the water inlet valves being simultaneously activated (Fig.5). The electrical components in operation are:

J. Check, during the defrost cycle, that the incoming water flows correctly into sump reservoir in order to refill it and that the surplus overflows through the overflow drain tube.

K. Check the texture of ice cubes just released. They have to be in the right shape with a small depression of about 5-6 mm in their crown. If not, wait for the completion of the second cycle before performing any adjustment.

- COMPRESSOR**
- WATER PUMPS**

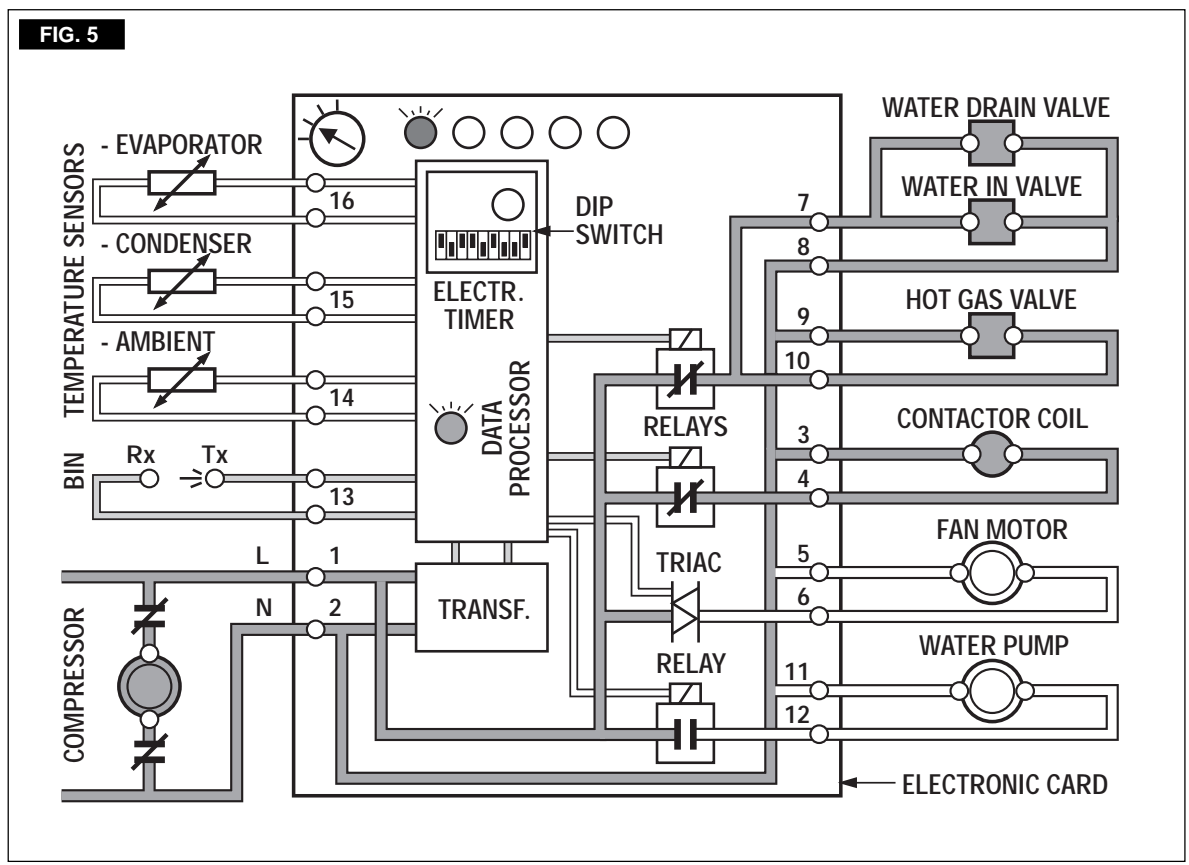

If required, the length of the timed freezing cycle can be modified by changing the **DIP SWITCH** keys setting as illustrated in OPERATING PRINCIPLE.

If the ice cubes are shallow and cloudy, it is possible that the ice maker runs short of water during the freezing cycle second phase or, the quality of the supplied water requires the use of an appropriate water filter or conditioner.

**L.** To be sure of the correct operation of ice level control device, place one hand between its sensing "eyes" to interrupt the light beam. The **RED LIGHT** located in the front of the P.C. BOARD goes immediately OFF, and after 60 seconds, the unit stops with the simultaneous glowing of the **2nd YELLOW LIGHT** to monitor the **BIN FULL** situation (Fig.6). Take the hand out from the ice level control sensors to allow the resumption of the light beam; the **RED LIGHT**, located in the front of the P.C. BOARD, will glow immediately. After approximately 6 seconds the ice maker resume its operation with the immediate glowing of the **FOURTH YELLOW LIGHT** indicating **UNIT IN OPERATION** and the extinguishing of the **"BIN FULL" YELLOW LIGHT**.



**NOTE.** The **ICE LEVEL CONTROL (INFRARED SYSTEM)** is independent from the temperature however, the reliability of its detection can be affected by external light radiations or by any sort of dirt and scale sediment which may deposit directly on the light source and on the receiver.

To prevent any possible ice maker malfunction, due to negative affection of the light detector, it is advisable to locate the unit where it is not reached by any direct light beam or light radiation, also it is recommended to keep the bin door constantly closed and to follow the instructions for the periodical cleaning of the light sensor elements as detailed in the **MAINTENANCE AND CLEANING PROCEDURES**.

**M.** Remove the refrigerant service gauges if fitted and re-fit the unit service panels previously removed.

**N.** Instruct the owner/user on the general operation of the ice machine and about the cleaning and care it requires.

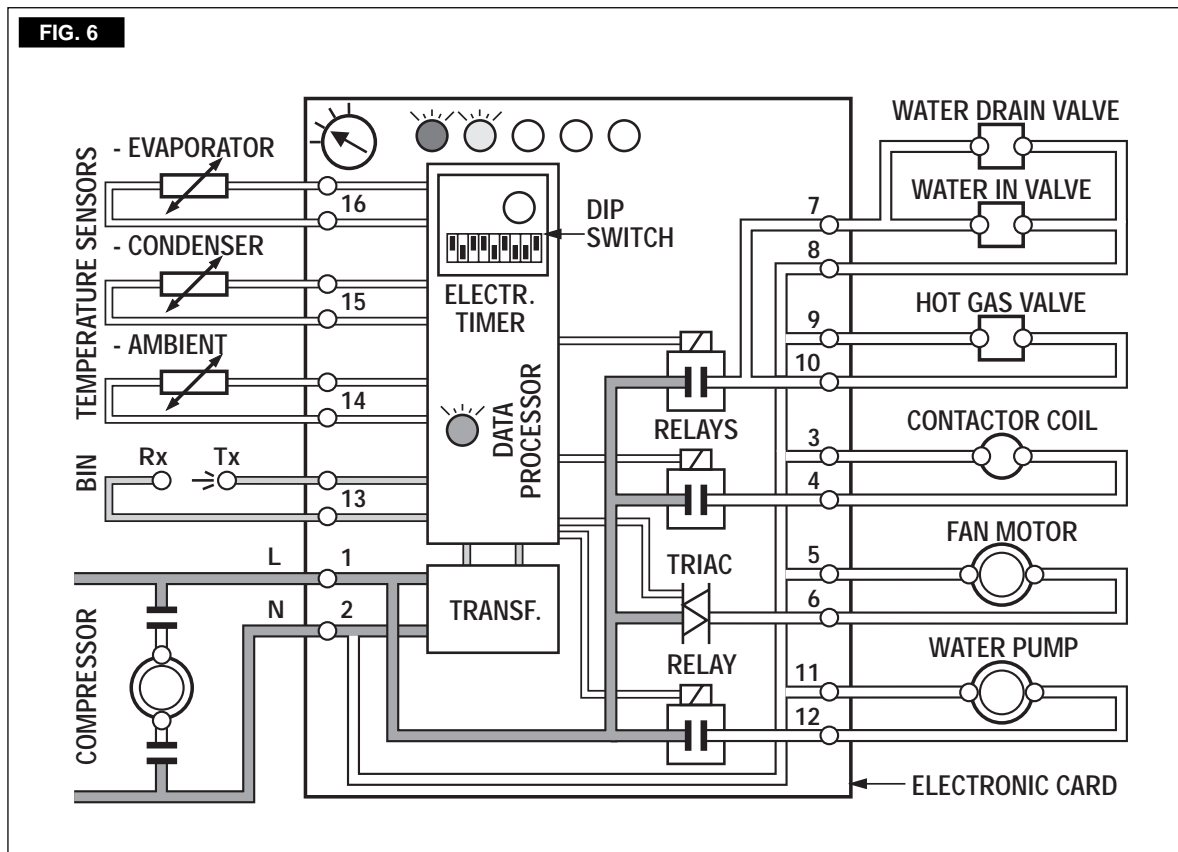

## PRINCIPLE OF OPERATION

### How it works

In the **SCOTSMAN** Modular Cubers MC 1210 the water used to make the ice is kept constantly in circulation by an electric water pumps (one for each evaporator) which primes it to the nozzles of the self propeller spray bar from where it is diverted into the inverted mold cups of the evaporator (Fig. B).

A small quantity of the sprayed water freezes into ice; the rest of it cascades by gravity into the sump assembly below for recirculation.

### FREEZING CYCLE (Fig. A)

The hot refrigerant gas discharged out from the compressor reaches the condenser where, being cooled down, condenses into liquid. Flowing into the liquid line it passes through the drier filter, then it goes all the way through the capillary tube where, due to the heat exchanging action, it loses some of its heat content so that its pressure and temperature are lowered as well.

Next the refrigerant enters into the evaporator serpentine (which has a larger I.D. than the capillary) and starts to boil off; this reaction is emphasized by the heat transferred by the sprayed water.

The refrigerant then increases in volume and changes entirely into vapor.

The vapor refrigerant then passes through the suction accumulator (used to prevent that any small amount of liquid refrigerant may reach the compressor) and through the suction line. In both the accumulator and the suction line it exchanges heat with the refrigerant flowing into the capillary tube (warmer), before to be sucked in the compressor and to be recirculated as high pressure, high temperature gas.

The freezing cycle is controlled by the evaporator temperature sensor (which has its probe in contact with the evaporator serpentine) that determines the length of the cycle first portion.

When the temperature of the evaporator serpentine drops to a pre-set value, the evaporator sensor probe changes its electrical resistance allowing a low voltage current (8-10 volts) to flow to the P.C. BOARD which in turn activates an electronic timer.

The timer, which is built-in the P.C. BOARD, takes over, from the evaporator temperature sensor, the control of the freezing cycle up to its completion.

**NOTE.** *The change of the electric potential of the evaporator sensor with the consequent activation of the timer (Time mode) is signalled by the glowing-up of the RED LED located beside the FREEZING yellow one in the front of the P.C. BOARD.*

**ATTENTION.** In case, after 15 minutes from the beginning of the freezing cycle, the temperature of the evaporator sensor probe is higher than 0°C (32°F) (shortage of refrigerant, inoperative hot gas valve, etc.) the P.C. BOARD switch OFF immediately the unit with the simultaneous blinking of the WARNING RED LED.

The length of this second portion of the freezing cycle is pre-fixed and related to the setting of the first four DIP SWITCH keys which is made in relation with the different unit version.

In Table B are indicated the various lengths of the second portion of freezing cycle (Time mode) in relation to the different combinations of the DIP SWITCH KEYS.

In Table A herebelow are illustrated the DIP SWITCH keys combinations for the different unit versions as they are set in the factory.

TAB. A		DIP SWITCH KEYS FACTORY SETTING COMBINATIONS									
DIP SWITCH		1	2	3	4	5	6	7	8	9	10
MCL 1210 A	ON	■	■	■		■	■			■	■
	OFF				■			■	■		
MCL 1210 A	ON		■		■	■	■			■	■
	OFF	■		■				■	■		
MCL 1210 W	ON	■	■	■				■		■	■
	OFF				■	■	■		■		
MCL 1210 W	ON		■		■			■		■	■
	OFF	■		■		■	■		■		

FIG. A

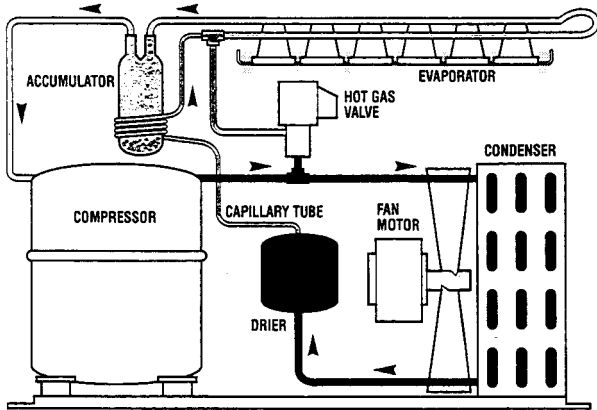

FIG. B

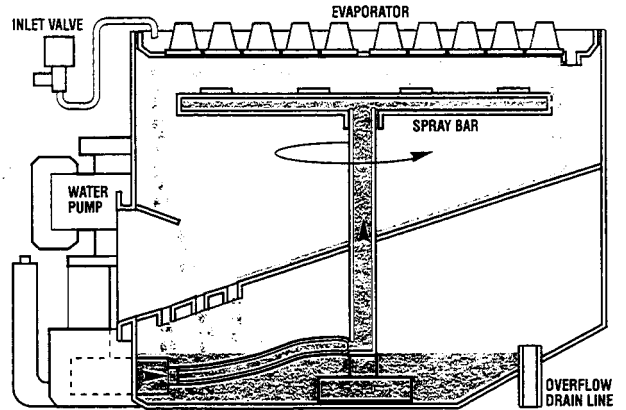

FIG. C

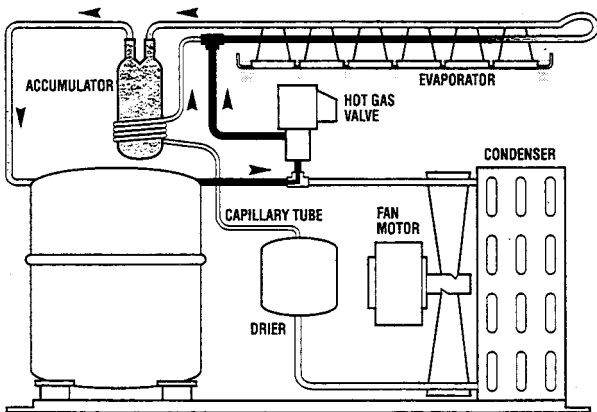
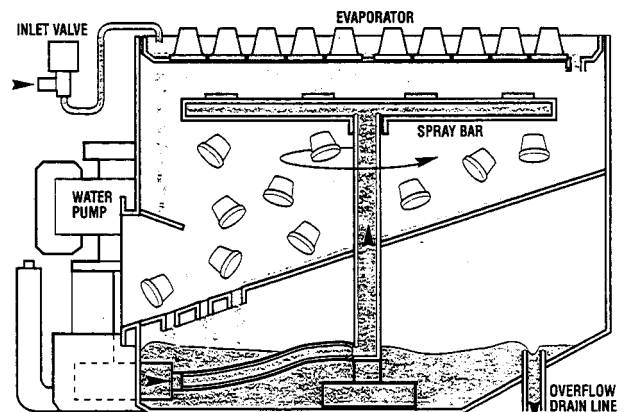

FIG. D



The electrical components in operation during the freezing cycle are:

**COMPRESSOR**

**FAN MOTOR** (in air cooled version)

**WATER PUMPS**

**CONTACTOR COIL**

and during the second phase of freezing cycle (Time mode) they are joined by the

**ELECTRONIC TIMER**

The refrigerant head pressure, in the course of the freezing cycle, ranges between 13 and 14 bars (180-195 psig) the right side and between 13.5 and 14.5 bar (190÷205 psig) the left side being controlled by two pressure controls (air cooled version or, it is kept constant at 14 bars (195 psig) by means of the water regulating valve (water cooled version).

**NOTE.** On this model the condenser sensors are used just to switch off the unit in case the condensing temperature rise up to more than 77°C (for air cooled version) or more than 62°C (for water cooled version) for one of the following abnormal reasons:

**CLOGGED CONDENSER** (Air cooled version)

**FAN MOTOR OUT OF OPERATION** (Air cooled version)

**INSUFFICIENT FLOW OF COOLING WATER** (Water cooled version)

**AMBIENT TEMPERATURE HIGHER THEN 40°C (100°F)**

it causes the total and immediate SHUT-OFF of the machine in order to prevent the unit from operating in abnormal and dangerous conditions.

When the ice maker stops on account of this protective device, there is a simultaneous glowing of the **RED LED**, warning the user of the **Hi Temperature** situation.

After having eliminated the source of the condenser hi-temperature, to restart the machine it is necessary first, to rotate for a while the program selector on **RE-SET** position then, to rotate it again on **OPERATION** position.

The same can be done by just switching OFF and ON the unit at main line switch.

The ice machine resumes its normal operation by going through the 5 minutes water filling phase.

At the start of the freezing cycle the refrigerant suction or lo-pressure lowers rapidly to **4.4 bars-60 psig** then it declines gradually - in relation with the growing of the ice thickness - to reach, at the end of the cycle, approx. **2.5 bar - 35 psig** with the cubes fully formed in the cup molds.

The total length of the freezing cycle ranges from 20 to 25 minutes.

**DEFROST OR HARVEST CYCLE** (Fig. C)

As the electronic timer has carried the system throughout the second phase of freezing cycle, the defrost cycle starts.

**ATTENTION.** In case the unit be able to reach 0°C (32°F) evaporating temperature within 15 minutes, but after 45 minutes from the beginning of the freezing cycle it has not yet reached the evaporator temperature of -15°C (5°F) the machine goes straight into the defrost cycle omitting the timed portion of the freezing cycle relied to the setting of the first four DIP SWITCHES.

**NOTE.** The length of the defrost cycle is predetermined by the setting of the DIP SWITCH KEYS NO. 5, 6 and 7 and it is relied as well to the ambient temperature as detailed in Table C.

The electrical components in operation during this phase are:

**COMPRESSOR**

**WATER PUMPS**

**WATER INLET SOLENOID VALVES**

**HOT GAS SOLENOID VALVES**

**WATER DRAIN SOLENOID VALVES** for the first 15 ÷ 20 seconds.

The incoming water, passing through the water inlet valve and the flow control, runs over the evaporator platen and then flows by gravity through the dribbler holes down into the sump/reservoir (Fig. D).

The water filling the sump/reservoir forces part of the surplus water from the previous freezing cycle to go out to the waste through the overflow pipe. This overflow limits the level of the sump water which will be used to produce the next batch of ice cubes.

Meanwhile, the high pressure, high temperature refrigerant, discharged from the compressor, flows through the hot gas valve directly into the evaporator serpentine by-passing the condenser. The hot gas circulating into the serpentine of the evaporator warms up the copper molds causing the defrost of the ice cubes. The ice cubes, released from the cups, drop by gravity onto a slanted cube chute, then through a curtained opening they fall into the storage bin.

**NOTE.** The length of the defrost cycle, factory set, can vary in accordance with the actual ambient temperature (as shown on Table C). For instance, in high ambient temperature situation, it can be reduced to recover some of the time spent for the longer freezing cycle.

At the end of the defrost cycle, both the hot gas and the water inlet valves close, so the machine initiates another cycle.

**OPERATION - CONTROL SEQUENCE**

At the start of the freezing cycle, the evaporator temperature sensor controls the length of the first part of the freezing cycle. As it reaches a predetermined temperature, it supplies a low voltage current to the P.C. BOARD in order to activate the electronic timer which, takes over the control of the freezing cycle for a pre-fixed time, according to the DIP SWITCH keys setting (see Tab. B).

**NOTE.** The evaporator temperature sensor, factory pre-set, is the same for all the models and is not adjustable in the field.

Once completed the freezing cycle 2nd phase the system goes automatically into the defrost cycle which also has a pre-fixed length that can slightly change in relation to the ambient temperature as shown in Table C. At completion of the defrost cycle the P.C. BOARD commands the unit to start again a new freezing cycle.

**OPERATION - ELECTRICAL SEQUENCE**

The following charts illustrate which switches and which components are ON or OFF during a particular phase of the icemaking cycle. Refer to the wiring diagram for a reference. Remember, the wiring diagram shows the unit as it is in the Timed Freeze Cycle.

**BEGINNING FREEZE**

<b>Electrical components (Loads) .</b>	<b>ON</b>	<b>OFF</b>
Compressor .....	•	
Fan Motor (Air cooled only) and TRIAC	•	
Hot Gas Valves .....		•
Inlet Water Valves .....		•
P.C. Board Relay 1 Coil .....		•
P.C. Board Relay 2 & 3 Coil .....	•	
Water Pumps .....	•	
Contactactor Coil .....	•	
Electronic Timer .....		•

<b>Electronic Controls &amp; Sensors ..</b>	<b>ON</b>	<b>OFF</b>
Evaporator Sensor .....		•
Condenser Sensor .....	•	
Ambient Sensor .....		•
Ice Level Control .....	•	

**TIMED FREEZE**

<b>Electrical components (Loads) .</b>	<b>ON</b>	<b>OFF</b>
Compressor .....	•	
Fan Motor (Air cooled only) and TRIAC	•	•
Hot Gas Valves .....		•
Inlet Water Valves .....		•
P.C. Board Relay 1 Coil .....		•
P.C. Board Relay 2 & 3 Coil .....	•	
Water Pumps .....	•	
Contactactor Coil .....	•	
Electronic Timer .....	•	

<b>Electronic Controls &amp; Sensors .</b>	<b>ON</b>	<b>OFF</b>
Evaporator Sensor .....	•	
Condenser Sensor .....	•	•
Ambient Sensor .....		•
Ice Level Control .....	•	

**HARVEST**

<b>Electrical components (Loads) .</b>	<b>ON</b>	<b>OFF</b>
Compressor .....	•	
Fan Motor (Air cooled only) and TRIAC .		•
Hot Gas Valves .....	•	
Inlet Water Valves .....	•	
P.C. Board Relay 1 & 2 Coil .....	•	
P.C. Board Relay 3 Coil .....	•	
Water pumps .....	•	
Contactactor Coil .....	•	
Electronic Timer .....	•	

<b>Electronic Controls &amp; Sensors .</b>	<b>ON</b>	<b>OFF</b>
Evaporator Sensor .....		•
Condenser Sensor .....		•
Ambient Sensor .....	•	
Ice Level Control .....	•	

**OPERATING CHARACTERISTICS**

On air cooled models during the freezing cycle the discharge pressures are kept between 13 and 14 bar (180÷195 psig) in the right system and between 13,5 and 14,5 bar (190÷205 psig) in the left one by two separate pressure controls and at the same time the suction pressure will gradually decline, reaching its lowest point just before harvest. Compressor amps experience a similar drop.

On water cooled, the discharge pressure is constant, maintained during the freeze cycle by the water regulating valve at 14 bars (195 psig). However, suction pressure and compressor amps will still decline as the machine freezes ice.

**Freeze Cycle**

Average Discharge Pressure A/C:

Right System: 13÷14 bar (180÷195 psig)  
 Left System: 13.5÷14.5 bar (190÷205 psig)

Average Discharge Pressure W/C: 14 bars (195 psig)

Suction Pressure End Freeze Cycle: 2.5 bar (35 psig)

**REFRIGERANT CHARGE R 404 a**

Air Cooled Version: 2 x 1200 gr (2 x 42 oz)

Water Cooled Version: 2 x 700 gr (2 x 24.5 oz)

**NOTE.** Before charging the refrigerant system always check the type of refrigerant and quantity as specified on the individual ice machine dataplate. The refrigerant charges indicated are related to average operating conditions.

**WARNING.** As R 404 a is a blend of different types of refrigerants it is imperative to charge the system only in liquid phase in order to avoid to alter their mix-up percentage.

**COMPONENTS DESCRIPTION**

**A. EVAPORATOR TEMPERATURE SENSOR**

The evaporator temperature sensor probe, located in contact with the evaporator serpentine, detects the dropping of the evaporator temperature during the freezing cycle and signals it by supplying a current flow to the micro processor of P.C. BOARD.

According to the current received, the evaporator sensor supplies power to the P.C. BOARD first, when it reaches 0°C (32°F), second at -15°C (5°F); in this second case it supply power to the electronic timer built into the P.C. BOARD so that it may take control of the fength of the 2nd phase of freezing cycle.

The length of the timed phase is pre-f ixed by the setting of the keys 1, 2, 3 and 4 of the DIP SWITCH.

The activation of the electronic timer (-15°C - 5°F) is monitored by the lighting up of the **RED LED** placed in the front of the P.C. BOARD.

This lighting up occures usually in the mid period of the freezing cycle and signals the switching from the first to the second phase of the freezing cycle.

**NOTE.** Whenever, after 15 minutes from the beginning of the freezing cycle, the evaporating temperature have not yet reached the value of 0°C (32°F), the P.C. BOARD switches OFF the machine with the **BLINKING** of RED LED.

**B. CONDENSER TEMPERATURE SENSOR**

The condenser temperature sensor probe, located within the condenser fins (air cooled version) or in contact with the tube coil (water cooled version) detects the condenser temperature variations and signals them by supplying current, at low voltage, to the P.C. BOARD. In case the condenser temperature rises and reaches 70°C (160°F) - on air cooled models - or 62°C (145°F) - on water cooled models - the current arriving to the micro processor is such to cause an immediate and total stop of the machine operation.

**C. AMBIENT TEMPERATURE SENSOR**

The probe of this sensor, located in the front of the ice maker condenser (Air cooled version) and on the water supply line to the condenser (Water cooled version) has the function to detect the ambient or the water temperature and, by changing its own electrical resistance, supplies a different current flow to the P.C. BOARD.

This different current flow received by the P.C. BOARD, is elaborated by the micro processor in order to extend or shorten the defrost cycle length (longer in cold ambient situations, shorter in warm ones).

#### D. ICE BIN LEVEL LIGHT CONTROL

The electronic ice bin level control, located into the storage bin, has the function to stop the operation of the ice machine when the light beam between the light source and the sensor is interrupted by the ice cubes stored into the bin. When the light beam is interrupted the RED LED located in the front of the P.C. BOARD goes off; in case the light beam is constantly interrupted for more than 60 seconds, the ice machine stops with the glowing-up of the **2nd YELLOW LED** to monitor the situation of ice bin full.

The 60 seconds of delay prevent that an ice scoop movement or the ice dropping through the ice chute (interrupting for a while the light beam) can stop the operation of the unit.

As soon as the ice is scooped out (with the resumption of the light beam between the two infrared sensor of ice level control) the RED LED is lighted up and after 6 seconds the ice machine restarts again with the extinguishing of the 2nd YELLOW LED.

#### E. P.C. BOARD (Data processor)

The **P.C. BOARD**, fitted in its plastic box located in the front of the unit, consists of two separated printed circuits one at high and the other at low voltage integrated with a program selector, of five aligned **LEDS** monitoring the operation of the machine, of two extra monitoring **RED LEDS**, of one **DIP SWITCH** with ten keys, of input terminals for the leads of the sensor probes and input and output terminals for the leads of the ice maker electrical wires.

The P.C. BOARD is the brain of the system and it elaborates, through its micro processor, the signals received from the four sensors in order to control the operation of the different electrical components of the ice maker (compressor, water pump, solenoid valves, etc.).

By turning the program selector it is possible to put the unit in the following different situations:

**CLEANING/RINSING.** The water pump is the only electrical component in operation and it must be used during the cleaning or the rinsing procedure of the water system of ice machine.

**STAND BY.** The unit remain under electrical power but OUT of operation. It can be used by the service engineer in order to stop the unit during the service and inspection operations.

**IN OPERATION.** The unit is running through the freezing and defrost cycles stopping automatically only at full bin situation.

**RE-SET/HI TEMPERATURE.** To be selected to resume the unit operation when the ice maker shuts off due to the intervention of the condenser temperature sensor (too high condensing temperature).

The five LEDES, placed in a row in the front of the P.C. BOARD, monitor the following situations:

#### GREEN LIGHT

Unit under electrical power

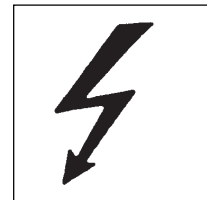

#### YELLOW LIGHT

Unit shut-off at full storage bin

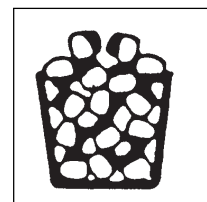

#### RED LIGHT

Unit shut-off due to hi condensing temperature

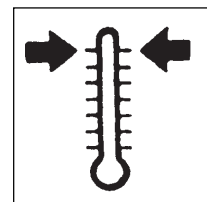

#### blinking

Unit shut-off due to too hi evaporating temperature

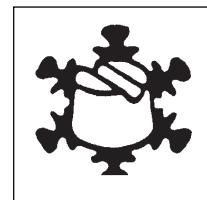

#### YELLOW LIGHT

Unit in freezing operation

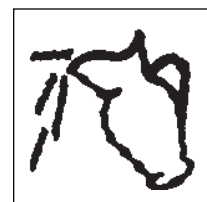

#### YELLOW LIGHT

Unit cleaning/rinsing mode

#### F. DIP SWITCH

The P.C. BOARD which controls the entire operation of the ice maker, has a **DIP SWITCH with ten switching keys** which allow to set up the micro processor program in order to extend or to shorten the length of freezing and defrost cycles in relation to the different models and versions of ice machines.

The **DIP SWITCH first four keys setting** determines the length of the 2nd phase of freezing

cycle (controlled by the electronic timer) as detailed in table B.

TAB. B		LENGHT OF TIMED PORTION OF FREEZING CYCLE ACCORDINGLY TO THE DIP SWITCH SETTING COMBINATIONS											
		1	2	3	4								
1	ON OFF	█	█	█	█	25 min.	8	ON OFF	█	█	█	█	11 min.
2	ON OFF	█	█	█	█	23 min.	9	ON OFF	█	█	█	█	9 min.
3	ON OFF	█	█	█	█	21 min.	10	ON OFF	█	█	█	█	7 min.
4	ON OFF	█	█	█	█	19 min.	11	ON OFF	█	█	█	█	5 min.
5	ON OFF	█	█	█	█	17 min.	12	ON OFF	█	█	█	█	3 min.
6	ON OFF	█	█	█	█	15 min.	13	ON OFF	█	█	█	█	1 min.
7	ON OFF	█	█	█	█	13 min.							

The **DIP SWITCH KEYS 5, 6 AND 7 setting** determines the length of the defrost cycle

according to the ambient temperature sensors as specified in table C.

TAB. C		LENGHT OF DEFROST CYCLE (IN SEC.) ACCORDING TO THE AMBIENT TEMPERATURE AND TO THE DIP SWITCH SETTING COMBINATIONS										
		5	6	7	0±5 °C	5±10 °C	10±15 °C	15±20 °C	20±25 °C	25±30 °C	30±35 °C	35±40 °C
ON	OFF	█	█	█	180"	150"	120"	90"	90"	90"	90"	90"
ON	OFF	█	█	█	210"	180"	150"	120"	120"	120"	90"	90"
ON	OFF	█	█	█	240"	210"	180"	150"	150"	120"	120"	90"
ON	OFF	█	█	█	240"	210"	180"	150"	150"	120"	120"	120"
ON	OFF	█	█	█	270"	240"	210"	180"	180"	150"	150"	150"

The **8th DIP SWITCH key** allows to make a rapid check up of the P.C. BOARD output connections (compressor, water pump, fan motor, water inlet and hot gas solenoid valves) energizing them in rapid sequence (2 seconds) one by one. **DURING THE AUTOMATIC OPERATION OF THE ICE MAKER THIS KEY MUST BE SET IN OFF POSITION.**

**ATTENTION.** The check up of the P.C. BOARD output must be performed in a very short time in order to avoid frequent start and stop (every few seconds) of the electrical component which may damage them specially the compressor.

The **9th key** allows the operation of the water pump even during the defrost cycle (first 15 or 30 seconds), as required when it is necessary to drain out the remaining water from the sump.

The **10th key** is used to supply power to the water pump for the first 15 seconds of the defrost cycle - position OFF - or for the first 30 seconds - position ON (MC 1210).

**G. WATER SPRAY BAR (4 per unit)**

On Modular Cuber the spray bar is self rotating being propelled by a stream of water passing through an hole located in one arm of the spray bar and, through its four nozzles, the pumped water is sprayed in each individual cup to be frozen into ice.

**H. WATER PUMP**

The water pump operates continually throughout the freezing and detrost cycle to prime the water from the sump to the self propelling spray bar and, through the four spray nozzles, it sprays it into the inverted cup molds to be frozen into crystal clear ice cubes.

The water pump remains in operation even during the detrost cycle in order to help the release of the ice cubes.

It is recommended that the pump motor bearings be checked at least every six months.

#### I. WATER INLET SOLENOID VALVE - 3/4 GAS MALE FITTING

The water inlet solenoid valve is activated by the micro processor of the P.C. BOARD during the first 5 minutes of water filling phase and as well during the defrost cycle.

When energized it allows a metered amount of incoming water to flow over the evaporator cavity to assist the hot gas in defrosting the ice cubes. The water running over the evaporator cavity drops by gravity, through the dribbler holes of the platen, into the sump reservoir where it will be sucked by the water pump and primed to the spray system.

#### J. HOT GAS SOLENOID VALVE

The hot gas solenoid valve consists basically in two parts: the valve body and the valve coil. Located on the hot gas line, this valve is energized through the micro processor of P.C. BOARD during the defrost cycle and as well during the water filling phase.

During the defrost cycle the hot gas valve coil is activated so to attract the hot gas valve piston in order to give way to the hot gas discharged from the compressor to flow directly into the evaporator serpentine to defrost the formed ice cubes.

#### K. FAN MOTOR (Air cooled version)

The fan motor is controlled through the P.C. BOARD and the TRIAC by the condenser temperature sensor. Normally it operates only during the freezing cycle to draw cooling air through the condenser fins.

In the second part of the freezing cycle, the fan motor can run at intermittance as the condenser pressure must be kept between two corresponding head pressure values (13÷14,5 bars - 180÷205 psig).

#### L. COMPRESSOR

The hermetic compressor is the heart of the refrigerant system and it is used to circulate and retrieve the refrigerant throughout the entire

system. It compresses the low pressure refrigerant vapor causing its temperature to rise and become high pressure hot vapor which is then released through the discharge valve.

#### M. WATER REGULATING VALVE (Water cooled version)

This valve controls the head pressure in the refrigerant system by regulating the flow of water going to the condenser.

As pressure increases, the water regulating valve opens to increase the flow of cooling water.

#### N. CONTACTOR

Placed outside of the control box it is controlled by the P.C. BOARD in order to close or open the electrical circuit to the compressor.

#### O. WATER DRAIN SOLENOID VALVE

Energized by a special electronic timer during the first 15-20 seconds of defrost cycle, it diverts to the drain (from the sump tank) all the remaining water-rich of minerals-left from the previous freezing cycle, which is pumped out by the water pump.

#### P. WATER DRAIN ELECTRONIC TIMER

Located beside the contactor, it energizes the water drain valve for the first 15-20 seconds of the defrost cycle according to the setting of its knob.

**NOTE.** Adjust the knob of the water drain electronic timer in order that all remaining water of previous freezing cycle be pumped out from the sump tank.

## ADJUSTMENT, REMOVAL AND REPLACEMENT PROCEDURES

### A. ADJUSTMENT OF THE CUBE SIZE

**CAUTION.** Before performing actual adjustment of the cube size, check other possible causes for cube size problems, refer to the Service Diagnosis Section for problem review and analysis. Do not perform any adjustment till the icemaking system has progressed through several complete freezing and harvest cycle, to observe size and quality of ice cubes and whether or not the cube size problem exists.

**I.** If the cubes are shallow size (Indentation is too deep) probably the length of the second phase of the freezing cycle is too short so, to extend such length you have to:

1. Locate the DIP SWITCH on the front of the P.C. Board.
2. Take note of the combination of the first four DIP SWITCH KEYS and check the corresponding length of freezing cycle 2nd phase on Table B.
3. Change the same DIP SWITCH KEYS setting so that it will correspond to the combination on table B preceding the one remarked at step 2.  
This will allow an extension of the freezing cycle of two more minutes.
4. Observe the ice cubes in the next two harvests and eventually repeat steps 2 and 3 above until proper ice cubes size is achieved. See figure.

**II.** If the cubes are oversize size (Indentation is too full) probably the length of the second phase of the freezing cycle is too long. To shorten such length you have to:

1. Locate the DIP SWITCH on the front of the P.C. Board.
2. Take note of the combination of the first four DIP SWITCH KEYS and check the corresponding length of freezing cycle 2nd phase on Table B.
3. Change the same DIP SWITCH KEYS setting so that it will correspond to the combination on table B coming next to the one remarked at step 2.  
This will reduce an the freezing cycle length of two minutes.

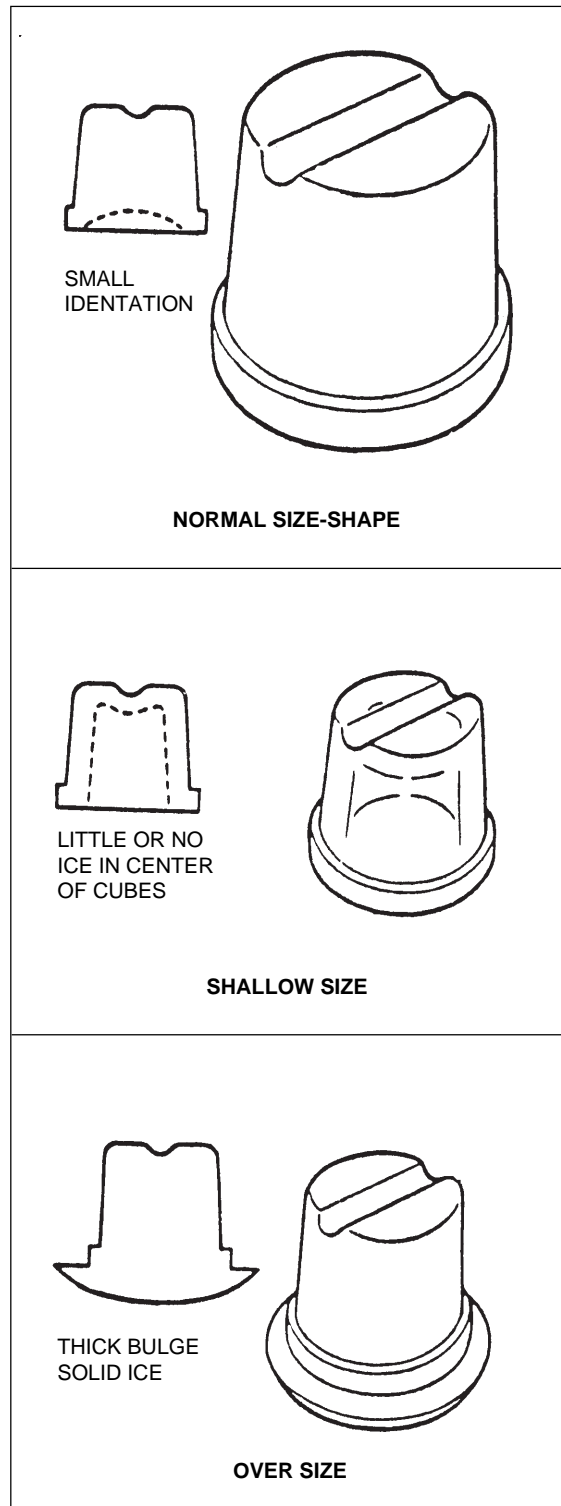

4. Observe the ice cubes in the next two harvests and eventually repeat steps 2 and 3 above until proper ice cubes size is achieved. See figure.

**B. REPLACEMENT OF EVAPORATOR TEMPERATURE SENSOR**

1. Remove front center panel as well as the two top sides ones.
2. Remove the evaporator insulation and disconnect the sensor probe from the serpentine.
3. Trace the evaporator sensor terminal plug on the rear side of the control box and remove it from its socket by carefully pulling out the terminal plug securing clip.
4. To install the replacement evaporator sensor follow the above steps in reverse.

**C. REPLACEMENT OF CONDENSER TEMPERATURE SENSOR**

1. Remove front center panel.
2. Trace the condenser sensor probe located within the condenser fins on air cooled version and with throw it.  
On water cooled version remove it by opening the plastic strap (reusable) securing the probe to the refrigerant liquid line.
3. Trace the condenser sensor terminal plug on the rear side of the control box and remove it from its socket by carefully pulling out the terminal plug securing clip.
4. To install the replacement condenser sensor follow the above steps in reverse.

**D. REPLACEMENT OF AMBIENT TEMPERATURE SENSOR**

1. Remove front center upper and lower panels.
2. Trace the ambient sensor probe held on its metal bracket in front of the condenser fins-on air cooled version-and remove it by unloosing its securing plastic clamp.  
On water cooled version, remove it by opening the plastic strap (reusable) securing the probe on the water supply line to the condenser.
3. Trace the ambient sensor terminal plug on the rear side of the control box and remove it from its socket by carefully pulling out the terminal plug securing clip.
4. To install the replacement ambient sensor follow the above steps in reverse.

**NOTE.** Both the condenser and ambient sensors are equipped by the same terminal plug and socket. To avoid confusion on their installation it must be observed that the condenser sensor terminal plug and its corresponding socket are of different colour compared to the other ones.

**E. REPLACEMENT OF ICE LEVEL LIGHT CONTROL**

1. Remove the front center panel and front left or right panel according to the location of the ice level control.
2. Trace the ice level light control terminal plug (the only one with four terminal pins) on the rear side of the control box and remove it from its socket by carefully pulling out the terminal plug securing clip.
3. Remove the ice chute where is located the ice level light control assy and remove it from its metal bracket by unloosing the two securing screws.
4. Remove the PVC plastic plug from unit base then with trow the entire ice level light control cable and terminal plug through the hole in the unit base.
5. To install the replacement ice level light control follow the above steps in reverse.

**NOTE.** Slip in the ice level control cable in the center of the plastic plug so to avoid any sort of contact with the unit frame.

**F. REPLACEMENT OF P.C. BOARD**

1. Remove front center panel.
2. Remove all sensor terminal plugs, located on the rear side of P.C. Board, by carefully releasing them out from their sockets clips.
3. Disconnect the terminal board connection plug from the rear side of P.C. BOARD then unloose the four screws holding the same to the plastic control box and remove it.
4. To install the replacement P.C. BOARD follow the above steps on reverse.

**G. REPLACEMENT OF THE WATER PUMP**

1. Remove left or right front panels.
2. Locate the water pump in the front left corner of the evaporator chamber.
3. Remove the plastic ice chute and through the ice discharge opening trace the plastic hose and disconnect it from the port of the pump body.
4. Unloose the screw and the yellow green ground wire. Trace the pump electrical wire leads and disconnect them.
5. Remove the two screws securing the pump to sump tank.

6. Pull out the pump assy from sump.
7. To install the replacement pump follow the above steps in reverse.

#### **H. REPLACEMENT OF WATER INLET SOLENOID VALVE**

1. Close the shut-off valve on the water supply line and disconnect it from the water inlet fitting at the rear of the modular cuber.
2. Remove the rear center panel and disconnect the electrical leads from the solenoid valve.
3. Unscrew the two screws securing the inlet solenoid valve to the cabinet.
4. Remove the corbin clamps and plastic hose; the valve is now free.
5. To install the replacement water inlet solenoid valve follow the above steps in reverse.

#### **I. TO REMOVE THE FLOW CONTROL**

1. Remove the rear center panel.
2. Locate the plastic hose connecting the water inlet solenoid valve to the copper water line going to the top of the evaporator chamber.
3. Unloose the two clamps securing the copper tube as well as the flow control to the plastic hose and withdraw the copper tube.
4. By means of a 4 MA screw withdraw the flow control assy from the inside of plastic hose.

#### **J. REPLACEMENT OF THE HOT GAS VALVE COIL**

1. Remove the front and the top center panel.
2. Remove the hardware securing the hot gas valve coil its body.
3. Trace the electric wires belonging to the hot gas valve coil and disconnect them; then lift the valve coil from the valve body.
4. To install the replacement hot gas valve coil follow previous steps in reverse.

#### **K. REPLACEMENT OF WATER DRAIN SOLENOID VALVE**

1. Remove the rear panel.
2. Trace and disconnect the electrical leads from the water drain solenoid valve coil.

3. Remove the corbin clamps and the plastic hoses from the valve.

4. Unloose the screws securing the valve to the unit base and remove it.

5. To install the replacement water drain solenoid valve follow the above steps in reverse.

**NOTE.** When installing the new valve pay attention to the water flow direction.

#### **L. REPLACEMENT OF THE WATER DRAIN ELECTRONIC TIMER**

1. Remove the front panel.
2. Unscrew the terminal wires holders of the electronic timer and disconnect the wires.
3. Remove, by pulling out its holding ring, the electronic timer from its bracket.
4. To install the replacement electronic timer follow previous steps in reverse.

**NOTE.** Adjust the electronic timer knob in order that all remaining water from previous freezing cycle be totally pumped out from the sump tank.

#### **M. REPLACEMENT OF FAN MOTOR**

1. Remove the front panel.
2. Unloose the screws securing the air cooled condenser to the unit frame and open it to gain the access to the fan motor.
3. Remove screws and yellow green ground wire. Trace the electrical leads of fan motor and disconnect them.
4. Remove the bolts securing the fan motor protection grid to the condenser shroud then remove the fan motor assembly.
5. With an appropriate allen wrench unsoolse the screw securing the fan blade to the fan motor shaft then unloose the nuts holding the fan motor to its protecting grid.
6. To install the replacement fan motor follow the above steps in reverse.

**NOTE.** When installing a new fan motor check that the fan blades do not touch any surface and move freely.

## N. REPLACEMENT OF SPRAY BAR

1. Remove the front right or left side panel and then the plastic ice chute.
2. Reach through the ice opening and feel for the spray bar.
3. Rotate spray bar so that one of its end is aligned with ice opening.
4. Grab the spray bar center and lift it up off the jet bearing hub together with its race washer; then draw it out through the ice opening.
5. To install the replacement spray bar follow above steps in reverse.

## O. REPLACEMENT OF DRIER

1. Remove the center front panel.
2. On air cooled version, unloose the screws securing the condenser to unit frame.
3. Recover the refrigerant from the system and transfer it in a bottle so to reclaim or recycle it.
4. Unsolder the refrigerant lines from the two ends of the drier.
5. To install the replacement drier remove factory seals and solder the refrigerant lines taking precautions to NOT OVERHEAT the drier body.
6. Thoroughly evacuate the system to remove moisture and non condensable after drier replacement.
7. Charge the system with refrigerant HP 81 by weight (see data plate of machine) and check for leaks.

**ATTENTION. SUVA HP 81 as it is a blend of different type of refrigerants it has to be charged only in the liquid phase.**

8. Replace panels previously removed.

## P. REPLACEMENT OF HOT GAS VALVE BODY

1. Follow the steps in procedures J to remove the hot gas valve coil.
2. Recover the refrigerant from the system and transfer it in a bottle so to reclaim or recycle it.
3. Unsolder the refrigerant lines from the hot gas valve body and remove it from the unit.

**NOTE.** Always install a replacement drier whenever the sealed refrigeration system is open. Do not replace the drier until all other repairs or replacements have been completed.

4. To install the replacement hot gas valve body follow the above steps in reverse.

**NOTE.** Thoroughly evacuate the system to remove moisture and non condensables after hot gas valve replacement.

## Q. REPLACEMENT OF EVAPORATOR PLATEN

1. Remove top and rear panels.
2. Remove the plastic cover from the upper part of the evaporator platen.
3. Recover the refrigerant from the system and transfer it in a bottle so to reclaim or recycle it.
4. Unsolder and disconnect the capillary tube and hot gas line from one serpentine of evaporator and the suction discharge line from the other serpentine.
5. Lift the evaporator platen assembly out of its seat.

**NOTE.** Always install a replacement drier whenever the sealed refrigeration system is open. Do not replace the drier until all other repairs or replacements have been completed.

6. To install the replacement evaporator follow the above steps in reverse.

**NOTE.** Thoroughly evacuate the system to remove moisture and non condensables after evaporator replacement.

## R. REPLACEMENT OF AIR COOLED CONDENSER

1. Remove front central panels.
2. Remove from the condenser fins the condenser sensor probe as well as the ambient temperature sensor probe.
3. Remove the screws attaching the condenser to the unit frame.

4. Recover the refrigerant from the system and transfer it in a bottle so to reclaim or recycle it.
5. Unsolder the refrigerant lines from the condenser and remove it from the unit.

**NOTE.** Always install a replacement drier whenever the sealed refrigeration system is open. Do not replace the drier until all other repairs or replacements have been completed.

6. To install the replacement condenser follow the above steps in reverse.

**NOTE.** Thoroughly evacuate the system to remove moisture and non condensables after condenser replacement.

### S. REPLACEMENT OF WATER COOLED CONDENSER

1. Remove front central panel.
2. Remove the condenser and the ambient temperature sensor probes from condenser.
3. Remove bolts which secure the condenser to the unit base.
4. Remove the corbin clamps and disconnect the plastic hoses from the water cooled condenser.
5. Recover the refrigerant from the system and transfer it in a container so to reclaim or recycle it.
6. Unsolder the refrigerant lines from the condenser and remove it from the unit.

**NOTE.** Always install a replacement drier whenever the sealed refrigeration system is open. Do not replace, the drier until all other repairs or replacements have been completed.

7. To install the replacement condenser follow the above steps in reverse.

**NOTE.** Thoroughly evacuate the system to remove moisture and non condensables after condenser replacement.

### T. REPLACEMENT OF WATER REGULATING VALVE (WATER COOLED MODELS)

1. Remove the rear central panel.
2. Close the shut-off valve on the water supply line and disconnect it at the rear of the cuber.

3. Remove corbin clamp and disconnect the water hose from the outlet of water regulating valve.

4. Unloose the nut securing the water regulating valve to the unit frame.

5. Recover the refrigerant from the system and transfer it in a container so to reclaim or recycle it.

6. Trace the water regulating valve capillary tube and unsolder its end from the refrigerant line then remove it from the unit.

**NOTE.** Always install a replacement drier whenever the sealed refrigeration system is open. Do not replace the drier until all other repairs or replacements have been completed.

7. To install the replacement evaporator follow the above steps in reverse.

**NOTE.** Thoroughly evacuate the system to remove moisture and non condensables after water regulating valve replacement.

**NOTE.** The water flow that passes through the valve can be adjusted by means of the valve setting stem.

### U. REPLACEMENT OF COMPRESSOR

1. Remove the front center panel as well as the rear one.
2. Unloose the screws securing the air cooled condenser to unit frame and open it to gain access to the compressor compartment.
3. Remove the cover and disconnect the electrical leads from the compressor junction box.
4. Recover the refrigerant from the system and transfer it in a bottle so to reclaim or recycle it.
5. Unsolder and disconnect both the suction line and the discharge line from the compressor.
6. Remove the four compressor mounting bolts and the compressor from the unit base.

**NOTE.** Always install a replacement drier whenever the sealed refrigeration system is open. Do not replace the drier until all other repairs or replacements have been completed.

7. To install the replacement compressor follow the above steps in reverse.

**NOTE.** Thoroughly evacuate the system to remove moisture and non condensables after compressor replacement.

## LIQUID CHARGING

Because R-404 is a near-azeotrope, only liquid refrigerant can be used to recharge the refrigeration system. To do that may take some special techniques:

1. Use an electronic scale to measure the charge.
2. Place a drum or cylinder of R-404A on the scale, valves side up (R-404A disposable cylinders have an internal dip tube and dispense liquid refrigerant from the valve when it is upright).
3. A refrigeration manifold should be attached to the service access valves. Attach the charging hose to the cylinder of R-404A. Open the cylinder's valve and purge the hose to the manifold.
4. Open the discharge side manifold valve and weigh in the name plate charge. After the charge is weighed in, wait a few minutes and recheck the scale.
5. If all of the refrigerant charge has not been weighed into the discharge side, it must be carefully added thru the low side. Close the discharge side manifold valve.
6. With a sight glass or charge faster in the hose to the low side port, start the ice machine.
7. Crack open the low side manifold valve and watch the scale and sight glass. Open and close the low side manifold valve to flow liquid into the manifold but flash off to vapor before it enters the suction side of the refrigerant system. This should only be a few ounces at most.
8. After the scale = the correct charge, shut off the valve on the refrigerant cylinder.
9. Remove the refrigerant manifold gages.
10. Replace and tighten all caps.

# WIRING DIAGRAM

## AIR AND WATER COOLED 400/50/3 + N

- B - WHITE
- G - GREY
- N - BLACK
- A - BLUE
- M - BROWN
- GV - YELLOW GREEN

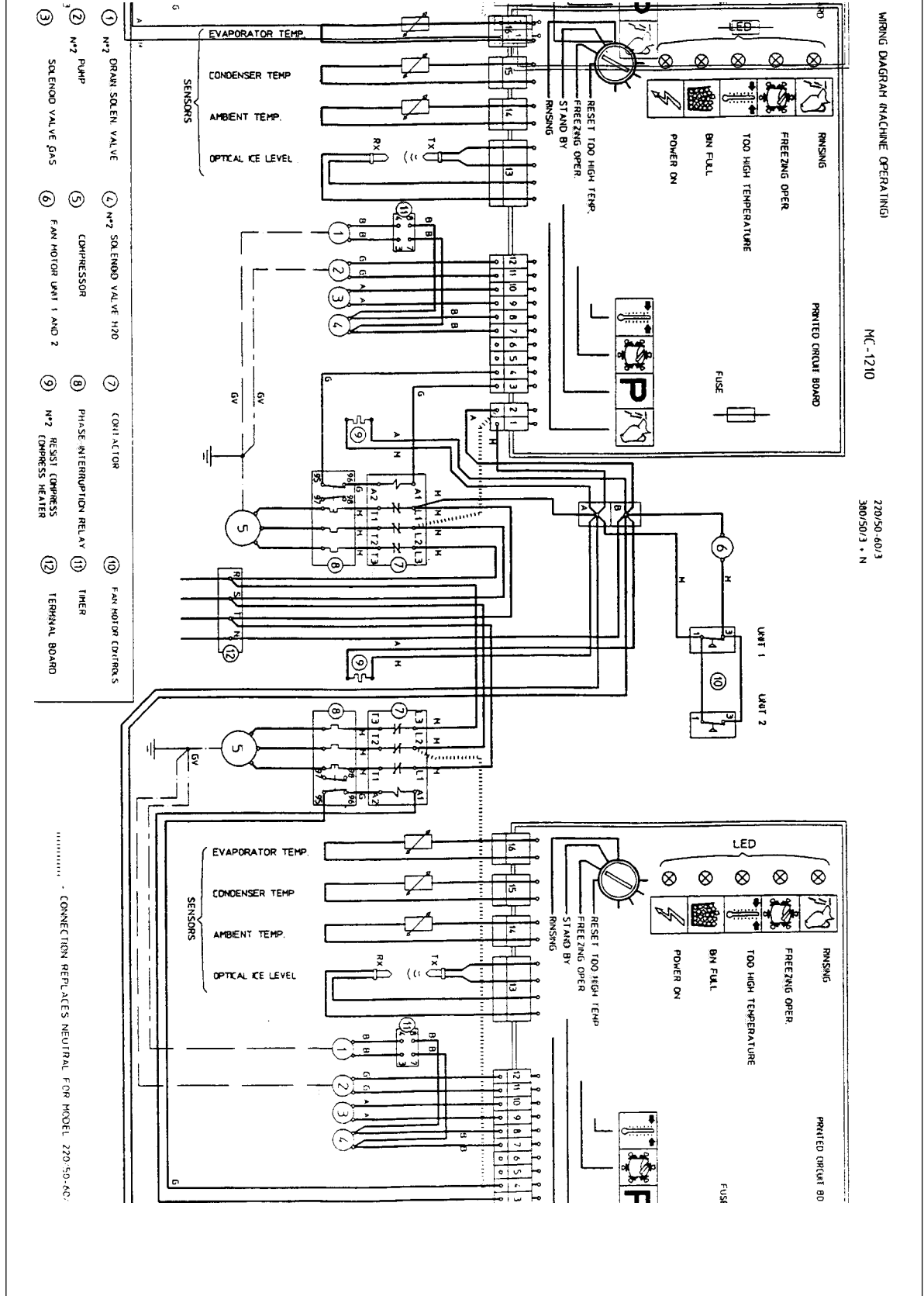

**SERVICE DIAGNOSIS**

<b>SYMPTON</b>	<b>POSSIBLE CAUSE</b>	<b>SUGGEST CORRECTION</b>
Unit will not run (No warning LEDS glows)	Blown fuse in P.C. Board	Replace fuse & check for cause of blown fuse
	Incorrect contact of fuse in P.C.B.	Check grip of the fuse holders
	Main switch in OFF position	Turn switch to ON position
	Inoperative P.C. Board	Replace P.C. Board
	Loose electrical connections	Check wiring/Connector
(Green LED-Power ON glows)	P.C. Board selector in STAND BY	Move to OPERATING position
(Bin full LED glows)	Inoperative ice level control	Replace ice level control
(Red-alarm LED glows)	High head pressure	Dirty condenser. Clean Inoperative fan motor. Replace
(Red-alarm LED blinks)	Too high evaporating temperature	Check for shortage of refrigerant or for leaking of hot gas valve
Compressor cycles intermittently	Low voltage	Check circuit for overloading Check voltage at the supply to the building. If low, contact the power company
	Contactors with burnt contacts	Clean or replace
	Non-condensable gas in system	Purge the system
	Compressor starting device with	Check for loose wires in starting loose wires device
Cubes too small	Freezing cycle too short	Review setting of DIP SWITCH keys
	Capillary tube partially restricted	recover refig. add new gas & drier, after evacuating the system
	Moisture in the system	Same as above
	Shortage of water	See remedies for shortage of water
	Shortage of refrigerant	Check for leaks & recharge
	Inoperative evaporator sensor	Replace sensor
Cloudy cubes	Shortage of water	See remedies for shortage of water
	Dirty water supply	use water softner or water filter
	Accumulated impurities	Use SCOTSMAN Ice Machine cleaner
	Spray bar not rotating	remove spray bar & jet bearing and clean them
Shortage of water	Water solenoid valve not opening	Replace valve
	Water leak in sump area	Locate and repair
	Water flow control plugged	Remove and clean
	Too lo water inlet pressure	Min. water inlet pressure must be 1 bar

**SERVICE DIAGNOSIS**

<b>SYMPTON</b>	<b>POSSIBLE CAUSE</b>	<b>SUGGEST CORRECTION</b>
Irregular cubes size & some cloudy	Some jets plugged	remove spray bar & jet bearing and clean them
	Shortage of water	See shortage of water
	Unit not level	Level as required
	Spray bar not rotating	Remove spray bar & jet bearing and clean them
Cubes too large	Freezing cycle too long	Review setting of DIP SWITCH keys
Decrease ice capacity	Inefficient compressor	Replace
	Leaky water valve	repair or replace
	Non-condensable gas in system	Recover refrig. add new gas & drier, after evacuating the system
	Poor air circulation or excessive hot location (Red-alarm LED glows)	Relocate the unit or provide for more ventilation
	Overcharge of refrigerant	Correct the charge. Purge off slowly
	Capillary tube partially restricted	Recover refrig. add new gas & drier, after evacuating the system
	Hot gas solenoid valve leaking	Replace valve
	Undercharge of refrigerant	Charge to data plate indication
	Spray bar not rotating	Remove spray bar & jet bearing and clean them
Discharge head pressure too high	See incorrect discharge pressure	
Poor harvest	Too short defrost time	Check & adjust DIP SWITCH keys 5-6-7
	Restriction in incoming water line	Check water valve strainer and flow control. If necessary enlarge the flow control orifice
	Water inlet valve not opening	Valve coil with open winding Replace valve
	Hot gas valve orifice restricted	Replace hot gas valve assy
	Air vented holes in mold cups plugged	Clean out holes
Discharge head pressure too low	See incorrect discharge pressure	
Unit won't harvest	Inoperative P.C. Board	Replace P.C. Board
	Hot gas valve not opening	Valve coil with open winding Replace valve
	Water solenoid valve not opening	Valve coil with open winding Replace valve
Incorrect discharge pressure	inoperative condenser sensor	Replace sensor
	Inoperative P.C. Board	Replace P.C. Board
	Water regulating valve misadjusted	Adjust its setting stem
Excessive water in unit base	Water tubing leaking	Check. Tighten or replace.

## MAINTENANCE AND CLEANING INSTRUCTIONS

### A. GENERAL

The periods and the procedures for maintenance and cleaning are given as guides and are not to be construed as absolute or invariable.

Cleaning, especially, will vary depending upon local water and ambient conditions and the ice volume produced; and, each icemaker must be maintained individually, in accordance with its particular location requirements.

### B. ICEMAKER

The following maintenance should be scheduled at least two times per year on these icemakers.

1. Check and clean the water line strainer.
2. Check that the icemaker is levelled in side to side and in front to rear directions.
3. Clean the water system, evaporators, bin and spray bar/s using a solution of SCOTSMAN Ice Machine Cleaner. Refer to procedure C cleaning instructions and after cleaning will indicate frequency and procedure to be followed in local areas.
4. Reach the water spray bar from the inside of the freezing chamber lifting it from its seat with its bottom race washer.

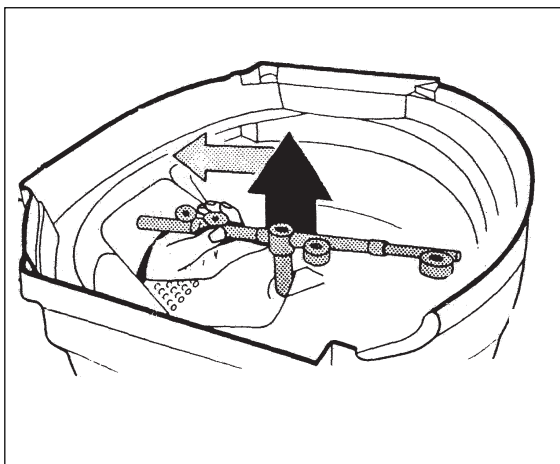

Dip it into a tray filled with cleaning solution then rinse it under a tap water stream.

With a pick clean the orifice of the water stream jet that propells the spray bar.

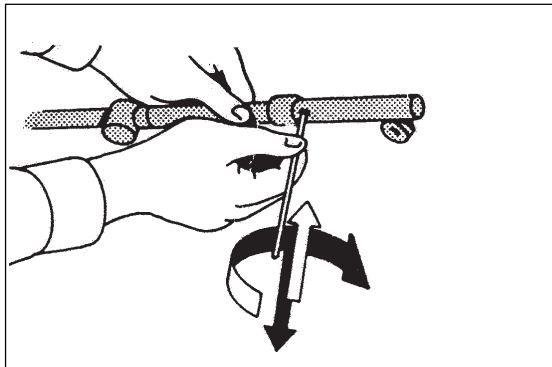

**NOTE.** *Cleaning requirements vary according to the local water conditions and individual user operation. Continuous check of the clarity of ice cubes and visual inspection of the water spraying parts before and after cleaning will indicate frequency and procedure to be followed in local areas.*

5. With the ice machine and fan motor OFF on air cooled models, clean condenser using vacuum cleaner, whisk broom or non metallic brush taking care to do not damage both the condenser and ambient temperature sensor probes.
6. Check for water leaks and tighten drain line connections. Pour water down through the storage bin drain line to be sure that drain line is open and clear.
7. Check size, condition and texture of ice cubes. Perform adjustment of DIP SWITCH keys as required.
8. Check the ice level control sensor to test shut-off. Put your hand between the light source and the receiver so to cut off the light beam for at least one minutes. This should cause the ice maker to shut off and the light-up of the 2nd LED (yellow light).

**IMPORTANT.** *Perform the above check only at the end of harvest cycle or at the beginning of freezing cycle in order to do not cause to the unit to make a double freezing cycle.*

**NOTE.** *Within few seconds after the removal of the hand from the Infrared sensing light the icemaker restarts in **freezing cycle**. The ice level control uses devices that sense light, therefore they must be kept clean enough so they can "see". Every month clean/wipe the sensing "eyes" with a clean soft cloth.*

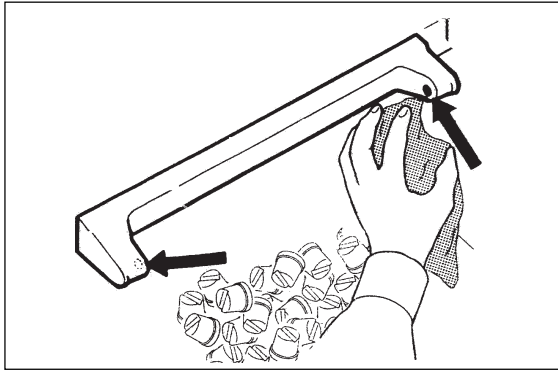

two or three liters of warm water (45°-50°C) with a 0,2-0,3 liters of **SCOTSMAN** Ice Machine Cleaner.

**WARNING.** The SCOTSMAN Ice Machine Cleaner contains Phosphoric and Hydroxyacetic acids. These compounds are corrosive and may cause burns if swallowed, DO NOT induce vomiting. Give large amounts of water or milk. Call Physician immediately. In case of external contact flush with water. KEEP OUT OF THE REACH OF CHILDREN

9. Check for refrigerant leaks.

**C. CLEANING INSTRUCTIONS OF WATER SYSTEM**

1. Remove left, center and right front panels to gain access either to the control box and to the evaporator.
2. Wait till the end of defrost cycle then, with the help of a normal screw driver, turn the program selector head on **STAND BY** position to temporarily stop the operation (Fig.7).
3. Prepare for each freezing chamber the cleaning solution by diluting in a plastic container

4. Scoop out all the ice cubes stored into the bin in order to prevent them from being contaminated with the cleaning solution then flush out the water from the sump reservoir by bending down the vertical sump drain hose.
5. Remove the evaporator cover then slowly pour onto the evaporator piaten the cleaning solution- With the help of a brush dissolve the most resistant and remote scale deposits in the platen. Perform the same for all the four evaporators.
6. Set the program selector head on **CLEANING**. The 5th **YELLOW LED** lights-up (Fig.8).

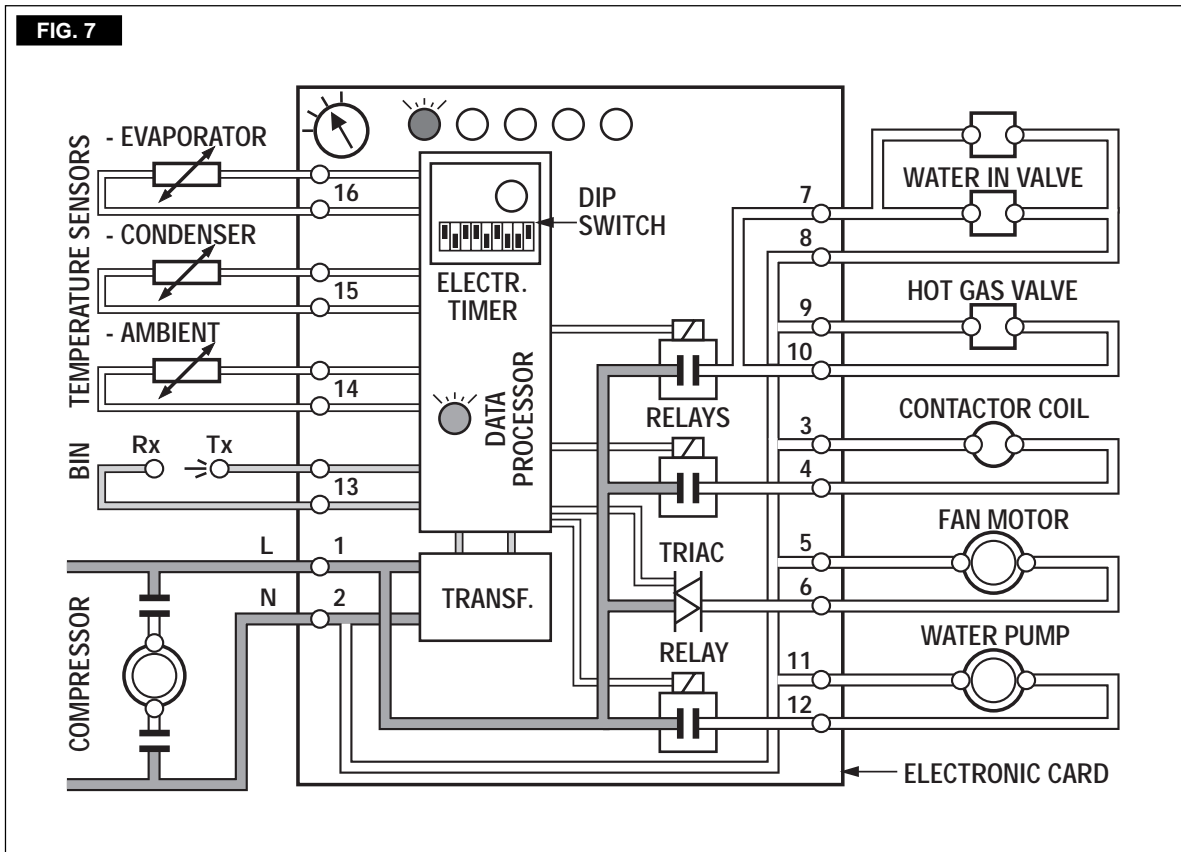

**NOTE.** With the system in **CLEANING** mode the water pump is the only component in operation to circulate the cleaning solution in the entire water system.

7. Let the unit to remain in the **CLEANING** mode for about 20 minutes then turn the program selector on **STAND BY** again.

8. Flush out the cleaning solution from the sump reservoir then pour onto the evaporator cavity two or three liters of clean potable water with a capfull of antibacteria solution to rinse and sanitize the mold cups and the platen. If necessary remove the water spray bar to clean it separately as per steps 3 and 4 of paragraph B.

9. Turn again the program selector on **CLEANING**. The water pump is again in operation to circulate the water and the antibacterial solution in order to rinse the entire water system.

10. Flush out the rinsing water from the sump reservoir then turn the program selector on **RESET/HI TEMPERATURE** position and immediately afterward to **FREEZING OPERATION**.

**NOTE.** By setting the selector on **RE-SET** first and then to **FREEZING OPERATION** the ice maker will perform the 5 minutes **WATER FILLING** phase i.e. the water inlet solenoid valve opens to allow the incoming water to rinse again the water system and to properly fill-up the sump reservoir for the next freezing cycle.

11. Place again the evaporator cover and the unit service panels.

12. At completion of the freezing and harvest cycle make sure of proper texture and clearness of the ice cubes and that, they do not have any acid taste.

**ATTENTION.** in case the ice cubes are cloudy, white and have an acid taste, melt them immediately by pouring on them some warm water. This to prevent that somebody could use them.

16. Wipe clean and rinse the inner surfaces of the storage bin.

**REMEMBER.** To prevent the accumulation of undesirable bacteria it is necessary to sanitize the interior of the storage bin with an anti-algae disinfectant solution every week.

