



SERVICE MANUAL

EC 106

EC 126

EC 176

**Electronic cubers
with storage**

INDICE

Table of contents	page	2
Specifications EC 106		3
Specifications EC 126		5
Specifications EC 176		7
 GENERAL INFORMATION AND INSTALLATION		
Introduction		9
Unpacking and Inspection		9
Location and levelling		9
Electrical connections		9
Water supply and drain connections		10
Final check list		10
Installation practice		11
 OPERATING INSTRUCTIONS		
Start up		12
Operational checks		13
 OPERATING PRINCIPLES (How it works)		
Freezing cycle		17
Harvest cycle		21
Electrical sequence		24
Components description		25
 ADJUSTMENT, REMOVAL AND REPLACEMENT PROCEDURES		
Adjustment of the cube size		30
Wiring diagram EC 106		31
Wiring diagram EC 126 - EC 176		32
Service diagnosis		33
 MAINTENANCE AND CLEANING INSTRUCTIONS		
General		36
Icemaker		36
Clean - Replace of air condenser filter		36
Cleaning instructions of water system		37

SPECIFICATIONS

ELECTRONIC CUBER MODEL EC 106

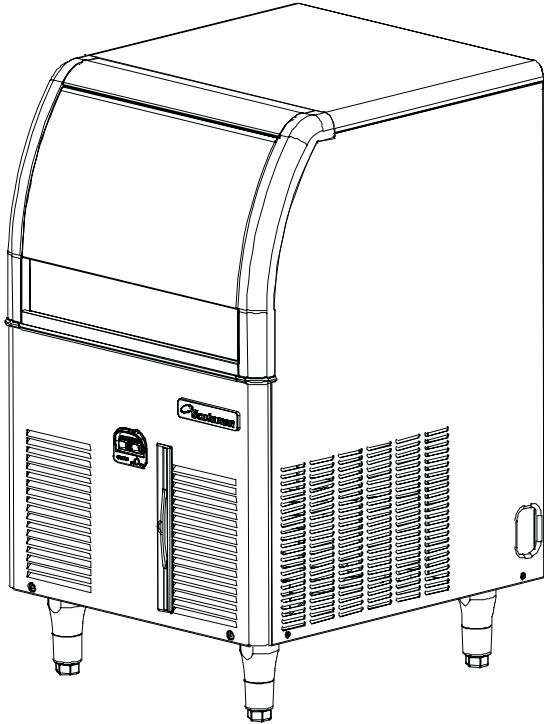

Important operating requirements:

	MIN.	MAX.
Air temperature	10°C	40°C
Water temperature	5°C	35°C
Water pressure	1 bar	5 bar
Electr. voltage variations from voltage rating specified on nameplate	-10%	+10%

ice making capacity

AIR COOLED MODELS

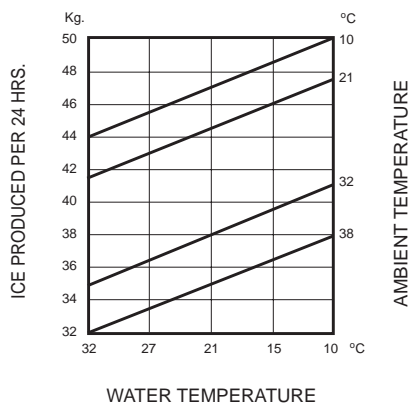

WATER COOLED MODELS

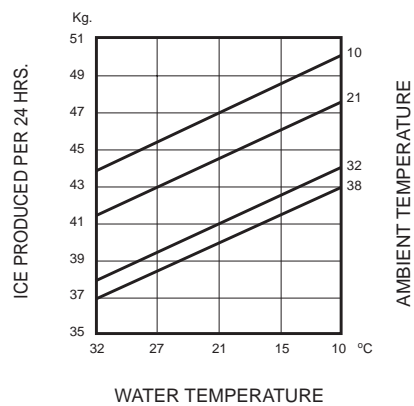

NOTE. With the unit in "built-in" conditions, the ice production is gradually reduced in respect to the levels shown in the graf, up to a maximum of 10% at room temperatures higher than 32° C. The daily ice-making capacity is directly related to the condenser air inlet temperature, water temperature conditions of the condenser air filter and age of the machine. To keep your SCOTSMAN CUBER at peak performance levels, periodic maintenance checks must be carried out as indicated on Maintenance and Cleaning section of this manual.

SPECIFICATIONS

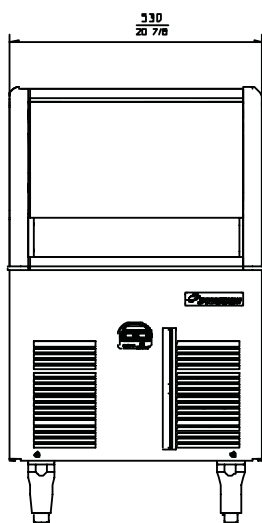
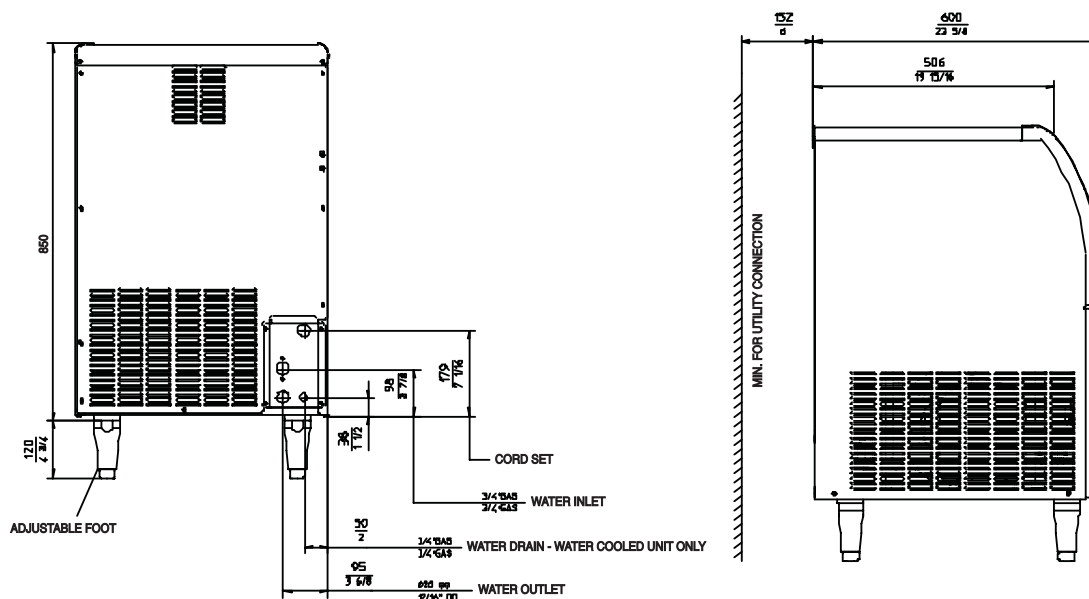

Dimensions:

- HEIGHT (without legs) 850 mm.
- HEIGHT (with legs) 970 mm.
- WIDTH 530 mm.
- DEPTH 600 mm.
- WEIGHT Kgs.

EC 106 - CUBER machine specifications

Model	Cond. unit	Finish	Comp. HP	Bin Capacity	Water req. lt/24 HR	
EC 106 AS 6 EC 106 WS 6	Air Water	Stainless steel	3/8	23 Kg.	136 550*	
Basic electr.	Amps	Start Amps	Watts	Electric power cons. Kwh per 24 Hr	Nr. of wires	Amps fuse
230/50/1	3.3	18	550	10.3	3 x 1.5 mm ²	10
				9.4		
Cubes per harvest: 32 medium * A 15°C water temperature						

SPECIFICATIONS

ELECTRONIC CUBER MODEL EC 126

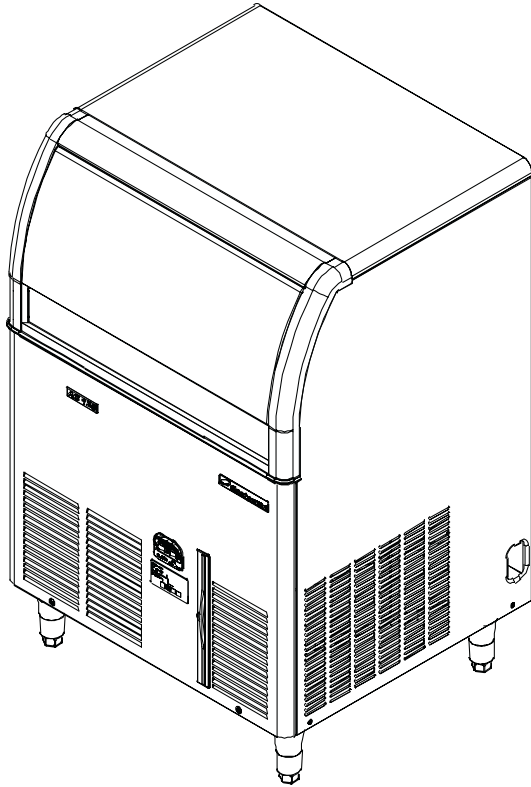

Important operating requirements:

	MIN.	MAX.
Air temperature	10°C	40°C
Water temperature	5°C	35°C
Water pressure	1 bar	5 bar
Electr. voltage variations from voltage rating specified on nameplate	-10%	+10%

ice making capacity

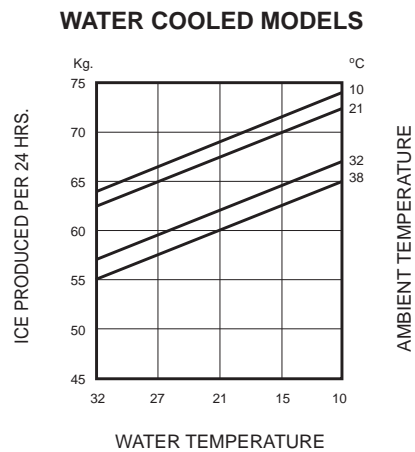
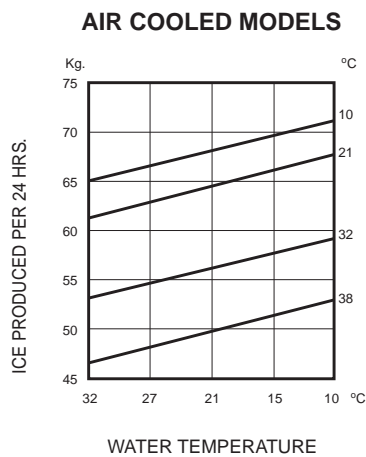

NOTE. With the unit in "built-in" conditions, the ice production is gradually reduced in respect to the levels shown in the graf, up to a maximum of 10% at room temperatures higher than 32° C. The daily ice-making capacity is directly related to the condenser air inlet temperature, water temperature conditions of the condenser air filter and age of the machine. To keep your SCOTSMAN CUBER at peak performance levels, periodic maintenance checks must be carried out as indicated on Maintenance and Cleaning section of this manual.

SPECIFICATIONS

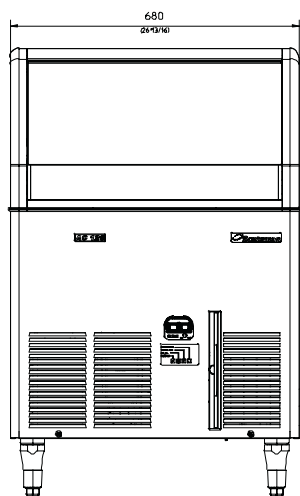
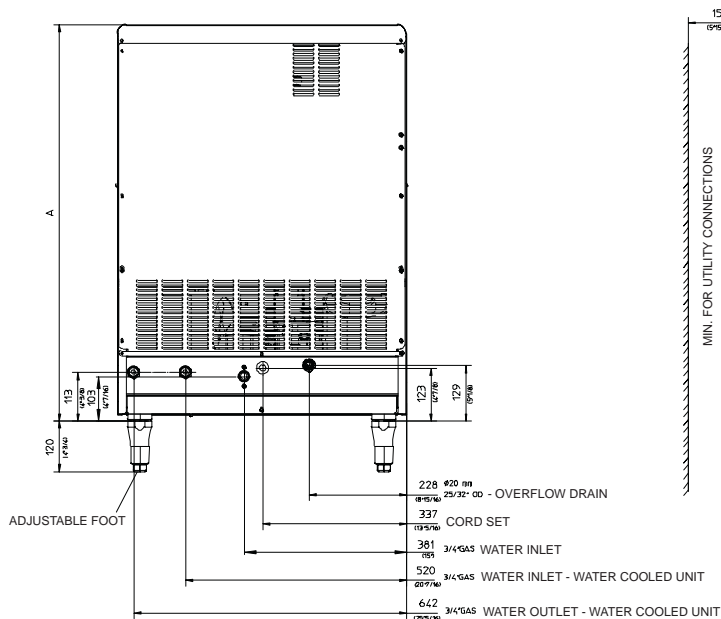

Dimensions:

- HEIGHT (without legs) 930 mm.
- HEIGHT (with legs) 1050 mm.
- WIDTH 680 mm.
- DEPTH 600 mm.
- WEIGHT 75 Kgs.

EC 126 - CUBER machine specifications

Model	Cond. unit	Finish	Comp. HP	Bin Capacity	Water req. lt/24 HR	
EC 126 AS 6 EC 126 WS 6	Air Water	Stainless steel	1/2	39 Kg.	190 750*	
Basic electr.	Amps	Start Amps	Watts	Electric power cons. Kwh per 24 Hr	Nr. of wires	Amps fuse
230/50/1	4	19	600	14	3 x 1.5 mm ²	10
				11.8		
Cubes per harvest: 48 medium * A 15°C water temperature						

SPECIFICATIONS

ELECTRONIC CUBER MODEL EC 176

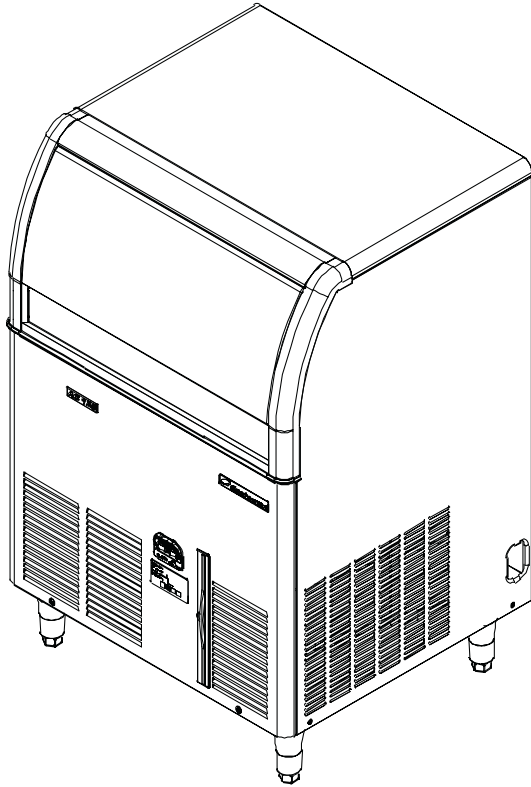

Important operating requirements:

	MIN.	MAX.
Air temperature	10°C	40°C
Water temperature	5°C	35°C
Water pressure	1 bar	5 bar
Electr. voltage variations from voltage rating specified on nameplate	-10%	+10%

ice making capacity

AIR COOLED MODELS

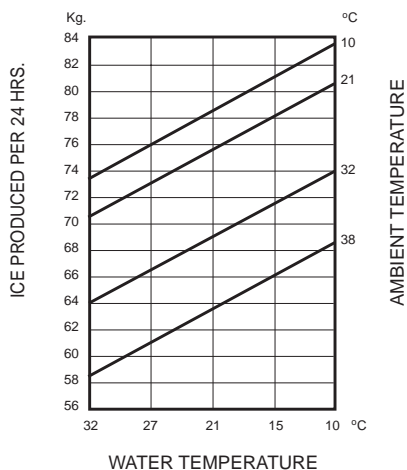

WATER COOLED MODELS

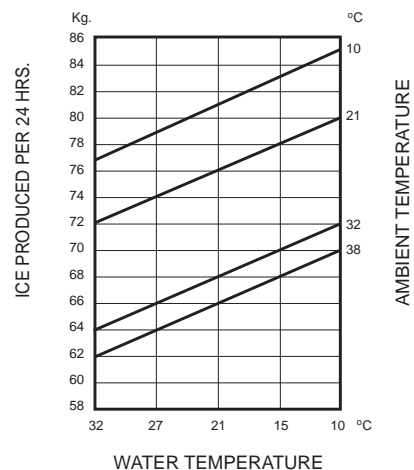

NOTE. With the unit in "built-in" conditions, the ice production is gradually reduced in respect to the levels shown in the graf, up to a maximum of 10% at room temperatures higher than 32°C. The daily ice-making capacity is directly related to the condenser air inlet temperature, water temperature conditions of the condenser air filter and age of the machine. To keep your SCOTSMAN CUBER at peak performance levels, periodic maintenance checks must be carried out as indicated on Maintenance and Cleaning section of this manual.

SPECIFICATIONS

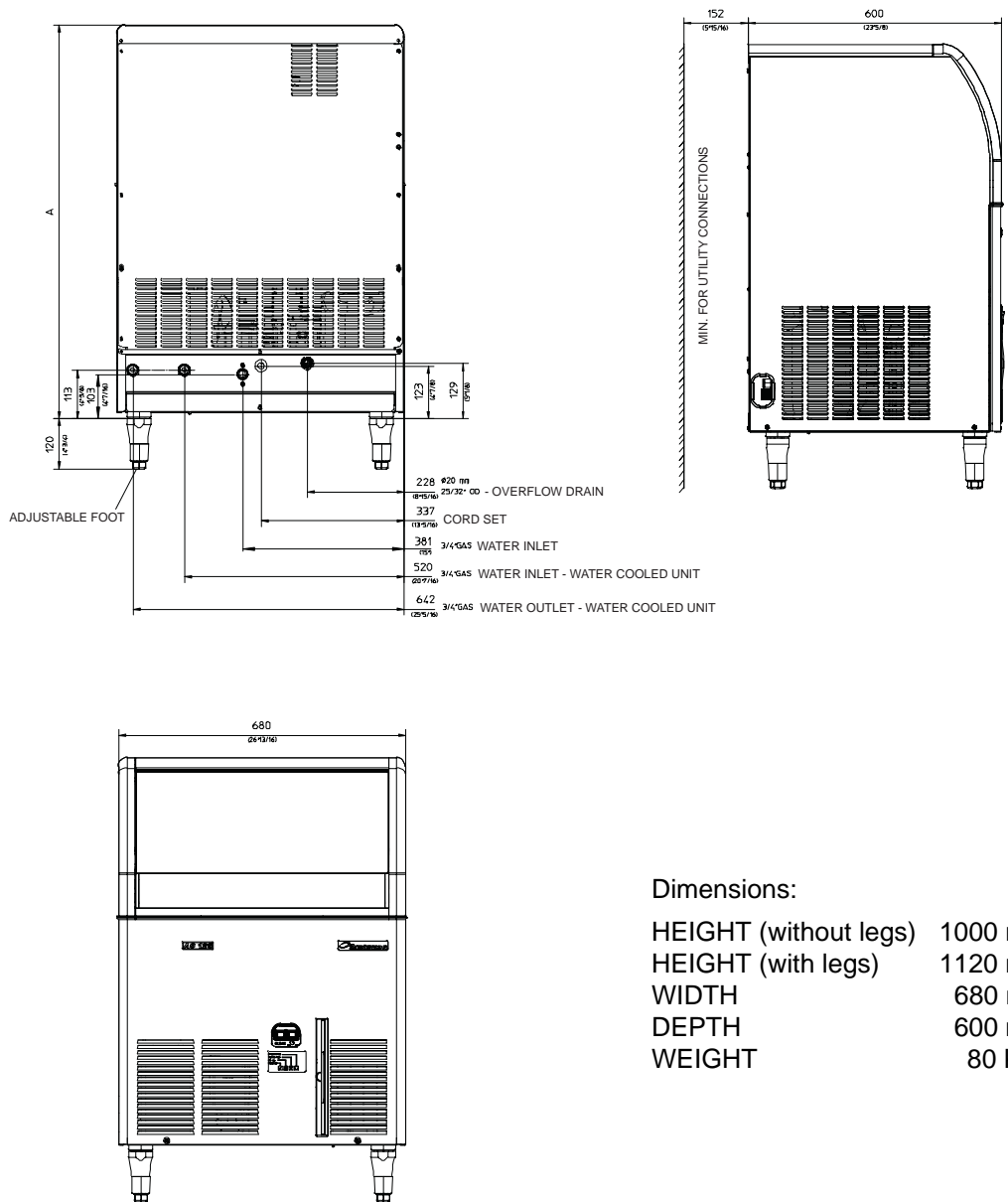

Dimensions:
 HEIGHT (without legs) 1000 mm.
 HEIGHT (with legs) 1120 mm.
 WIDTH 680 mm.
 DEPTH 600 mm.
 WEIGHT 80 Kgs.

EC 176 - CUBER machine specifications

Model	Cond. unit	Finish	Comp. HP	Bin Capacity	Water req. lt/24 HR	
EC 176 AS 6 EC 176 WS 6	Air Water	Stainless steel	3/4	48 Kg.	150 1050*	
Basic electr.	Amps	Start Amps	Watts	Electric power cons. Kwh per 24 Hr	Nr. of wires	Amps fuse
230/50/1	5.6	26	760	15	3 x 1.5 mm ²	10
				13.5		
Cubes per harvest: 48 medium * A 15°C water temperature						

GENERAL INFORMATION AND INSTALLATION

A. INTRODUCTION

This manual provides the specifications and the step-by-step procedures for the installation, start-up and operation, maintenance and cleaning for the SCOTSMAN EC series icemakers.

These Cubers are quality designed, engineered and manufactured.

Their ice making systems are thoroughly tested providing the utmost in flexibility to fit the needs of a particular user.

These icemakers have been engineered to our own rigid safety and performance standards.

NOTE. *To retain the safety and performance built into this icemaker, it is important that installation and maintenance be conducted in the manner outlined in this manual.*

B. UNPACKING AND INSPECTION

1. Call your authorized SCOTSMAN Distributor or Dealer for proper installation.

2. Visually inspect the exterior of the packing and skid. Any severe damage noted should be reported to the delivering carrier and a concealed damage claim form filled in subject to inspection of the contents with the carrier's representative present.

3. a) Cut and remove the plastic strip securing the carton box to the skid.

b) Cut open the top of the carton and remove the polystyrene protection sheet.

c) Pull out the polystyrene posts from the corners and then remove the carton.

4. Remove the front panel of the unit and inspect for any concealed damage. Notify carrier of your claim for the concealed damage as stated in step 2 above.

5. Check that refrigerant lines do not rub against or touch other lines or surfaces, and that the fan blade moves freely.

6. Check that the compressor fits snugly onto all its mounting pads.

7. Remove all internal support packing and masking tape.



8. Use clean damp cloth to wipe the surfaces inside the storage bin and the outside of the cabinet.

9. See data plate on the rear side of the unit and check that local main voltage corresponds with the voltage specified on it.

CAUTION. **Incorrect voltage supplied to the icemaker will void your parts replacement program.**

10. Remove the manufacturer's registration card from the inside of the User Manual and fill-in all parts including: Model and Serial Number taken from the data plate.

Forward the completed self-addressed registration card to Frimont factory.

11. If necessary, replace the four standard legs with the taller ones supplied in the machine and adjust them to level the unit.

C. LOCATION AND LEVELLING

WARNING. **This Ice Cuber is designed for indoor installation only. Extended periods of operation at temperatures exceeding the following limitations will constitute misuse under the terms of the SCOTSMAN Manufacturer's Limited Warranty resulting in LOSS of warranty coverage.**

1. Position the unit in the selected permanent location.

Criteria for selection of location include:

a) Minimum room temperature 10°C (50°F) and maximum room temperature 40°C (100°F).

b) Water inlet temperatures: minimum 5°C (40°F) and maximum 35°C (90°F).

c) Well ventilated location for air cooled models.

d) Service access: adequate space must be left for all service connections through the rear of the ice maker. A minimum clearance of 15 cm (6") must be left at the sides of the unit for routing cooling air drawn into and exhausted out of the compartment to maintain proper condensing operation of air cooled models.

2. Level the unit in both the left to right and front to rear directions.

D. ELECTRICAL CONNECTIONS

See data plate for current requirements to determine wire size to be used for electrical connections. All SCOTSMAN icemakers require a solid earth wire.

All SCOTSMAN ice machines are supplied from the factory completely pre-wired and require only electrical power connections to the wire cord provided at rear of the unit.

Make sure that the ice machine is connected to its own circuit and individually fused (see data plate for fuse size).

The maximum allowable voltage variation should not exceed -10% and + 10% of the data plate rating. Low voltage can cause faulty functioning and may be responsible for serious damage to the overload switch and motor windings.

NOTE. All external wiring should conform to national, state and local standards and regulations.

Check voltage on the line and the ice maker's data plate before connecting the unit.

E. WATER SUPPLY AND DRAIN CONNECTIONS

GENERAL

When choosing the water supply for the ice cuber consideration should be given to:

- Length of run
- Water clarity and purity
- Adequate water supply pressure

Since water is the most important single ingredient in producing ice you cannot emphasize too much the three items listed above.

Low water pressure, below 1 bar may cause malfunction of the ice maker unit.

Water containing excessive minerals will tend to produce cloudy coloured ice cubes, plus scale build-up on parts of the water system.

WATER SUPPLY

Air Cooled Versions

Connect the 3/4" male fitting of the solenoid water inlet valve, using the flexible tube supplied, to the cold water supply line with regular plumbing fitting and a shut-off valve installed in an accessible position between the water supply line and the unit.

If water contains a high level of impurities, it is advisable to consider the use an appropriate water filter or conditioner.

EC 106 - Water Cooled Version

On Water Cooled version the water inlet solenoid valve has two separate outlets one for the condenser and the second for the production of ice.

EC 126-176 - Water Cooled Versions

The water cooled versions of SCOTSMAN Ice Makers require two separate inlet water supplies, one for water sprayed for making the ice cubes and the other for the water cooled condenser. Connect the 3/4" male fitting of the water inlet,

using the flexible tube supplied to the cold water supply line with regular plumbing fitting and a shut-off valve installed in an accessible position between the water supply line and the unit.

WATER DRAIN

The recommended drain tube is a plastic or flexible tube with 18 mm (3/4") I.D. which runs to an open trapped and vented drain.

WATER DRAIN - WATER COOLED MODELS

Connect the 3/4" male fitting of the condenser water drain, utilizing a second flexible hose, to the open trapped and vented drain.

NOTE. The water supply and the water drain must be installed to conform with the local code. In some case a licensed plumber and/ or a plumbing permit is required.

The EC series Ice Cubers can pump out water up to 1.5 m rise

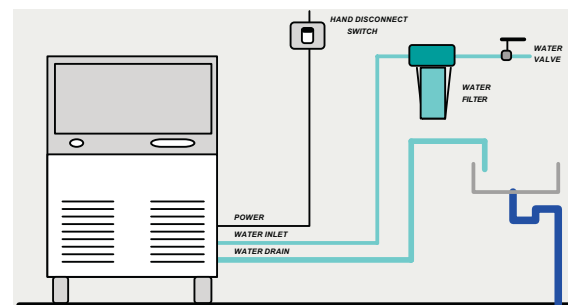

or to 30 m on horizontal length.

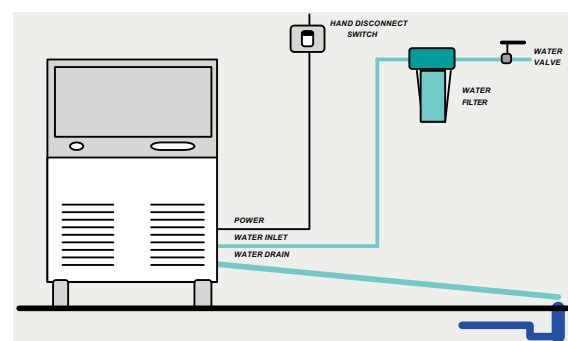

F. FINAL CHECK LIST

- Is the unit in a room where ambient temperatures are within a minimum of 10°C (50°F) even in winter months?
- Is there at least a 15 cm (6") clearance around the unit for proper air circulation?

3. Is the unit level? (IMPORTANT)
4. Have all the electrical and plumbing connections been made, and is the water supply shut-off valve open?
5. Has the voltage been tested and checked against the data plate rating?
6. Has the water supply pressure been checked to ensure a water pressure of at least 1 bar (14 psi).
7. Check all refrigerant lines and conduit lines to guard against vibrations and possible failure.
8. Have the bolts holding the compressor down been checked to ensure that the compressor is snugly fitted onto the mounting pads?
9. Have the bin liner and cabinet been wiped clean?
10. Has the owner/user been given the User Manual and been instructed on the importance of periodic maintenance checks?
11. Has the Manufacturer's registration card been filled in properly? Check for correct model and serial number against the serial plate and mail the registration card to the factory.
12. Has the owner been given the name and the phone number of the authorized SCOTSMAN Service Agency serving him?

G. INSTALLATION PRACTICE

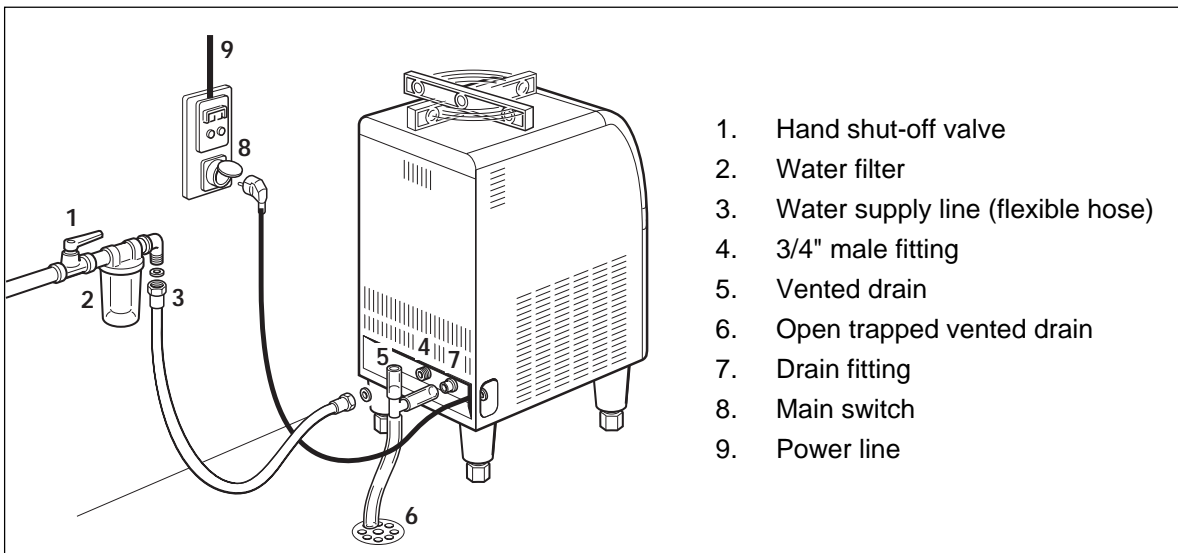

WARNING. This icemaker is not designed for outdoor installation and will not function in ambient temperatures below 10°C (50°F) or above 40°C (100°F). This icemaker will malfunction with water temperatures below 5°C (40°F) or above 35°C (90°F).

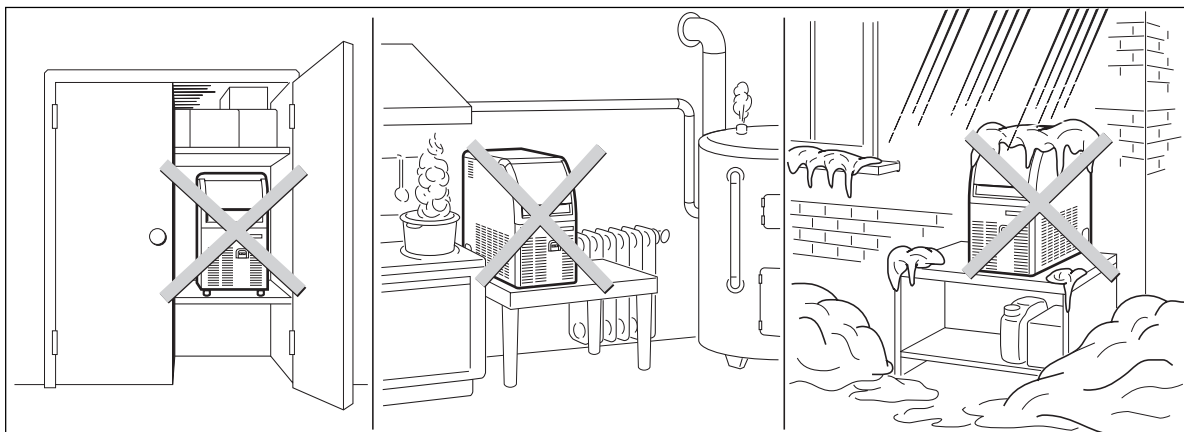

OPERATING INSTRUCTIONS

START UP

After having correctly installed the ice maker and completed the plumbing and electrical connections, perform the following "Start-up" procedure.

- A.** Switch ON the power line disconnect switch and push the green button switch. Unit will start up in charging cycle mode.

NOTE. Every time the unit returns under power, after having been switched off, the water inlet valve, the hot gas valve and the water drain valve get energized for a period of 5 minutes, thus to admit new water to the machine sump reservoir to fill it up and, eventually, to wash-off any dirt that can have deposited in it during the unit off period (Fig.1).

- B.** During the water filling operation, check to see that the incoming water dribbles, through the evaporator platen dribbler holes, down into the

sump reservoir to fill it up and also that the incoming surplus of water flows out through the overflow pipe into the drain line.

During the water filling phase the components energized are:

- THE WATER INLET SOLENOID VALVE**
- THE HOT GAS SOLENOID VALVE**
- THE WATER DRAIN SOLENOID VALVE** (On EC 126 and EC 176 only).

NOTE. If in the 5 minutes length of the water filling phase the machine sump reservoir does not get filled with water up to the rim of the overflow pipe, it is advisable to check:

1. The water pressure of the water supply line that must be at least **1 bar (14 psig)** Minimum (Max 5 bar-70 psig).
2. The filtering device installed in the water line that may reduce the water pressure below the Minimum value of 1 bar (14 psig).
3. Any clogging situation in the water circuit like the inlet water strainer and/or the flow control.

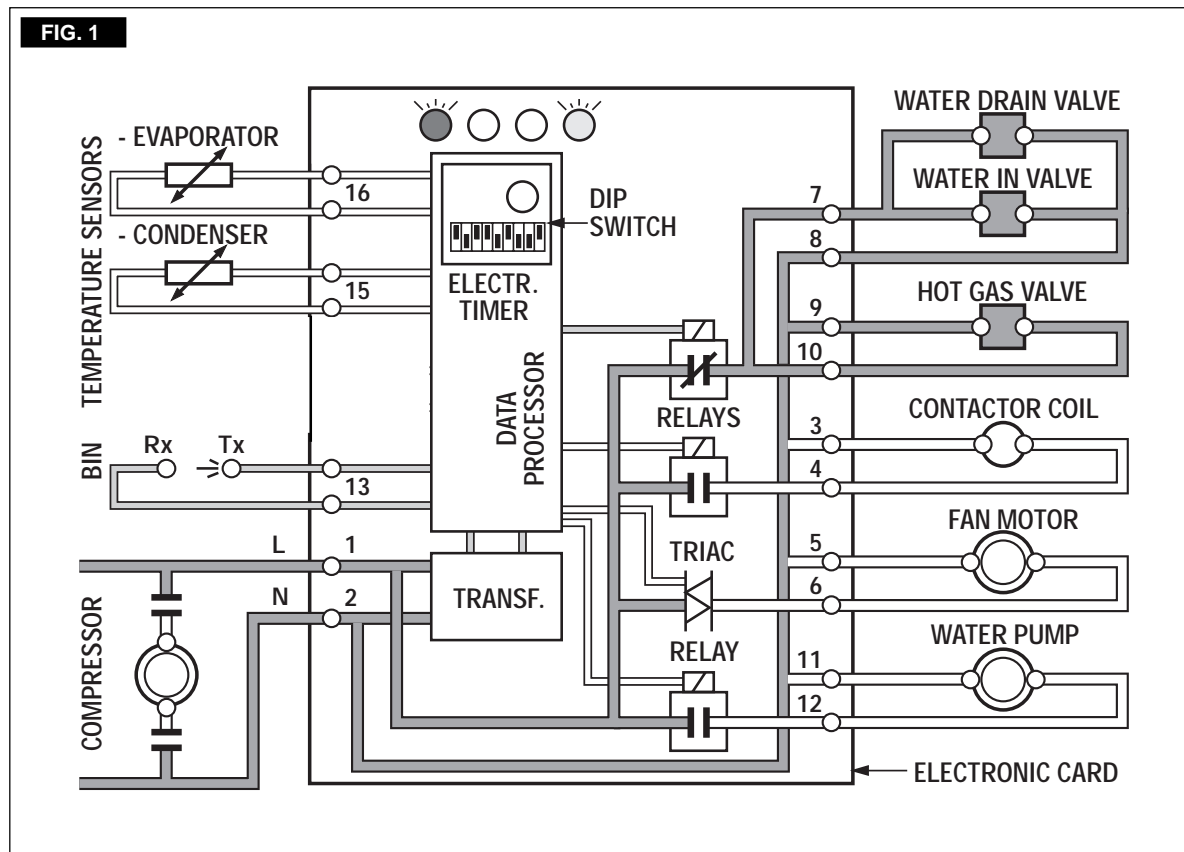

C. At completion of the water filling phase (5 minutes) the unit passes automatically into the freezing cycle with the start up of:

COMPRESSOR

CONTACTOR COIL (EC 126-176 only)

WATER PUMP

FAN MOTOR (in air cooled version) controlled by the condensing temperature sensor located within the condenser fins (Fig.2).

OPERATIONAL CHECKS

D. Install, if required, the refrigerant service gauges on both the high side and low side Scraeder valves to check the compressor head and suction pressures.

NOTE. On air cooled models, the condenser temperature sensor, which is located within the condenser fins, keep the head (condensing) pressure between 8.5 and 9.5 bar (110÷130 psig).

In case of air condenser filter clogged such to prevent the proper flow of the cooling air or, in case the fan motor is out of operation or shortage of water in the water cooled condenser, the condenser temperature rises and when it reaches 70°C (160°F) - for air cooled version - or 60°C (140°F) - for water cooled version - the condenser temperature sensor shuts-off the ice maker with the consequent light-up of the RED WARNING LED (Fig.3) as well as the Red Alarm Light (ON Steady).



After having diagnosed the reason of the rise of temperature and removed its cause, it is necessary to Switch OFF (wait few seconds) and Switch ON the unit, thus to put the machine in condition to initiate a new freezing cycle.

The machine restarts with the usual 5 minutes water filling phase in order to provide enough water into the sump tank.

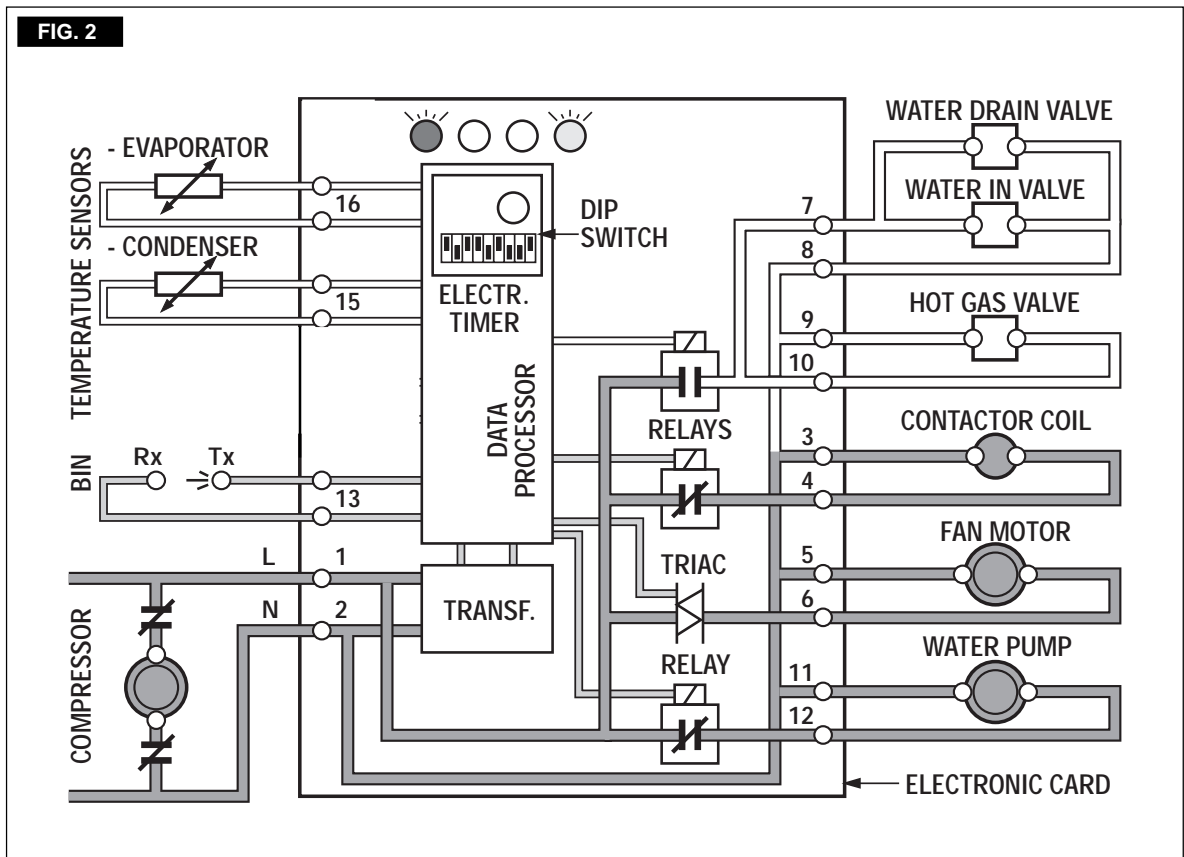

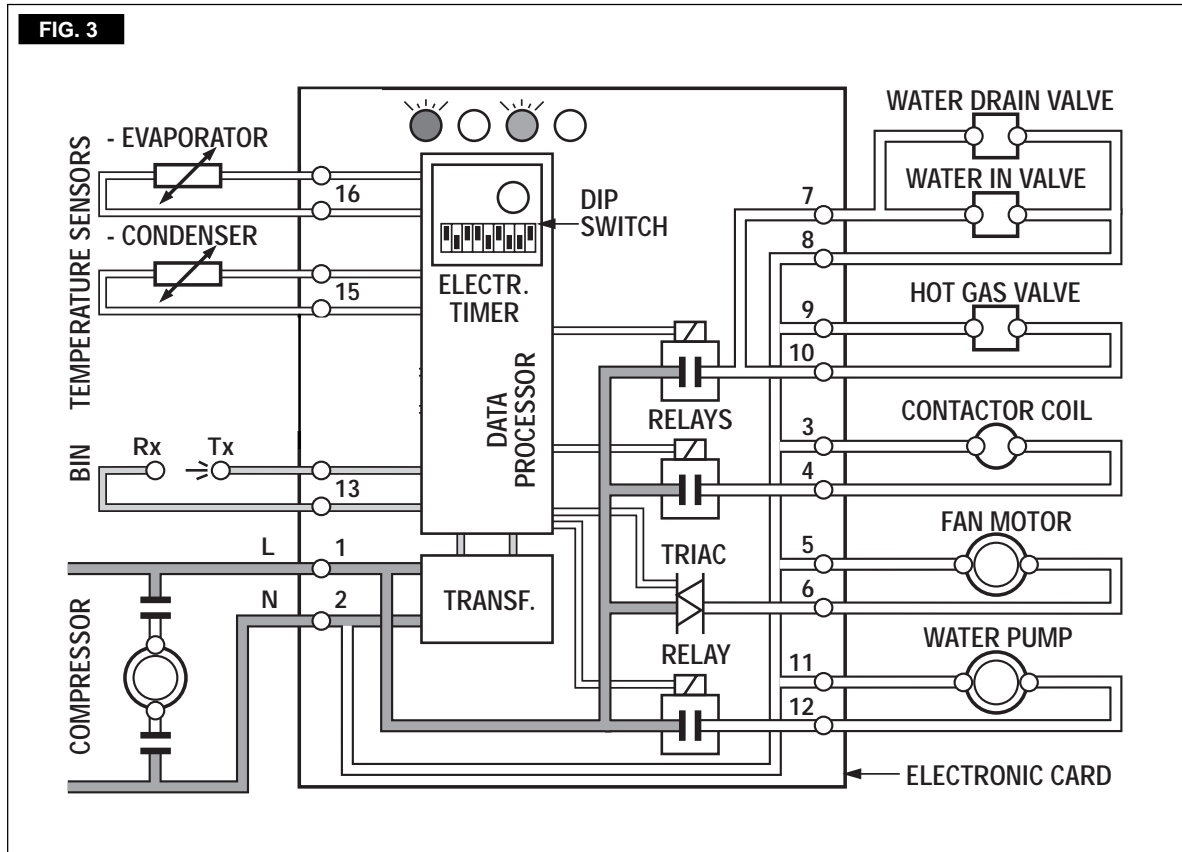

E. Check to see through the ice discharge opening that the spray system is correctly seated and that the water jets uniformly reach the

interior of the inverted mold cups; also make sure that the plastic curtain is hanging freely and there is not excessive water spilling through it.

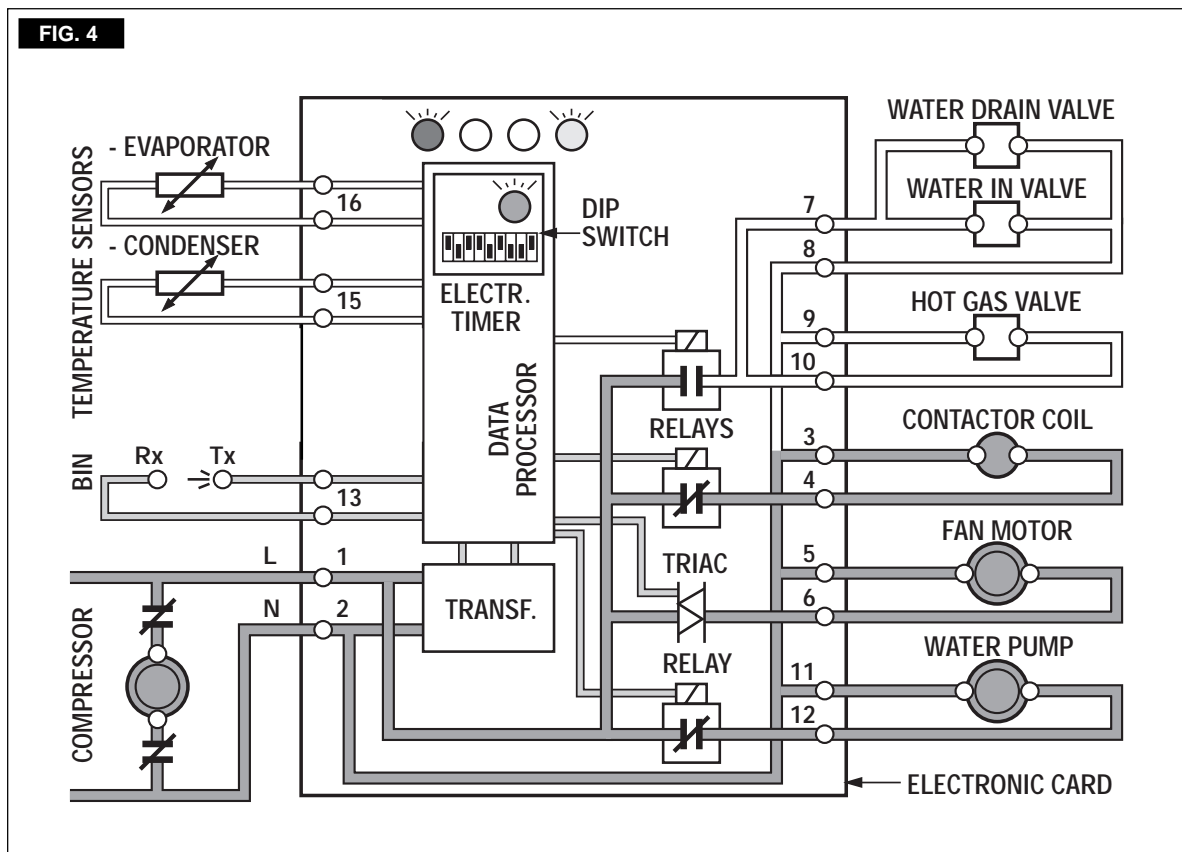

F. The ice making process takes place thereby, with the water sprayed into the molds that gets gradually refrigerated by the heat exchange with the refrigerant flowing into the evaporator serpentine. During the freezing process, when the evaporator temperature falls below an established value, the evaporator temperature sensor supplies a low voltage power signal to the electronic control device (P.C.BOARD) in order to activate an electronic timer. This one takes over the control of the freezing cycle up to the complete formation of the ice cubes (Fig.4).

NOTE. The length of the entire freezing cycle is governed by the evaporator temperature sensor which has its probe placed in contact with the evaporator serpentine (Non adjustable) in combination with the electronic timer (Adjustable) incorporated in the P.C.BOARD. The timer adjustment is factory set in consideration of the ice maker type, cooling version and ice cube size (Small, Medium, Large). It is possible, however, to modify the timed length of the freezing cycle, by changing the **DIP SWITCH** keys setting. In Table B of PRINCIPLE OF OPERATION are shown the various time extensions of the freezing cycle second phase, in relation with the different DIP SWITCH keys setting.

G. After about 17÷20 minutes from the beginning of the freezing cycle, in an hypothetic ambient temperature of 21°C, the defrost cycle takes place with the hot gas, the water inlet and the water drain valves simultaneously activated (Fig. 5).

The electrical components in operation on models are:

- COMPRESSOR**
- CONTACTOR COIL (EC 126-176 only)**
- WATER INLET VALVE**
- HOT GAS VALVE**
- WATER DRAIN VALVE**

and the
WATER PUMP
on the first 15 seconds.

NOTE. The length of the defrost cycle is automatically determined by the micro-processor of the P.C. BOARD in relation of the time necessary for the unit to reduce the evaporator temperature from 0°C (32°F) small Red LED blinking to -15°C (5°F) small Red LED ON steady - TIME T2. It is possible to extend the length of the defrost cycle by changing the setting of DIP SWITCH 7 and 8 as shown on table at page 32.

H. Check, during the defrost cycle, that the incoming water flows correctly into the sump reservoir in order to refill it and that the surplus overflows through the overflow drain tube.

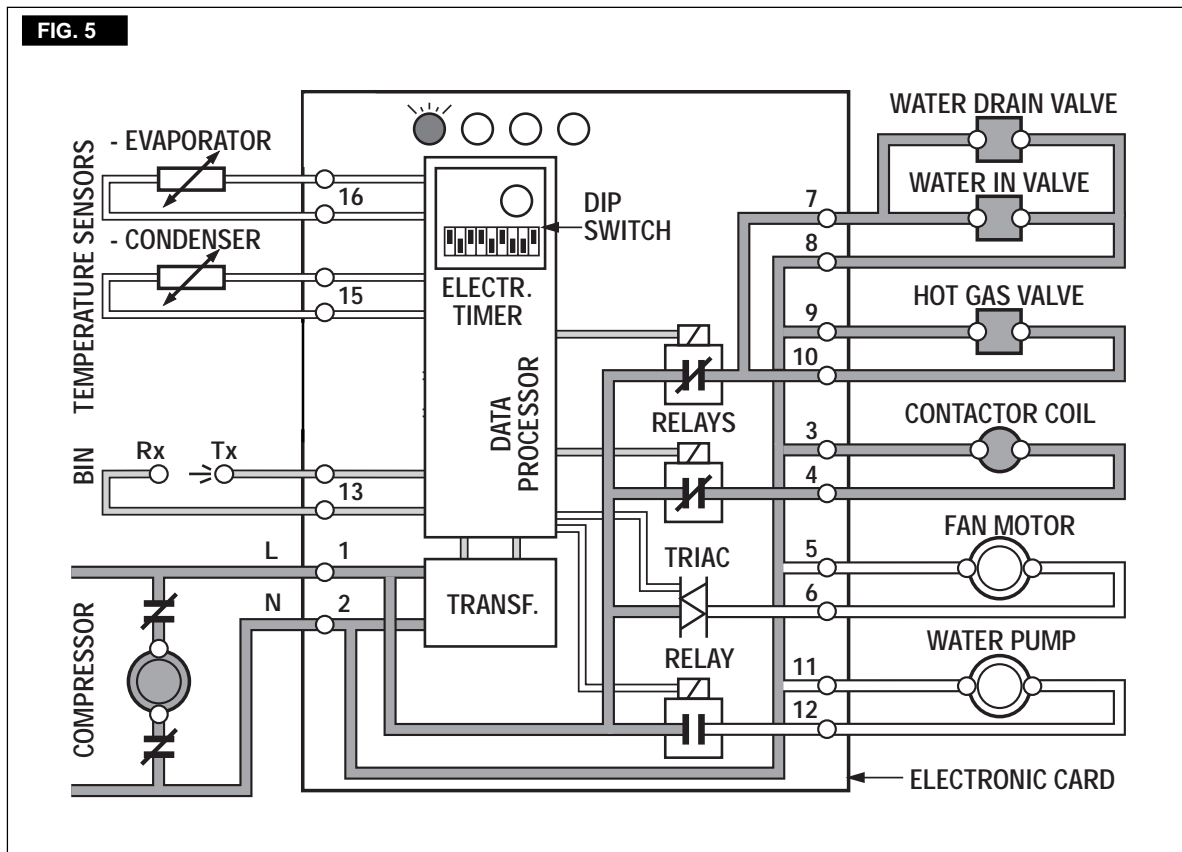

I. As soon as the water into the Sealed Water Reservoir reaches the maximum level, the two metal pins close the electrical contact through the water, transmitting a low voltage current to the Special Interface PC Board.

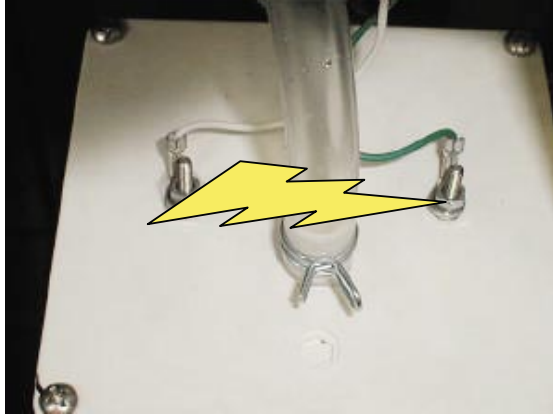

The Interface PC Board energises the Water Drain Pump for 8 seconds pumping out most of the water contained into the Sealed Water Reservoir.

J. Check the texture of ice cubes just released. They have to be in the right shape with a small depression of about 5-6 mm in their crown.

If not, wait for the completion of the second cycle before performing any adjustment.

If the ice cubes are shallow and cloudy, it is possible that the ice maker runs short of water during the freezing cycle second phase or, the quality of the supplied water requires the use of an appropriate water filter or conditioner.

K. To be sure of the correct operation of ice level control device, place one hand between its sensing "eyes" to interrupt the light beam.

The Bin Full **YELLOW LED** starts to blink, and after 60 seconds, the unit stops with the simultaneous glowing of the **same LED** to monitor the **BIN FULL** situation (Fig.6).



Take the hand out from the ice level control sensors to allow the resumption of the light beam. After approximately 10 seconds with the **YELLOW LED** blinking fast the ice maker resume its operation with the immediate glowing of the **FIRST YELLOW LED** indicating **UNIT IN OPERATION** and the extinguishing of the **"BIN FULL" YELLOW LED**.

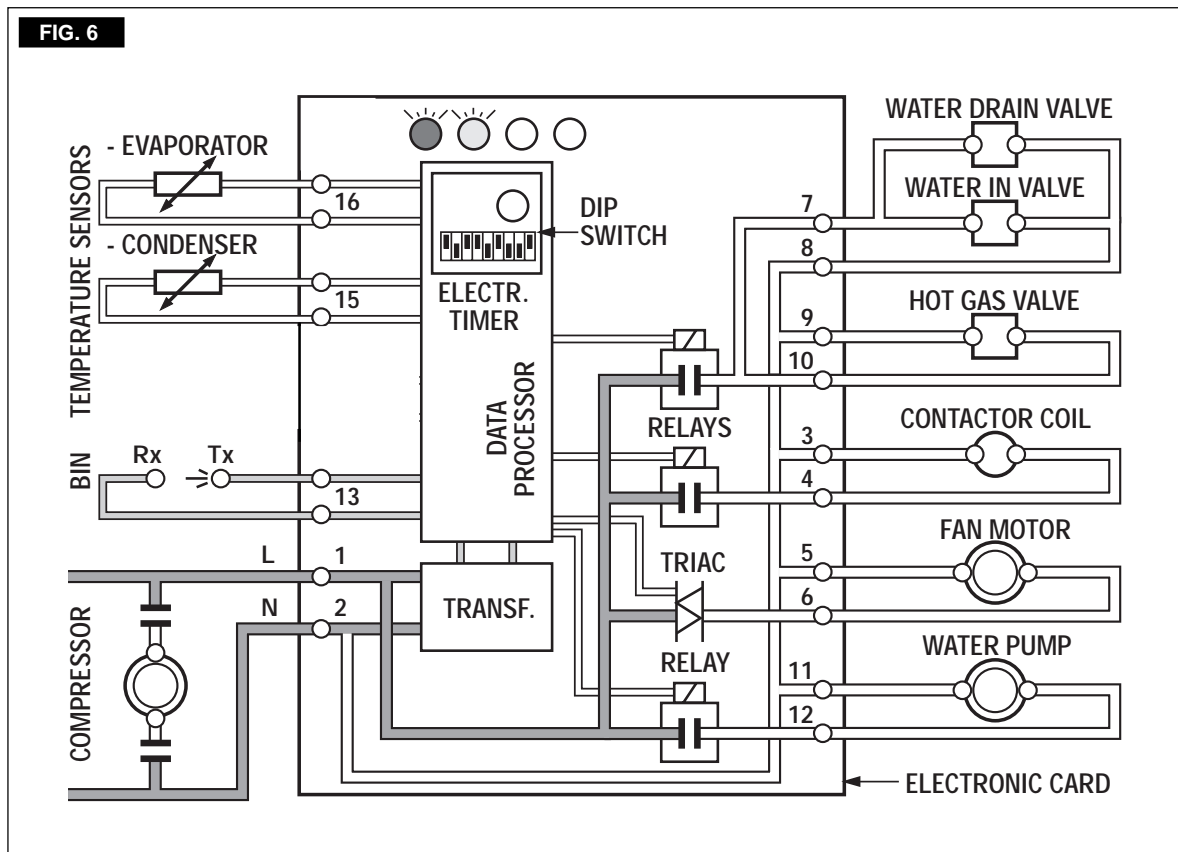

NOTE. The **ICE LEVEL CONTROL (INFRARED SYSTEM)** is independent of the temperature however, the reliability of its detection can be affected by external light radiations or by any sort of dirt and scale sediment which may deposit directly on the light source and on the receiver. To prevent any possible ice maker malfunction, due to negative affection of the light detector, it is advisable to locate the unit where it is **not reached by any direct light beam** or light radiation, also it is recommended to keep the bin door constantly closed and to follow the instructions for the **periodical cleaning of the light sensor elements** as detailed in the **MAINTENANCE AND CLEANING PROCEDURES**.
Its sensivity can be adjusted by turning the IR trimmer.

L. Remove, if fitted, the refrigerant service gauges and re-fit the unit service panels previously removed.

M. Instruct the owner/user on the general operation of the ice machine and about the cleaning and care it requires.

PRINCIPLE OF OPERATION

How it works

In the **SCOTSMAN** cube ice makers the water used to make the ice is kept constantly in circulation by an electric water pump which primes it to the spray system nozzles from where it is diverted into the inverted mold cups of the evaporator. A small quantity of the sprayed water freezes into ice; the rest of it cascades by gravity into the sump assembly below for recirculation.

FREEZING CYCLE

The hot gas refrigerant discharged out from the compressor reaches the condenser where, being cooled down, condenses into liquid.

Flowing into the liquid line it passes through the drier filter, then it goes all the way through the capillary tube where, due to the heat exchanging action, it loses some of its heat content so that its pressure and temperature are lowered as well.

Next the refrigerant enters into the evaporator serpentine (which has a larger I.D. than the capillary) and starts to boil off; this reaction is emphasized by the heat transferred by the sprayed water.

The refrigerant then increases in volume and changes entirely into vapor.

The vapor refrigerant then passes through the suction accumulator (used to prevent that any small amount of liquid refrigerant may reach the compressor) and through the suction line. In both the accumulator and the suction line it exchanges heat with the refrigerant flowing into the capillary tube (warmer), before to be sucked in the compressor and to be recirculated as hot compressed refrigerant gas.

The freezing cycle is controlled by the evaporator temperature sensor (which has its probe in contact with the evaporator serpentine) that determines the length of its first portion of the cycle. When the temperature of the evaporator serpentine drops to a pre-set value (small Red LED ON steady) the evaporator sensor probe changes its electrical resistance allowing a low voltage current (15 volts) to flow to the P.C. BOARD which in turn activates an electronic timer.

The timer, which is built-in the P.C. BOARD, takes over from the evaporator temperature sensor, the control of the freezing cycle up to its completion.

NOTE. *The change of the electric potential of the evaporator sensor with the consequent activation of the timer (Time mode) is signalled by the glowing-up of the RED LED located in the front of the P.C. BOARD.*

ATTENTION. In case, after 15 minutes from the beginning of the freezing cycle, the temperature of the evaporator sensor probe is higher than 0° C (32°F) - small Red LED still OFF - (shortage of refrigerant, inoperative hot gas valve, etc.) the P.C. BOARD switch OFF immediately the unit with the simultaneous blinking of the WARNING RED LED.

The length of this timed portion of the freezing cycle is pre-fixed and related to the setting of the first four DIP SWITCH keys.

The DIP SWITCH keys setting is made in consideration of the type of condenser used and size of ice cubes.

TAB. A DIP SWITCH FACTORY SETTING COMBINATIONS (PER MODEL AND VERSION)										
DIP SWITCH	FREEZING CYCLE				DEFROST CYCLE		DEFROST CYCLE ADD. TIME		15/30"	AIR/WATER
	1	2	3	4	5	6	7	8	9	10
ECM 106 A	ON	ON	OFF	ON	ON	OFF	ON	ON	OFF	ON
ECM 106 W	ON	ON	OFF	ON	ON	OFF	ON	ON	OFF	OFF
ECL 106 A	OFF	OFF	OFF	ON	OFF	ON	ON	ON	OFF	ON
ECL 106 W	OFF	OFF	OFF	ON	OFF	ON	ON	ON	OFF	OFF
ECM 126 A	ON	ON	OFF	ON	ON	OFF	ON	ON	OFF	ON
ECM 126 W	ON	ON	OFF	ON	OFF	ON	ON	ON	OFF	OFF
ECL 126 A	ON	ON	ON	OFF	OFF	ON	OFF	ON	OFF	ON
ECL 126 W	ON	ON	ON	OFF	OFF	ON	OFF	ON	OFF	OFF
ECM 176 A	ON	ON	OFF	ON	OFF	ON	ON	ON	OFF	ON
ECM 176 W	ON	ON	OFF	ON	OFF	ON	ON	ON	OFF	OFF
ECL 176 A	OFF	OFF	OFF	ON	OFF	ON	ON	ON	OFF	ON
ECL 176 W	OFF	OFF	OFF	ON	OFF	ON	ON	ON	OFF	OFF

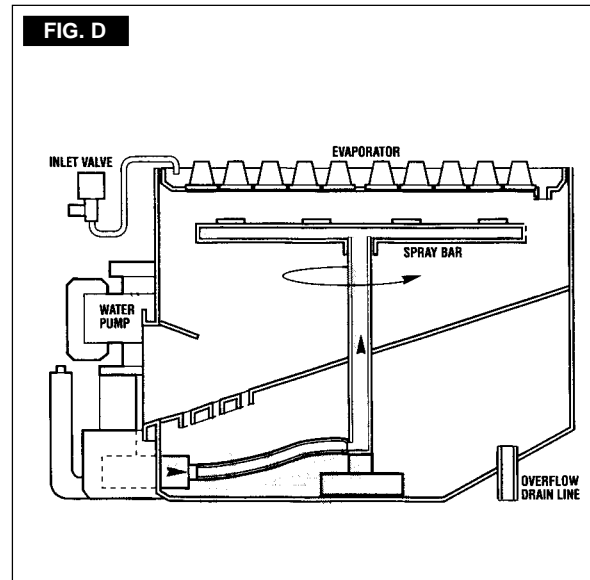
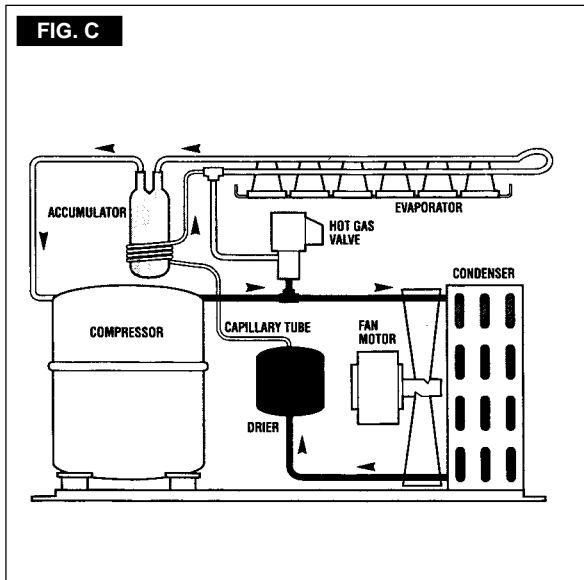
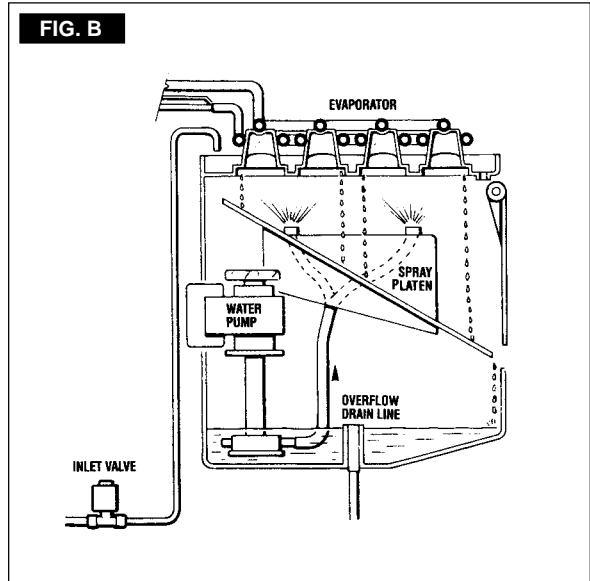
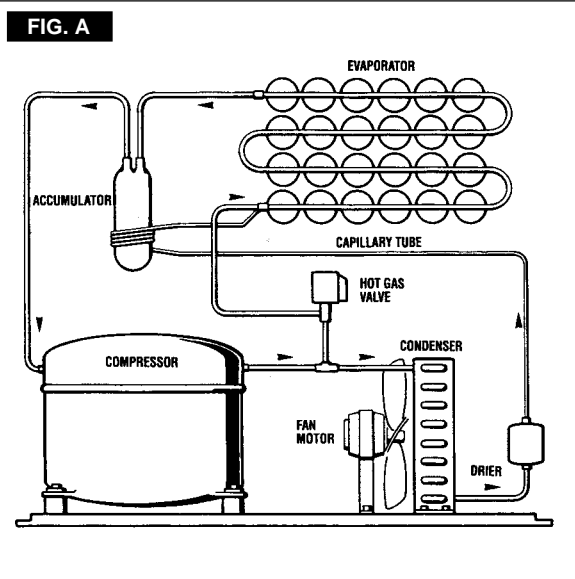

FIG. E

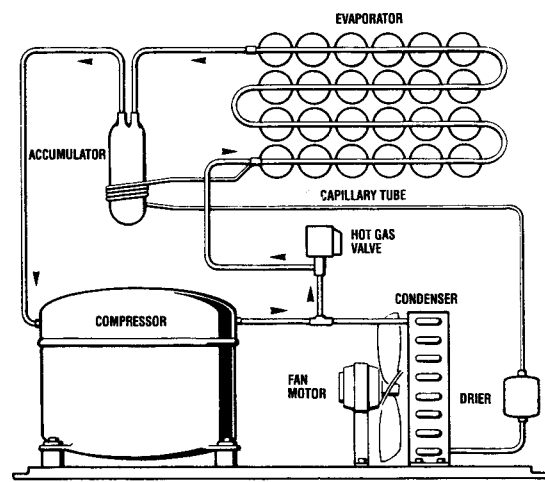

FIG. F

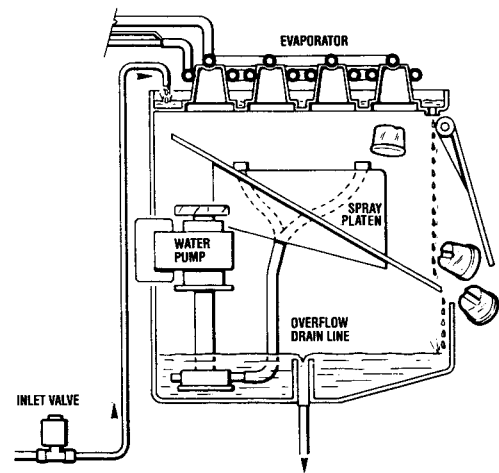

FIG. G

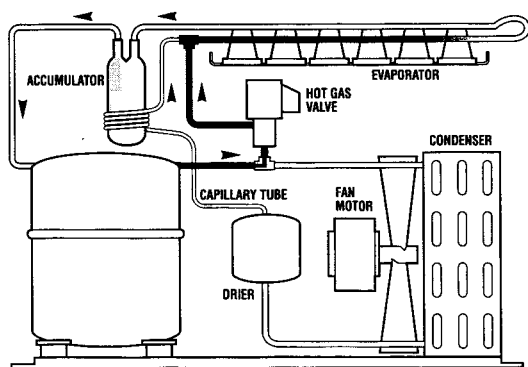
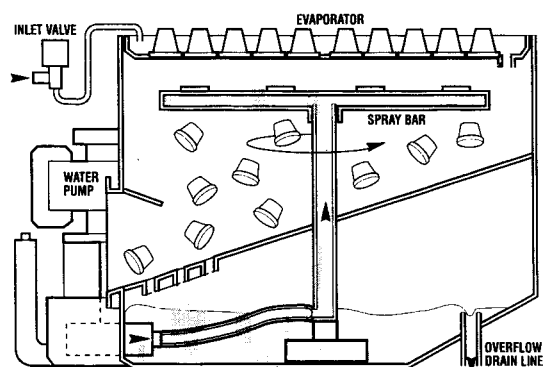

FIG. H



In Table B are indicated the various lengths of the timed portion of freezing cycle in relation to the different combinations of the DIP SWITCH KEYS. In Table A herebelow are illustrated the DIP SWITCH keys combinations for the different models and versions as they are set in the factory.

The electrical components in operation during the freezing cycle are:

COMPRESSOR

FAN MOTOR (in air cooled version)

WATER PUMP

CONTACTOR COIL (EC 126-176 only)

and during the second phase of freezing cycle (Time mode) they are joined by the

ELECTRONIC TIMER

The refrigerant head pressure, in the course of the freezing cycle, ranges between 8.5 and 9.5 bars (110÷130 psig) in the air cooled version, being controlled by the temperature sensor probe located within the condenser fins.

On the air cooled version, the condenser temperature sensor, when senses a rising of the condenser temperature beyond the pre-fixed limit, changes its electrical resistance and transmits a low voltage power flow to the Micro Processor of P.C. BOARD which in turn energizes, through a **TRIAC**, the **FAN MOTOR**. When the opposite situation occurs, i.e. the condenser temperature gets below the pre-fixed limit, the temperature sensor changes again its electrical resistance reducing therefore the current flow to the P.C. BOARD to cause the fan motor temporary cut-off.

NOTE. In case the condenser temperature probe senses that the condenser temperature has risen to 70°C (160°F) - on air cooled versions - or 60°C (140°F) - on water cooled versions - for one of the following reasons:

CLOGGED CONDENSER (Air cooled version)

INSUFFICIENT FLOW OF COOLING WATER (Water cooled version)

FAN MOTOR OUT OF OPERATION (Air cooled version)

AMBIENT TEMPERATURE HIGHER THEN 40°C (100°F)

it causes the total and immediate SHUT-OFF of the machine in order to prevent the unit from operating in abnormal and dangerous conditions.

When the ice maker stops on account of this protective device, there is a simultaneous glowing of the **RED LED** and **RED LIGHT (STEADY)**, warning the user of the **Hi Temperature** situation.

After having eliminated the source of the condenser hi-temperature, to restart the machine it is necessary to switch OFF (wait few seconds) and switch ON again the unit.

The ice machine resumes its normal operation by going through the 5 minutes water filling phase.

At the start of the freezing cycle the refrigerant suction or lo-pressure lowers rapidly to 1 bar -

14 psig - then it declines gradually - in relation with the growing of the ice thickness - to reach, at the end of the cycle, approx. 0÷0,1 bar -0÷0,3 psig - with the cubes fully formed in the cup molds. The total length of the freezing cycle ranges from 20 to 25 minutes.

DEFROST OR HARVEST CYCLE (Fig.E and G)

As the electronic timer has carried the system throughout the second phase of freezing cycle, the defrost cycle starts.

ATTENTION. In case the unit is able to reach 0°C (32°F) evaporating temperature within 15 minutes, but after 45 minutes from the beginning of the freezing cycle it has not yet reached the evaporator temperature of -15°C (5°F) the machine goes straight into the defrost cycle omitting the timed portion of the freezing cycle relied to the setting of the first four DIP SWITCHES.

NOTE. The length of the defrost cycle is related to the length of the second phase of freezing cycle T2. (Time to drop the evaporating temperature from 0°C (32°F) - small Red LED blinking - to -15°C (5°F) small Red LED ON steady. It is possible to extend the length of the defrost cycle by changing the setting of DIP SWITCH 7 and 8 as shown on table at page 32.

The electrical components in operation during this phase are:

COMPRESSOR

CONTACTOR COIL (EC 126-176 only)

WATER INLET VALVE

HOT GAS VALVE

WATER DRAIN VALVE

and the

WATER PUMP

on the first 15 seconds.

The incoming water, passing through the water inlet valve and the flow control, runs over the evaporator platen and then flows by gravity through the dribbler holes down into the sump/reservoir. (Fig. F and H)

The water filling the sump/reservoir forces part of the surplus water from the previous freezing cycle to go out to the waste through the overflow pipe. This overflow limits the level of the sump water which will be used to produce the next batch of ice cubes. Meanwhile, the refrigerant as hot gas, discharged from the compressor, flows through the hot gas valve directly into the evaporator serpentine by-passing the condenser. The hot gas circulating into the serpentine of the evaporator warms up the copper molds causing the defrost of the ice cubes. The ice cubes, released from the cups, drop by gravity onto a slanted cube chute, then through a curtained opening they fall into the storage bin.

At the end of the defrost cycle, the hot gas valve, the water inlet valve and the water drain valve close and the machine starts again a new freezing cycle.

PWD SYSTEM

COMPONENTS

The components of the Pump Out Water Drain System are

- Sealed water tank
- PC Board & Sensor
- Sealed Water Pump
- Check Valve

OPERATION

All water coming from the overflow, and from the melted ice is collected inside the Sealed Water Reservoir.

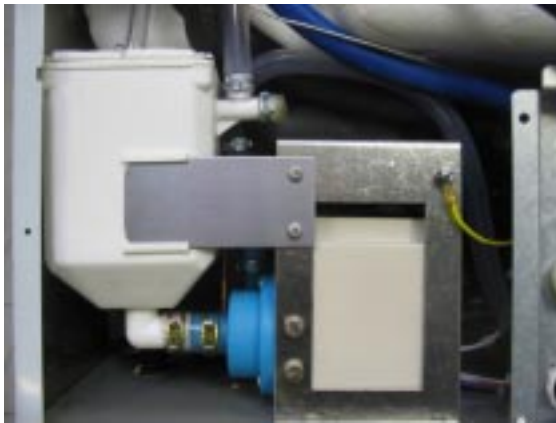

As soon as the water into the Sealed Water Reservoir reaches the maximum level, the two metal pins close the electrical contact through the water, transmitting a low voltage current to the PC Board.

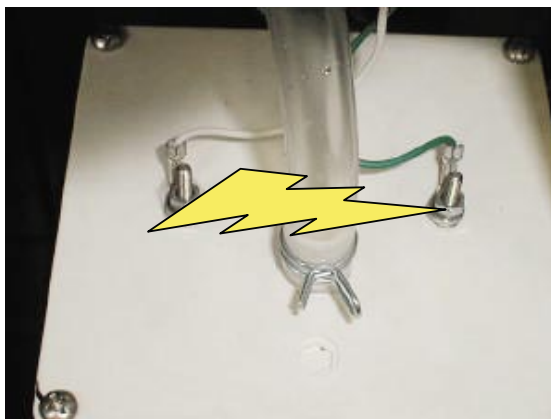

The PC Board activates the Water Drain Pump for 8 seconds pumping out most of

the water contained into the Sealed Water Reservoir.



The water can be pumped out up to 1.5 m rise or

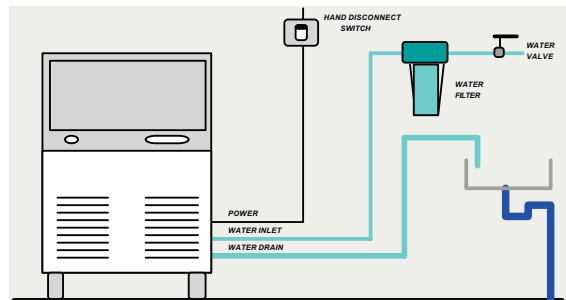

to 30 m on horizontal length.

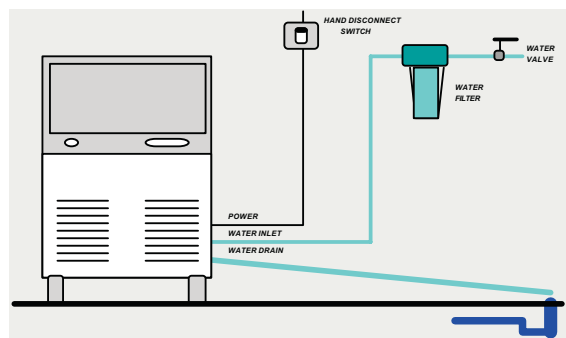

A Check Valve, located on the water drain hose, prevents the coming back of the discharged water.



SCHEMATIC SYSTEM

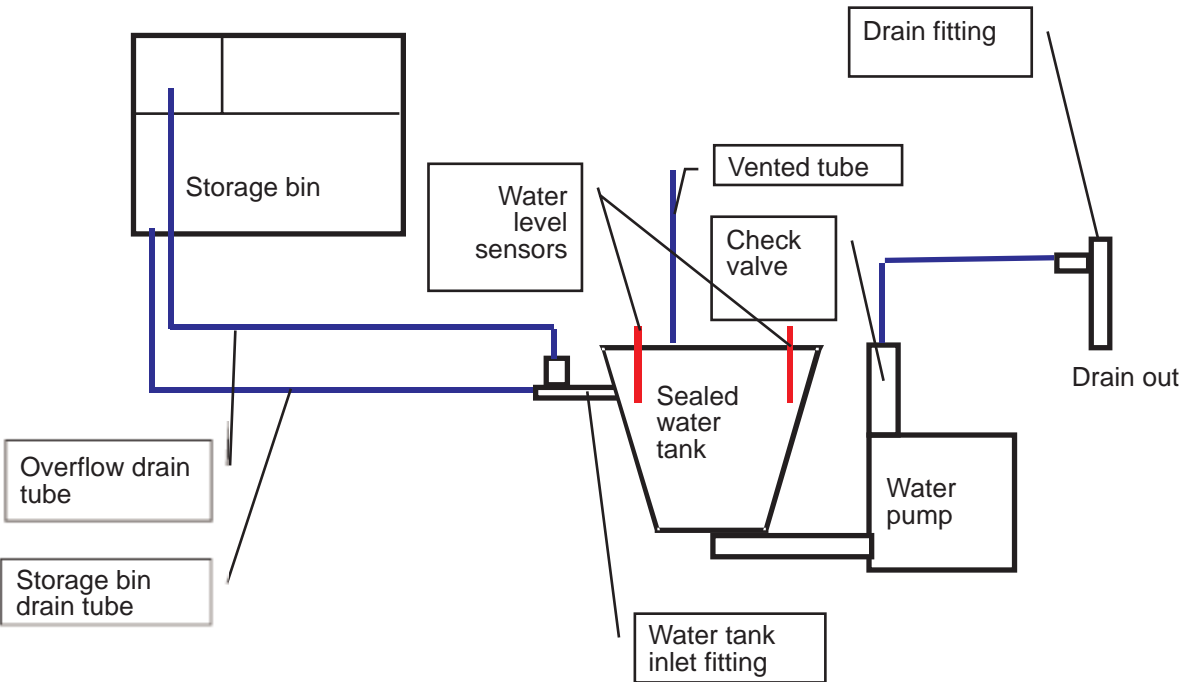

OPERATION - CONTROL SEQUENCE

At the start of freezing cycle the evaporator temperature sensor controls the length of the first part of the freezing cycle. As it reaches a predetermined temperature it supplies a low voltage current to the P.C. BOARD in order to activate the electronic timer which takes over the control of the freezing cycle for a pre-fixed time according to the DIP SWITCH keys setting (see Tab. B).

NOTE. The evaporator temperature sensor, factory pre-set, is the same for all the models and is not adjustable in the field.

Once completed the timed portion of the freezing cycle the system goes automatically into the defrost cycle which has also a pre-fixed length. At completion of the defrost cycle the P.C. BOARD command the unit to start again a new freezing cycle.

OPERATION - ELECTRICAL SEQUENCE

The following charts illustrate which switches and which components are ON or OFF during a particular phase of the icemaking cycle. Refer to the wiring diagram for a reference.

BEGINNING FREEZE

Electrical components (Loads)	ON	OFF
Compressor	●	
Fan Motor (Air cooled only) and TRIAC	●	
Hot Gas Valve		●
Water Inlet Valve		●
Water Drain Valve		●
P.C.Board Relay 1 Coil		●
P.C.Board Relay 2 & 3 Coil	●	
Water Pump	●	
Contacteur Coil (EC 126-176 only)	●	
P.C.B. Timer		●

Electronic Controls & Sensors	ON	OFF
Evaporator Sensor		●
Condenser Sensor	●	
Ice Level Control	●	

TIMED FREEZE

Electrical components (Loads)	ON	OFF
Compressor	●	
Fan Motor (Air cooled only) and TRIAC	●	●
Hot Gas Valve		●
Water Inlet Valve		●
Water Drain Valve		●
P.C.Board Relay 1 Coil		●
P.C.Board Relay 2 & 3 Coil	●	
Water Pump	●	
Contacteur Coil (EC 126-176 only)	●	
P.C.B. Timer	●	

Electronic Controls & Sensors	ON	OFF
Evaporator Sensor	●	
Condenser Sensor	●	●
Ice Level Control	●	

HARVEST (Drain portion - first 15/30 sec.)

Electrical components (Loads)	ON	OFF
Compressor	●	
Fan Motor (Air cooled only) and TRIAC		●
Hot Gas Valve	●	
Water Inlet Valve	●	
Water Drain valve	●	
P.C.Board Relay 1 & 2 Coil	●	
P.C.Board Relay 3 Coil	●	
Water Pump	●	
Contacteur Coil (EC 126-176 only)	●	
P.C.B. Timer	●	

Electronic Controls & Sensors	ON	OFF
Evaporator Sensor		●
Condenser Sensor		●
Ice Level Control	●	

HARVEST (Water filling portion)

Electrical components (Loads)	ON	OFF
Compressor	●	
Fan Motor (Air cooled only) and TRIAC		●
Hot Gas Valve	●	
Water Inlet Valve	●	
Water Drain valve	●	
P.C.Board Relay 1 & 2 Coil	●	
P.C.Board Relay 3 Coil		●
Water Pump		●
Contacteur Coil (EC 126-176 only)	●	
P.C. Board Timer	●	

Electronic Controls & Sensors	ON	OFF
Evaporator Sensor		●
Condenser Sensor		●
Ice Level Control	●	

OPERATING CHARACTERISTICS

EC 106-126-176

Freeze Cycle

Average Discharge
Pressure A/C: 9.5÷8.5 bar (130÷110 psig)

Average Discharge
Pressure W/C: 10.5÷9.5 bar (150÷135 psig)

Suction Pressure
End Freeze Cycle: 0 ÷ 0.1 bar (0 ÷ 1 psig)

REFRIGERANT METERING DEVICE:

capillary tube

REFRIGERANT CHARGE (R 134 A)

	Air cooled	Water cooled
EC 106	320 gr (11.0 oz.)	250 gr (9.0 oz.)
EC 126	450 gr (16.0 oz.)	300 gr (10.5 oz.)
EC 176	450 gr (16.0 oz.)	330 gr (12.0 oz.)

COMPONENTS DESCRIPTION

A. GREEN MASTER SWITCH PUSH BUTTON

Located in the front of the machine it's used to switch ON and OFF the unit by pushing its green push button. When ON, its green light is ON as well.

B. RED ALARM/RE-SET PUSH BUTTON

Located in the front of the machine (just beside the Master Switch) it works in conjunction with the Cleaning Remind Board and it's activated when:

- Condensing temperature is higher then 70°C (air cooled version) - **ON steady with machine in OFF mode**
- Condensing temperature is higher then 60°C (water cooled version) - **ON steady with machine in OFF mode**
- Condenser sensor out of order - **Blinking twice and repeat with machine in OFF mode**
- Condenser air filter need to be cleaned - **ON steady with machine in ON mode**
- Water system need to be cleaned - **Slow blinking with machine in ON mode.**

On the first two cases it's possible to Re-Set the operation of the machine pushing and hold the Red Alarm Re-Set Button by 5" till the Red Light is OFF.

On the third case, it's necessary first to replace the condenser sensor then, push and hold for 5" the Red Re-Set Button.

C. EVAPORATOR TEMPERATURE SENSOR

The evaporator temperature sensor probe, located in contact with the evaporator serpentine, detects the dropping of the evaporator temperature during the freezing cycle and signals it by supplying a current flow to the micro processor of P.C. BOARD.

According to the current received is energized the small Red LED of the PC Board (blink or steady). When steady, the micro processor supplies power to the electronic timer built into the P.C. BOARD so that it takes control of the last portion of freezing cycle.

The length of the timed phase is pre-fixed by the setting of the keys 1, 2, 3 and 4 of the DIP SWITCH.

NOTE. Whenever, after 15 minutes from the beginning of the freezing cycle, the evaporating temperature have not yet reached the value of 0°C (32°F) - small Red LED OFF - the P.C.Board switches OFF the machine with the **BLINKING** of **WARNING RED LED**.

D. CONDENSER TEMPERATURE SENSOR

The condenser temperature sensor probe, located within the condenser fins (air cooled version) or in contact with the tube coil (water cooled version) detects the condenser temperature variations and signals them by supplying current, at low voltage, to the P.C. BOARD.

In the air cooled versions, in relation to the different current received, the micro processor of the P.C. BOARD supplies, through a TRIAC, the power at high voltage to the fan motor so to cool the condenser and to reduce its temperature.

In case the condenser temperature rises and reaches **70°C (160°F)** - on air cooled models - or **60°C (140°F)** - on water cooled models - the current arriving to the micro processor is such to cause an immediate and total stop of the machine operation.

E. ICE BIN LEVEL LIGHT CONTROL

The electronic ice bin level control, located into the storage bin, has the function to stop the operation of the ice machine when the light beam between the light source and the sensor is interrupted by the ice cubes stored into the bin. When the light beam is interrupted the Bin Full YELLOW LED starts to blink; in case the light beam is constantly interrupted for more than 60 seconds, the ice machine stops with the glowing-up of the **Bin Full YELLOW LED** to monitor the situation of ice bin full.

The 60 seconds of delay prevent that an ice scoop movement or the ice dropping through the ice chute (interrupting for a while the light beam) can stop the operation of the unit.

Six seconds after the scoop out of the ice (with the resumption of the light beam between the two infrared sensor of ice level control) the ice machine restarts again with the extinguishing of the YELLOW LED.

printed circuits one at high and the other at low voltage integrated with two fuses one on power in (32mA) and one on power out (6.3 A), of four aligned **LEDS** monitoring the operation of the machine, of one extra monitoring **RED LED** (blink 0°C - steady - 15°C), of one **DIP SWITCH** with ten keys, of one push button, of input terminals for the leads of the sensor probes and input and output terminals for the leads of the ice maker electrical wires.

The P.C. BOARD is the brain of the system and it elaborates, through its micro processor, the signals received from the three sensors in order to control the operation of the different electrical components of the ice maker (compressor, water pump, solenoid valves, etc.).

F. P.C. BOARD (Data processor)

The **P.C. BOARD**, fitted in its plastic box located in the front of the unit, consists of two separated

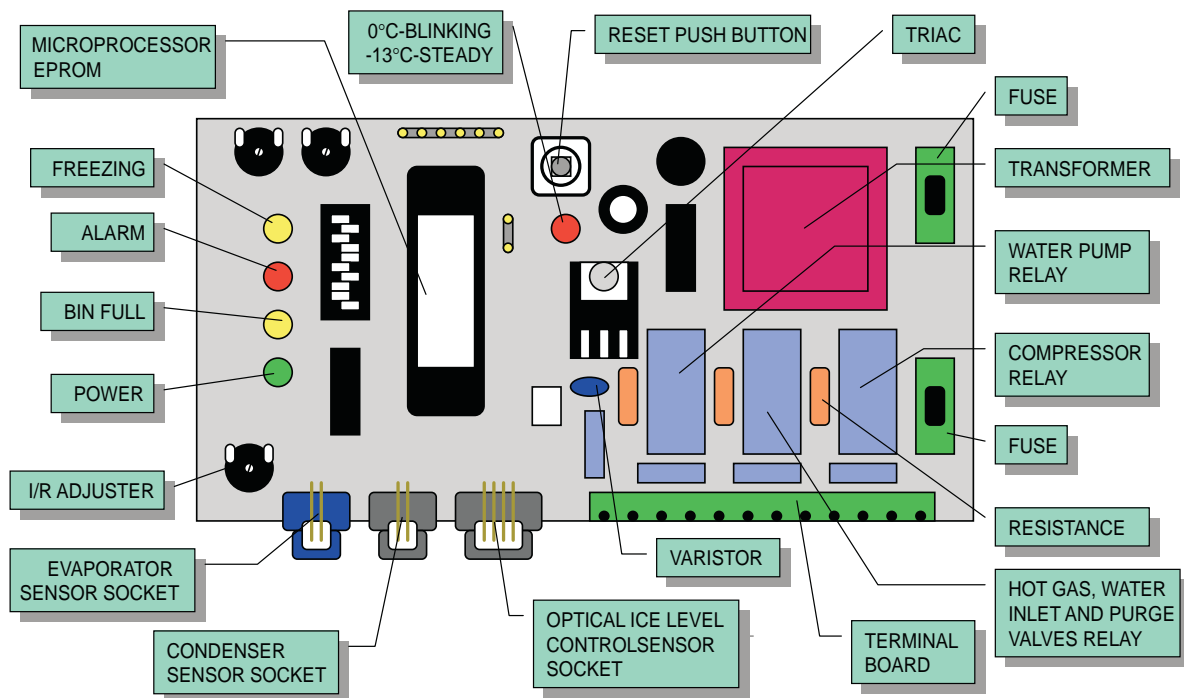

G. PUSH BUTTON OPERATION

DURING WATER FILLING PHASE

- Push for more then 2" but less then 5" the machine enters in Cleaning Mode
- Push for more then 5" the machine by-pass the Water Filling Phase

DURING FREEZING/HARVEST CYCLE

- Push for more then 5" during the Freezing cycle the machine goes immediately into Harvest
- Push for more then 5" during the Harvest cycle the machine enters immediately in the Freezing cycle

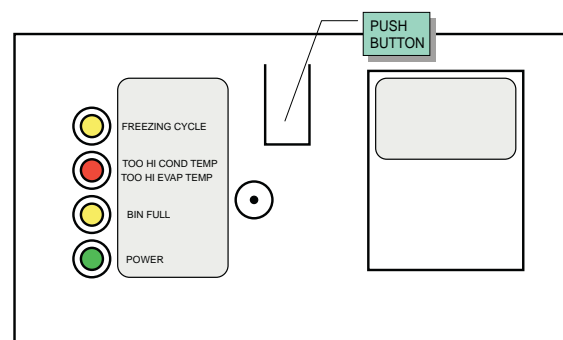

The length of Harvest is equal to:

- 35" if Push Button is activated before -15°C evaporating temperature LED activation
- As per Harvest cycle chart, if Push Button is activated after -15°C evaporating temperature LED activation (Red LED inside PC Board ON steady)

H. LED MEANING

GREEN LED ON
Unit under power

YELLOW BIN FULL LED ON

Unit shut-OFF at storage bin full

YELLOW BIN FULL LED BLINKING
Infrared beam break out

RED ALARM LED ON
Too hi condensing temperature
RED ALARM LED BLINKING
Too hi evaporating temperature

YELLOW FREEZING CYCLE ON
Unit in freezing cycle mode

YELLOW FREEZING LED AND RED ALARM LED ON
Condenser sensor out of order
YELLOW FREEZING LED AND RED ALARM LED BLINKING
Evaporator sensor out of order

The **DIP SWITCH N° 7 and 8** allow the extension of the length of the harvest/defrost cycle according to their combination as per following chart:

DIP SWITCH		ADDITIONAL DEFROST TIME
7	8	
ON	ON	0
OFF	ON	30"
ON	OFF	60"
OFF	OFF	90"

I. DIP SWITCH

The P.C.BOARD which controls the entire operation of the ice maker, has a **DIP SWITCH with ten switching keys** which allow to set up the micro processor program in order to extend or to shorten the length of freezing cycle in relation to the different model and versions of ice machines.

The **DIP SWITCH first four keys setting** determines the length of the 2nd phase of freezing cycle (controlled by the electronic timer) as detailed in the table B.

The **DIP SWITCH keys 5 & 6 setting** determines the length of the defrost cycle according to the size of the cubes (Large or Medium) as per the following setting:

- ON ON : PROGRAM A
- ON OFF : PROGRAM B
- OFF OFF : PROGRAM C
- OFF ON : PROGRAM D

LENGTH OF HARVEST CYCLE ACCORDING TO THE TIME TO DROP THE EVAP. TEMPERATURE FROM 0°C TO -15°C

LENGTH HARVEST CYCLE	PROGRAMS			
	A	B	C	D
180"	Up to 6'30"	***	Up to 9'30"	xxxx
165"	6'30"-7'	Up to 3'	9'30"-10'	xxxx
150"	7'-8'	3'-3'15'	10'-11'	xxxx
135"	8'-9'	3'15"-3'30"	11'-12'	xxxx
120"	9'-10'30"	3'30"-4'30"	12"-13'30"	< 3'
105"	10'30"-12'	4'30"-6'	13'30"-15'	3' - 4'
90"	>12'	>6'	>15'	> 4'

The **9th key** is used to supply power to the water pump for the first **15 seconds** of the defrost cycle - **position OFF** - or for the first **30 seconds** - **position ON**.

The **10th key** is used to modify the CUT-OUT condensing temperature **from 70°C (160°F)** for the air cooled versions - **ON position** - to **60°C (140°F)** - **OFF position** - for the water cooled versions.

L. CLEANING REMIND PC BOARD

Located on the front left side of the machine, it works in conjunction with the condenser sensor and the Red Alarm Re-Set Push Button.

It is used to energise the Water Drain Pump any time the level of the water into the Sealed water Reservoir reaches the upper metal pins (low power electrical circuit closed through the water). The water pump is kept energised by the PWD PC Board for 8 seconds.

It consists of a Printed Circuit Board with a step down transformer (230V - 12V), a relay, a Dip Switch with two keys, a Jumper for the set up of the Cut OFF/Alarm condensing temperature (70°C - jumper OUT - for air cooled version and 60°C - jumper IN - for water cooled version), a green four contacts connector for power IN and OUT, a Red socket for the Water Level Sensor

TAB. B LENGTH OF TIMED PORTION OF FREEZING CYCLE ACCORDING TO THE DIP SWITCH SETTING COMBINATIONS													
1 2 3 4					1 2 3 4								
1	ON OFF	■ ■ ■ ■	■ ■ ■ ■	■ ■ ■ ■	■ ■ ■ ■	25 min.	8	ON OFF	■ ■ ■ ■	■ ■ ■ ■	■ ■ ■ ■	■ ■ ■ ■	11 min.
2	ON OFF	■ ■ ■ ■	■ ■ ■ ■	■ ■ ■ ■	■ ■ ■ ■	23 min.	9	ON OFF	■ ■ ■ ■	■ ■ ■ ■	■ ■ ■ ■	■ ■ ■ ■	9 min.
3	ON OFF	■ ■ ■ ■	■ ■ ■ ■	■ ■ ■ ■	■ ■ ■ ■	21 min.	10	ON OFF	■ ■ ■ ■	■ ■ ■ ■	■ ■ ■ ■	■ ■ ■ ■	7 min.
4	ON OFF	■ ■ ■ ■	■ ■ ■ ■	■ ■ ■ ■	■ ■ ■ ■	19 min.	11	ON OFF	■ ■ ■ ■	■ ■ ■ ■	■ ■ ■ ■	■ ■ ■ ■	5 min.
5	ON OFF	■ ■ ■ ■	■ ■ ■ ■	■ ■ ■ ■	■ ■ ■ ■	17 min.	12	ON OFF	■ ■ ■ ■	■ ■ ■ ■	■ ■ ■ ■	■ ■ ■ ■	3 min.
6	ON OFF	■ ■ ■ ■	■ ■ ■ ■	■ ■ ■ ■	■ ■ ■ ■	15 min.	13	ON OFF	■ ■ ■ ■	■ ■ ■ ■	■ ■ ■ ■	■ ■ ■ ■	1 min.
7	ON OFF	■ ■ ■ ■	■ ■ ■ ■	■ ■ ■ ■	■ ■ ■ ■	13 min.							

Black socket for the Condenser Sensor and a White socket for the Red Alarm Re-Set Push Button.

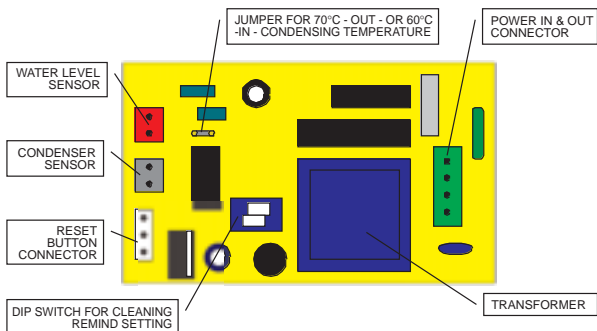

The main function of this PC Board is to switch OFF the machine when the condensing temperature is higher of its setting value or signal out the need for the cleaning of the condenser air filter (air cooled only) or of the water system. The time between the signal out for the cleaning of the water system can be modified according to the setting of the two Dip Switches as below:

TIME	1	2
1 MONTH	ON	ON
3 MONTHS	OFF	ON
6 MONTHS	ON	OFF
1 YEAR	OFF	OFF

Once cleaned the water system, it's necessary to cancel the time stored into the PC Board by pushing and hold for more then 20" the Red Alarm Re-Set Button till it starts to blink.

M. CONDENSER AIR FILTER (Air cooled version)

Located in front of the air cooled condenser can be removed by withdrawing it through the opening of the front panel for cleaning or replacing. A lower plastic guide, installed inside the unit, is used for the correct sliding and location of the air filter.

N. WATER SPRAY SYSTEM

Through its nozzles, the water pumped, is sprayed in each individual cup to be frozen into ice. It consists of one spray tube where are located several spray nozzles.

O. WATER PUMP

The water pump operates continually throughout the freezing cycle and on the first 15 or 30 seconds of the defrost cycle so to such the remaining water from the sump tank (reach in mineral salts) and drain it out. During the freezing

cycle the pump primes the water from the sump to the spray system and through the spray nozzles sprays it into the inverted cup molds to be frozen into crystal clear ice cubes. It is recommended that the pump motor bearings be checked at least every six months.

P. WATER INLET SOLENOID VALVE - 3/4 MALE FITTING (EC 106 water cooled version only)

A special water inlet solenoid valve with one inlet and two outlets (one for condenser and the second for the production of ice) is used on water cooled version. An automatic hi pressure control activates the second coil of the water inlet solenoid valve so to supply a metered amount of water to the condenser and drop down its temperature and pressure.

Q. HOT GAS SOLENOID VALVE

The hot gas solenoid valve consists basically in two parts: the valve body and the valve coil. Located on the hot gas line, this valve is energized through the micro processor of P.C. BOARD during the defrost cycle as well as during the water filling phase. During the defrost cycle the hot gas valve coil is activated so to attract the hot gas valve piston in order to give way to the hot gas discharged from compressor to flow directly into the evaporator serpentine to defrost the formed ice cubes.

R. FAN MOTOR (Air cooled version)

The fan motor is controlled through the P.C. BOARD and the TRIAC by the condenser temperature sensor. Normally it operates only during the freezing cycle to draw cooling air through the condenser fins. In the second part of the freezing cycle, the fan motor can run at intermittance as the condenser pressure must be kept between two corresponding head pressure values.

S. COMPRESSOR

The hermetic compressor is the heart of the refrigerant system and it is used to circulate and retrieve the refrigerant throughout the entire system. It compresses the low pressure refrigerant vapor causing its temperature to rise and become high pressure hot vapor which is then released through the discharge valve.

T. HI PRESSURE CONTROL (EC 106 water cooled version only)

Used only on the water cooled versions it operates to keep between 9.5 and 10.5 bars (135 ÷ 150 psig) the hi-side or discharge pressure of the refrigerant system by energizing the coil of the water inlet solenoid valve that control the cooling water flow to the condenser.

**U. WATER REGULATING VALVE - EC 126-176
(Water cooled version)**

This valve controls the head pressure in the refrigerant system by regulating the flow of water going to the condenser.

As pressure increases, the water regulating valve opens to increase the flow of cooling water.

V. CONTACTOR - EC 126-176

Placed outside of the control box it is controlled by the P.C. BOARD in order to close or open the electrical circuit to the compressor.

**Z. WATER DRAIN SOLENOID VALVE -
EC 126-176**

The water drain solenoid valve, electrically connected in parallel to the water inlet and to the hot gas solenoid valves, is energized for all the length of the defrost cycle.

By means of the water pump, that remains energized for 15 seconds at the beginning of the defrost cycle, it allows the drain out of all remaining water (rich of minerals deposited during the previous freezing cycle) from the sump tank.

By doing so it allows to the ice maker to make every new freezing cycle with new fresh water, avoiding thereby the accumulation of sediments and scales, which soon or later will cause the partial or total clogging of the water system on the unit.

ADJUSTMENT PROCEDURES

A. ADJUSTMENT OF THE CUBE SIZE

CAUTION. Before performing actual adjustment of the cube size, check other possible causes for cube size problems, refer to the Service Diagnosis Section for problem review and analysis. Do not perform any adjustment till the icemaking system has progressed through several complete freezing and harvest cycle, to observe size and quality of ice cubes and whether or not the cube size problem exists.

I. If the cubes are shallow size (Indentation is too deep) probably the length of the second phase of the freezing cycle is too short so, to extend such length you have to:

1. Locate the DIP SWITCH on the front of the P.C.Board.
2. Take note of the combination of the first four DIP SWITCH KEYS and check the corresponding length of freezing cycle 2nd phase on Table B.
3. Set the same DIP SWITCH KEYS to correspond to the prior combination shown on Table B which allow an extension of two more minutes of the length of the freezing cycle.
4. Observe the ice cubes in the next two harvests and eventually repeat steps 2 and 3 above until proper ice cubes size is achieved. See figure.

II. If the cubes are oversize size (Indentation is too full) probably the length of the second phase of the freezing cycle is too long. To shorten such length you have to:

1. Locate the DIP SWITCH on the front of the P.C.Board.
2. Take note of the combination of the first four DIP SWITCH KEYS and check the corresponding length of freezing cycle 2nd phase on Table B.
3. Set the same DIP SWITCH KEYS to correspond to the next combination shown on Table B which allow a reduction of two minutes of the length of the freezing cycle.
4. Observe the ice cubes in the next two harvests and eventually repeat steps 2 and 3 above until proper ice cubes size is achieved. See figure.

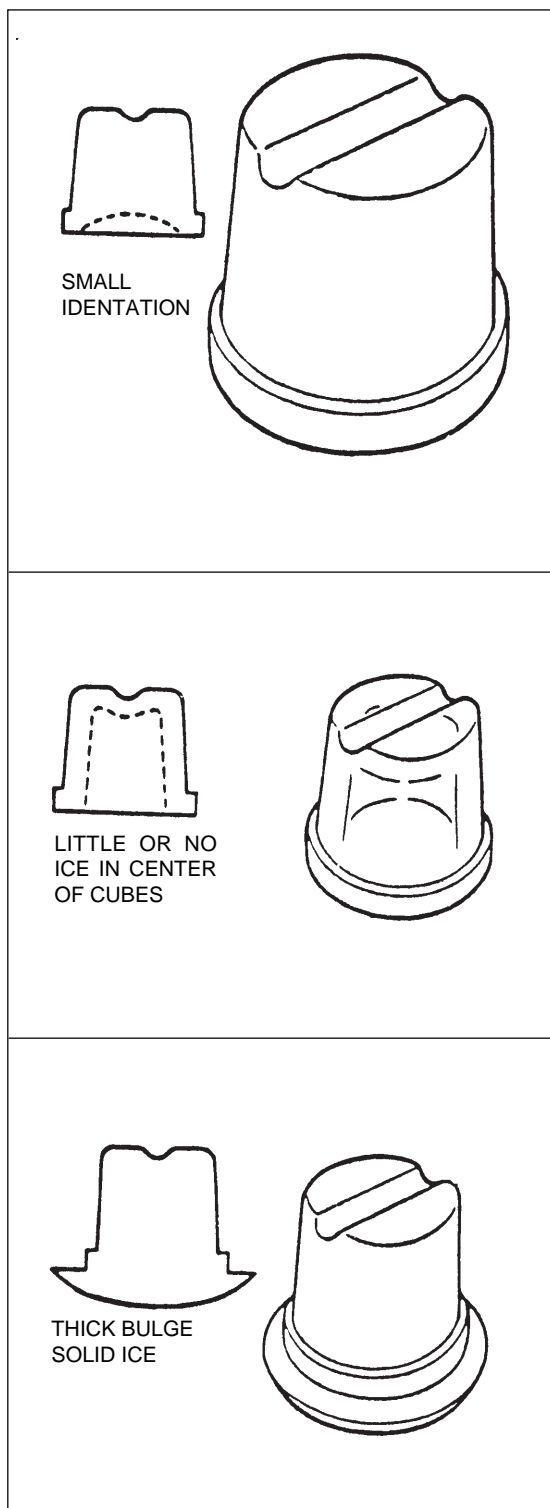

WIRING DIAGRAM

EC 106 AIR AND WATER COOLED 230/50-60/1

The unit is shown on freezing cycle

- BN BROWN
- BU BLUE
- GY GREY
- GNYE GREEN-YELLOW
- GN GREEN
- RD RED
- YE YELLOW
- WH WHITE
- OG ORANGE
- PK PINK
- BK BLACK

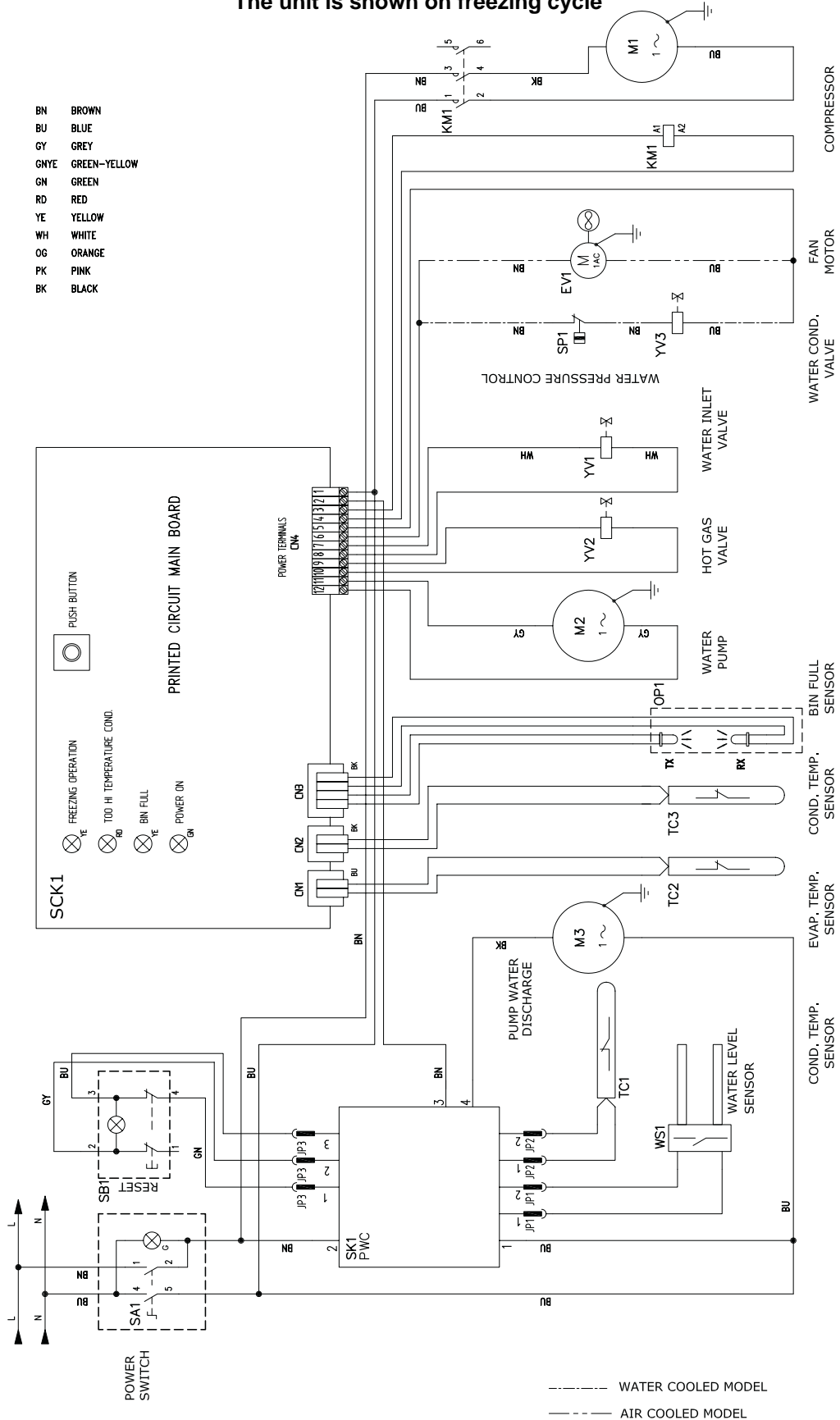

SERVICE DIAGNOSIS

SYMPTOM	POSSIBLE CAUSE	SUGGESTED CORRECTION
<p>Unit will not run (No warning LEDS glows)</p> <p>(Green LED-Power ON glows)</p> <p>(Bin full LED glows)</p> <p>(Red-alarm LED-LIGHT glows)</p> <p>(Red-alarm LED blinks)</p> <p>(Freezing LED + Red-alarm LED glows) and Red-alarm Light blinks twice and repeat</p> <p>(Freezing LED + Red-alarm LED blinks)</p>	<p>Blown power in fuse in P.C.Board</p> <p>Main switch in OFF position</p> <p>Inoperative P.C.Board</p> <p>Loose electrical connections</p> <p>Blown power out fuse in P.C. Board</p> <p>Inoperative ice level control</p> <p>Inoperative P.C.Board</p> <p>High head pressure</p> <p>High evaporating temperature after 15 mins. beginning freeze</p> <p>Condenser sensor out of order</p> <p>Evaporator sensor out of order</p>	<p>Replace fuse & check for cause of blown fuse</p> <p>Turn switch to ON position</p> <p>Replace P.C.Board</p> <p>Check wiring</p> <p>Replace fuse & check for cause of blown fuse</p> <p>Clean or replace ice level control</p> <p>Replace P.C.Board</p> <p>Inoperative fan motor. Replace Shortage of water (WC)</p> <p>Hot gas valve leak - Replace it. Water inlet valve leak - Replace it. Short of refrigerant. Compressor cycles intermittently</p> <p>Replace it</p> <p>Replace it</p>
<p>Compressor cycles intermittently</p>	<p>Low voltage</p> <p>Contactors with burnt contacts EC 126-176 only</p> <p>Non-condensable gas in system</p> <p>Compressor starting device with loose wires</p> <p>Mechanical problem</p>	<p>Check circuit for overloading Check voltage at the supply to the building. If low, contact the power company</p> <p>Replace it</p> <p>Purge the system</p> <p>Check for loose wires in starting device</p> <p>Replace compressor</p>
<p>Cubes too small</p>	<p>Freezing cycle too short</p> <p>Capillary tube partially restricted</p> <p>Moisture in the system</p> <p>Shortage of refrigerant</p>	<p>Review setting of DIP SWITCH keys</p> <p>Blow charge, add new gas & drier, after evacuating system with vacuum pump</p> <p>Same as above</p> <p>Check for leaks & recharge</p>
<p>Cloudy cubes</p>	<p>Shortage of water</p> <p>Dirty water supply</p> <p>Accumulated impurities</p>	<p>See remedies for shortage of water</p> <p>Use water softener or water filter</p> <p>Use SCOTSMAN Ice Machine cleaner</p>

SERVICE DIAGNOSIS

SYMPTON	POSSIBLE CAUSE	SUGGESTED CORRECTION
Shortage of water	Water spilling out through curtain Water solenoid valve not opening Water leak in sump area Water flow control plugged Leak of water drain valve	Check or replace curtain Replace valve Locate and repair Replace water inlet valve Replace valve
Irregular cubes size & some cloudy	Some jets plugged Shortage of water Unit not level	Remove jet cover and clean See shortage of water Level as required
Cubes too large	Freezing cycle too long	Review setting of DIP SWITCH keys
Decreased ice capacity	Inefficient compressor Leaky water valve Non-condensable gas in system Poor air circulation or excessive hot location (Red-alarm LED glows) Overcharge of refrigerant Capillary tube partially restricted Hot gas solenoid valve leaking Short of refrigerant Discharge head pressure too high	Replace Repair or replace Purge the system Relocate the unit or provide for more ventilation Correct the charge. Purge off slowly Blow charge, add new gas & drier, after evacuating system with vacuum pump Replace valve Charge to data plate indication See incorrect discharge pressure
Poor harvest	Restriction in incoming water line Water inlet valve not opening Hot gas valve orifice restricted Clogged air vented holes in mold cups Discharge head pressure too low	Check water valve strainer and flow control. If necessary enlarge the flow control orifice Valve coil with open winding Replace valve Replace hot gas valve assy Clean out holes plugged See incorrect discharge pressure

SERVICE DIAGNOSIS

SYMPTON	POSSIBLE CAUSE	SUGGESTED CORRECTION
Unit won't harvest	Inoperative P.C.Board Hot gas valve not opening Water solenoid valve not opening	Replace P.C.Board Valve coil with open winding Replace valve Valve coil with open winding Replace valve
Incorrect discharge pressure	Inoperative condenser sensor Inoperative P.C.Board Water regulating valve misadjusted (EC 126-176 only)	Replace sensor Replace P.C.Board Adjust its setting stem
Excessive water in unit base	Water tubing leaking	Check. Tighten or replace

MAINTENANCE AND CLEANING INSTRUCTIONS

A. GENERAL

The periods and the procedures for maintenance and cleaning are given as guides and are not to be construed as absolute or invariable.

Cleaning, especially, will vary depending upon local water and ambient conditions and the ice volume produced; and, each icemaker must be maintained individually, in accordance with its particular location requirements.

B. ICEMAKER

The following maintenance should be scheduled at least two times per year on these icemakers.

1. Check and clean the water line strainer.
2. Check that the icemaker is levelled in side to side and in front to rear directions.
3. Check for water leaks and tighten drain line connections. Pour water down bin drain line to be sure that drain line is open and clear.
4. Check size, condition and texture of ice cubes. Perform adjustment of cube size control as required.
5. Check the ice level control sensor to test shut-off. Put your hand between the light source and the receiver so to cut off the light beam for at least one minutes. This should cause the ice maker to shut off and the light up of the 2nd LED (yellow light).

NOTE. Within few seconds after the removal of the hand from the Infrared sensing light the icemaker restarts in freezing cycle. The ice level control uses devices that sense light, therefore they must be kept clean enough so they can "see". Every month clean/wipe the sensing "eyes" with a clean soft cloth.

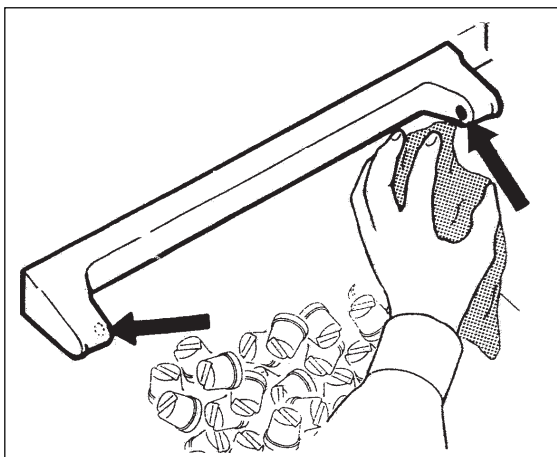

6. Check for refrigerant leaks.

C. CLEAN - REPLACE OF AIR CONDENSER FILTER

NOTE. The new AC series, in the air cooled version, are standard equipped with an air condenser filter as well as a Cleaning Reminder Board to remind to the end user the need for the cleaning of the air filter or of the water system (Red Alarm Light ON Steady or Blinking respectively with machine in operation).

1. Withdraw the air filter from the front through the opening of the front panel.



2. Blow pressurised air on the opposite direction of the condenser air flow so to remove the dust accumulated.
3. If pressurised air is not available, use tap water always in the counter flow air direction. Once cleaned shake it so to remove most of the accumulated water, then dry it using an hair dryer.

NOTE. In case the air filter strainer is damaged replace it with a new one.

4. Install it again by pushing it through the front panel opening.

D. CLEANING/SANITISING INSTRUCTIONS OF WATER SYSTEM

Clean-sanitise the water system, evaporator, bin and spray jets using a solution of SCOTSMAN Ice Machine Cleaner/Sanitizer.

NOTE. Cleaning requirements vary according to the local water conditions and individual user operation. Continuous check of the clarity of ice cubes and visual inspection of the water spraying parts before and after cleaning will indicate frequency and procedure to be followed in local areas.

1. Remove the front and top panels to gain access either to the control box and to the evaporator.
2. Make sure that all ice cubes have been released from their cups, then switch OFF the machine at front master button switch.
3. Scoop out all the ice cubes stored into the bin in order to prevent them from being contaminated with the cleaning solution.
4. Remove the plastic cup located on the bottom of sump/freezing chamber to drain out all water and scale deposits.



5. Lift up and remove the curtain.

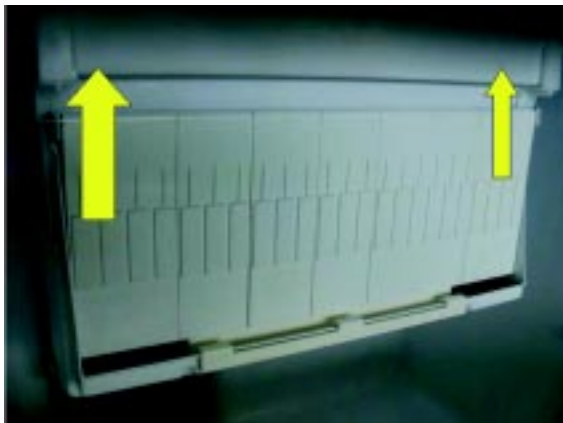

6. Lift up the entire spray platen from its bottom seat and take it out to clean it separately.

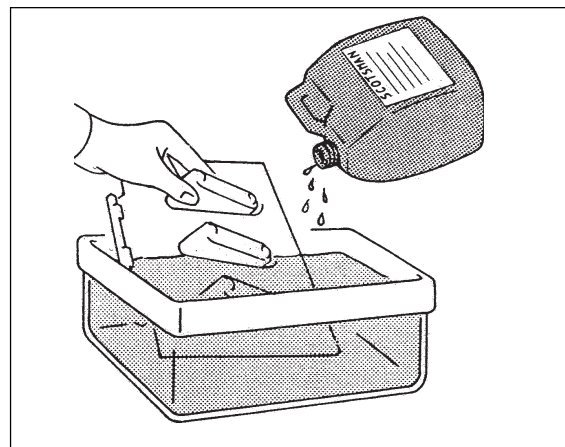

7. Using a bottle, pour fresh water into the bottom of the sump/freezing chamber to clean out most of scale deposit.
8. Install again the spray platen, the curtain as well as the bottom plastic cup.

Cleaning

9. Prepare the cleaning solution by diluting in a plastic container two liters of warm water (45°-50°C) with 0,2 liters of Ice Machine Cleaner.

WARNING. The SCOTSMAN Ice Machine Cleaner contains Phosphoric and Hydroxyacetic acids.

These compounds are corrosive and may cause burns if swallowed, DO NOT induce vomiting. Give large amounts of water or milk. Call Physician immediately. In case of external contact flush with water. KEEP OUT OF THE REACH OF CHILDREN.

10. Remove the evaporator cover then slowly pour onto the evaporator platen the cleaning solution. With the help of a brush dissolve the most resistant and remote scale deposits in the platen.

11. Switch ON again the machine at front master button switch then push the PC BOARD PUSH BUTTON for more then 2" and less of 5" to put the machine in cleaning mode.

NOTE. *With the system in CLEANING/ RINSING mode the water pump is the only component in operation to circulate the cleaning solution in the entire water system.*

12. Let the unit to remain in the **CLEANING** mode for about 20 minutes then unplug again the machine.

NOTE. *The amount of Cleaner and the time needed for the cleaning of water system depends of the water conditions.*

13. Switch OFF the ice maker at master button switch then flush out the cleaning solution from the sump reservoir by taking off the sump plastic cup. Once flushed out install again the sump plastic cup.

14. Pour onto the evaporator cavity two or three liters of clean potable water to rinse the mold cups and the platen.

15. Switch ON again the machine. The water pump is again in operation to circulate the water in order to rinse the entire water system. Do the operation as per steps 13 and 14 twice so to be sure no more traces of descaling solution remains into the sump.

Sanitation

NOTE. *Sanitation of the water system is recommended to be done **once a month.***

16. Prepare in a plastic container the sanitation solution as per manufacturer dilution using warm water (45-50 °C).

NOTE. *Never mix the cleaning with the sanitising solution.*

17. Follow the procedures as per cleaning (from item 10 to item 13) just shorting the operation of the water pump to 10 minutes.

18. Place again the evaporator cover and the unit service panels.

19. At completion of the freezing and harvest cycle make sure of proper texture and clearness of the ice cubes and that, they do not have any acid taste.

ATTENTION. *In case the ice cubes are cloudy-white and have an acid taste, melt them immediately by pouring on them some warm water. This to prevent that somebody could use them.*

20. Wipe clean and rinse the inner surfaces of the storage bin.

REMEMBER. *To prevent the accumulation of undesirable bacteria it is necessary to sanitize every week the interior of the storage bin.*