

**SCOTSMAN**

**ICE SYSTEMS**

**CM 450 SL**

**Electronic Modular  
Cuber**

**With Purge Valve**

**Service Manual**

## **INTRODUCTION:**

This product manual contains the information needed for the setup, installation, initial start up, sanitation and maintenance of the ice machine model CM 450 SL.  
Keep it for future reference.

This manual is organized in the same way as the expected use of the machine, it begins with specifications, goes thru unpacking and setup, shows where everything is; continues with initial start up, then describes how it works. After that is the sanitation section, followed by service diagnosis and repair.

## **Table of contents:**

Introduction .....	Page 1
Table of Contents .....	1
Specifications .....	2
Pre-Installation .....	2
Location & Assembly .....	3
Plumbing .....	3
Electrical .....	3
After Utility Connections .....	3
Final Check List .....	3
Component Location and Function .....	4
System Controller .....	5
Initial Start Up .....	6
Adjustment .....	7
How to Operate the System Controller .....	8
How the Electronic Cuber Works .....	9-10
Freeze Cycle Operation Sequence .....	11
Harvest Cycle Operation Sequence .....	12
Sanitation and Cleaning .....	13
Additional Maintenance:	
Water Distributors .....	14
Bin Controls .....	15
Condenser .....	15
Operational Characteristics .....	15
Service Diagnosis: Controller Diagnostic Light Analysis .....	16
Service Diagnosis .....	17-18
Removal and Replacement	
Inlet Water Valve .....	19
Air Filter .....	19
Water Pump .....	19
System Controller .....	19
Electric Eyes (Bin Control Sensors) .....	19
Float Stem .....	20
Water Level Sensor .....	20
Water Temperature Sensor .....	20
Fan Blade and/or Fan Motor .....	20
Transformer/Contactor .....	20
Discharge Line Temperature Sensor .....	21
Refrigeration System Components .....	22
Liquid Charging .....	22
Wiring diagram .....	23

## Specifications:

This ice machine is designed to be installed indoors, in a controlled environment. It can operate satisfactorily under a wide variety of conditions. However, Do NOT operate the machine where it has not been designed for. Do NOT operate the machine in temperatures it has not been designed for. Do NOT operate the machine above or below the voltage limits for the particular model. Do NOT operate the machine with too little or too much water pressure.

### Operational Limits

	Minimum	Maximum
Air Temperature	10°C - 50°F	40°C - 100°F
Water Temperature	5°C - 40°F	40°C - 100°F
Water Pressure	1 bar (20 psi)	5 bar (80 psi)
Voltage (50 Hz model)	207	253

All models will fit a standard 560 mm (22") wide Scotsman Ice Storage Bin. Some examples are:

- SLB 260; SLB 375

In addition, there may be other bins that can be used, check Scotsman's sales literature for application information.

Note: This machine fill the bin very full, up to the base of the ice machine.

Scotsman reserves the right to make design changes and/or improvements at any time. Specifications and designs are subject to change without notice.

Scotsman assumes no liability or responsibility of any kind for products manufactured by Scotsman that have been altered in any way, including the use of any parts and/or other components not specifically approved by Scotsman.

## TECHNICAL SPECIFICATIONS

MODEL	DIMENSIONS			VOLTAGE	REFR. CHARGE R404A	ELEC. CONS. KWH/24 H
	W	MM D	H			
CM450SLA	560	597	696	220-240	850 gr	30
CM450SLW	560	597	696	220-240		30

## Pre-Installation:

Check the nameplate for electrical requirements. The nameplate is located on the back of the ice machine.

### Water:

There is no such thing as pure water. All water contains some impurities. There are two ways water carries the impurities: suspended and dissolved. Suspended solids can be filtered out. Dissolved solids must be diluted or treated. Water filters are recommended to remove suspended solids. Some filters have treatment in them for suspended solids. Check with a water treatment service for a recommendation.

Cube Ice machines use more water than what ends up in the bin as ice. While most water is used during ice making, a portion is designed to "rinse" out the water system to keep hard water scale from clogging up the machine. That water rinse, combined with water filters, prolongs the times between needed water system cleaning.

**Service Technicians:** All models covered here come set from the factory at a "standard" water rinse, which is compatible with typical water conditions. They may be adjusted to "Minimum" or "Maximum" water rinse after start up. If the prior ice machine worked acceptably well with the local water conditions, leave the machine at the factory setting. If severe water conditions are present, and water filters do not solve the problem acceptably, adjust the machine to use more water. If water conditions are excellent, adjust the machine to use less water. See the Adjustments section.

Note: Water use adjustments are customer convenience adjustments; they are NOT factory defects and are NOT covered by warranty.

## ICE MAKING CAPACITY (KG/24 HRS)

### AIR COOLED MODELS

AMB/WATER	32°C	21°C	15°C	10°C
10°C	200	220	230	245
21°C	185	200	210	215
32°C	155	170	175	180
38°C	140	155	160	165

## **Location & Assembly:**

The air cooled models take room temperature air in from the back and discharge warm air out the left and right sides. If installed in a corner or with another cabinet next to the right side, an air baffle could be installed on the back of the cabinet to minimize air re-circulation.

A 15 mm (6 inch) minimum clearance on the back, left and right sides is required for the proper operation and service of this machine.

### **Unpacking and Assembly:**

Begin with unpacking the ice storage bin. Remove the carton, and using part of the carton as a cushion, tip the bin on its back to remove the skid and attach the legs.

Return the bin to an upright position. Check the bin top gasket for gaps and tears, fill any in with food grade sealant prior to placing the ice machine on the bin.

If the ice machine has not been unpacked, do so now. Remove the carton from the skid. Lift the ice machine off the skid directly onto the bin.

**Note:** The machine is heavy! Use a mechanical hoist if necessary.

Secure the ice machine to the bin with the hardware provided (two metal straps and 4 bolts).

### **Cabinet Panel Removal:**

1. Remove the top/front panel by removing the two thumb screws located on the upper rear side and lift till to release it from the front bottom tabs.
2. Remove the 4 screws of each side panel and remove it from the unit frame.

## **Plumbing:**

All models require an adequate potable water supply and a gravity drain. The recommendations for tubing are: Water supply to 3/8" OD. Drain to be 3/4" OD.

### **Supply:**

Air cooled models have 1 water supply connection, a 3/4" GAS male at the back of the cabinet. Water cooled models have an additional 3/4" GAS male condenser inlet connection at the back of the cabinet.

### **Drain:**

Air cooled models have 1 gravity drain connection, a 20 mm O.D. male fitting at the back of the cabinet. It must be vented at the back of the cabinet.

Water cooled models have an additional condenser drain, it is a 3/4" GAS male fitting at the back of the cabinet. Do not vent this drain.

The ice storage bin have a 1" GAS female drain fitting out on its base.

Insulation is recommended for the ice machine reservoir and bin drains.

**Follow all applicable codes**

## **Electrical:**

All SCOTSMAN ice machines are supplied from the factory completely pre-wired and require only electrical power connections to the wire cord provided at rear of the unit.

Make sure that the ice machine is connected to its own circuit and individually fused (see data plate for fuse size).

The maximum allowable voltage variation should not exceed -10% and + 10% of the data plate rating. Low voltage can cause faulty functioning and may be responsible for serious damage to the overload switch and motor windings.

**NOTE:** All external wiring should conform to national, state and local standards and regulations.

Check voltage on the line and the ice maker's data plate before connecting the unit.

## **After Utility Connections:**

1. Level the cabinet, use the leg levelers on the end of the legs to adjust the cabinet height.
2. Wash out the bin. If desired, the interior of the bin could be sanitized.
3. Locate the ice scoop (if supplied) and have it available for use when needed.

### **Final Check List:**

1. Is the unit located indoors in a controlled environment?
2. Is the unit located where it can receive adequate cooling air?
3. Has the correct electrical power been supplied to the machine?
4. Have all the water supply connections been made?
5. Have all the drain connections been made?
6. Has the unit been leveled?
7. Have all unpacking materials been removed?
8. Is the water pressure adequate?
9. Have the drain connections been checked for leaks?
10. Has the bin interior been wiped clean or sanitized?
11. Have any water filter cartridges been replaced?

## **Component Location and Function:**

**Reservoir:** Contains the water charge used for every batch of ice.

**Water Inlet Valve:** Opens to allow water into the reservoir.

**Purge Valve:** Opens during the first part of harvest, when the water pump restarts the water in the reservoir is diverted to the drain.

**Water Level Sensor:** Controls the size of the ice cube by measuring how much water is used in a cycle. It consists of a float, stem and electric eye. The stem will move slightly when the pump is on, this is normal. As the machine makes ice the reservoir water level will fall and the visible portion of the stem will slide down thru the slot in the sensor body.

**System Controller:** Controls the complete operation of the ice machine. Turns it on and off; switches it between cycles; shows information via indicator lights; and shuts the machine down if there is a problem.

**Evaporators/Freezing Compartment:** Location of the CM Deep Cell Evaporators. Ice forms on the evaporators and is released when warmed up during the harvest cycle. The freezing compartment is fully insulated for maximum efficiency.

**Cube Deflector:** The slots in the inclined deflector let the water falling from the evaporators back into the reservoir, but when ice falls during harvest, the ice slides off into the bin.

**Refrigeration Service Access Valves:** Only to be used by a certified technician. Allows access to the refrigeration system for diagnostic information.

**Water Pump:** Forces the water from the reservoir to the top of the evaporator(s). The motor is separated from the reservoir water to minimize contact with the water.

**Compressor:** The refrigerant vapor pump, it forces the refrigerant to flow thru the refrigeration system tubing.

**Hot Gas Valve:** Closed during freeze, it opens during harvest to divert hot discharge refrigerant gas into the inlet of the evaporators.

**Condenser:** Either air or water cooled, discharges the heat produced in ice making.

## System Controller:

### Indicator Lights:

- **Bin Full:** ON when bin is full, goes ON and OFF as ice falls during a harvest cycle.
- **Freeze:** ON when the unit is in the Freeze cycle, blinks when a freeze mode is pending.
- **Harvest:** ON when the unit is in the Harvest cycle.
- **Clean:** ON when the unit is in the Clean cycle, blinks when preparing for a clean mode.
- **OFF:** ON when the unit has been switched OFF, blinks when the machine is preparing to shut OFF.
- **Water Error:** ON when the controller has identified a problem with the water system.
- **Refrigeration Error:** ON when the controller has identified a problem with the refrigeration system.

### Cycle Definitions:

- **Freeze:** The refrigeration system is operating to remove heat from the evaporators. The compressor, fan motor (if air cooled) and water pump are ON.
- **Harvest:** The refrigeration and water systems are operating to harvest the ice cubes. While the compressor is on for the full cycle, the water pump will be off at the beginning and inlet water valve will switch off before the end.
- **Clean:** The Inlet Water Valve opens to fill the reservoir, The Water Pump starts. The Clean indicator light is switched ON. A manually initiated rinse flushes the system.

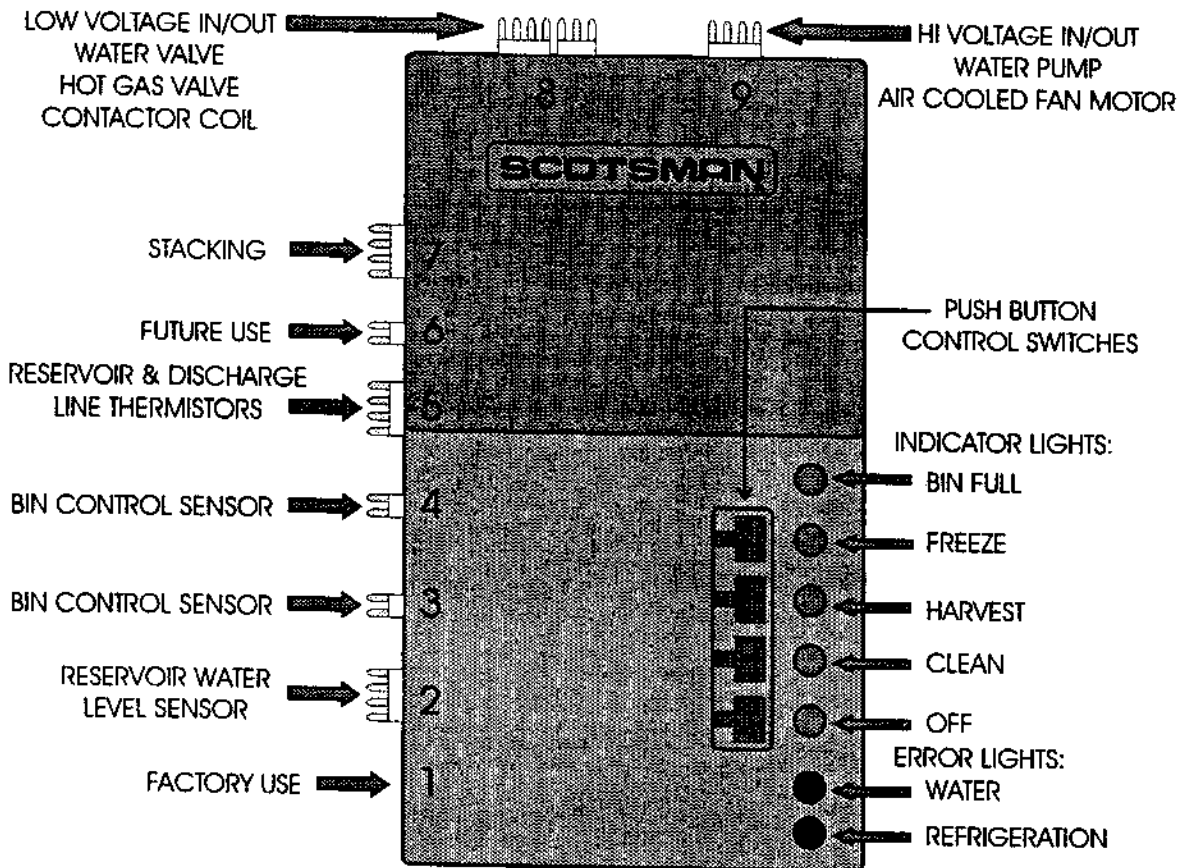

**System Controller: Wire Connections, Push Buttons, and Indicator Lights**

## **Initial Start Up:**

1. Remove the top/front panel.
2. Locate the System Controller.
3. Switch on the electrical power. Note that the LED or indicator lights all flashed on briefly.
4. Open the water supply valve.
5. Push and release the Freeze cycle push button (the Freeze indicator light will blink until the compressor starts). The next several operations are automatic.

### **Initial Start (30 seconds)**

- The Freeze light will begin to blink.
- The Hot Gas Solenoid valve will be open.
- The purge valve will be open.
- The water pump will be on.
- After 30 seconds, the hot gas valve closes.
- The purge valve will shut and the inlet water valve will open to fill the reservoir.
- The compressor starts.

### **Freeze Cycle:**

- The Freeze indicator light will come ON. The machine will stay in a Freeze cycle for many minutes. Slush may appear in the reservoir, it is temporary and normal.
- Under certain conditions, the pump may stop for a few seconds.
- The fan motor (of air cooled models) will begin to turn and soon warm air will be forced out the back of the cabinet.
- The freeze cycle will continue until the water level in the reservoir drops to its factory set point, then the Harvest Cycle will begin.

### **Harvest Cycle:**

- The Harvest indicator light will be ON.
- The hot gas valve will open.
- The purge valve will be open for 40 seconds.
- The water pump is stop, it will restart in < 40 seconds.
- The purge valve closes.
- The Inlet water valve will open for a short time.
- The Bin Full indicator light will go on and off as ice falls from the evaporators.

6. Machines are shipped from the factory with the purge level set to accommodate average water conditions. To achieve optimal machine performance, set the purge level to the minimum setting.

**Note:** While the amount of water purge is adjustable, only those installations with a water supply known to be excellent (very soft) should adjust to the minimum setting. See page 17 for purge adjustment instructions.

7. The machine's correct cube size should result in ice falling from the evaporator in vertical strips of 8 - 10 cubes; the top 2 cubes might fall individually.

8. After about 6 minutes (first cycle after any restart) the machine will return to a freeze cycle.

**Note:** After the first harvest, the controller will adjust the harvest time as needed to release all ice.

9. The reservoir refills at the beginning of Freeze.

10. Fill out the Customer Evaluation and Warranty Registration. Send it to Scotsman Europe.

11. Return all panels to their normal position.

12. Inform the user of the location and telephone number of the local service company. Also inform the user of the required maintenance of the machine.

### **Notes On Operation:**

1. The electric eyes signal the ice machine to shut off whenever the bin becomes full. After the eyes sense that there is ice between them, the ice machine will shut off at the end of the next harvest cycle. This last harvest cycle will be about 5 minutes long.

2. After the bin has filled the ice machine will not be able to restart for 4 minutes. However, if needed, the Freeze button may be pushed and the unit will restart.

For example: If ice is removed from the bin immediately after the machine has filled up and shut off, the machine will not restart for 4 minutes.

3. If the bin controls sense a bin full signal before any water is used (float stem up), the machine will shut off on bin full.

## Adjustments:

### If there was a problem during Initial Start Up:

If an error light came on, check the following.

#### 1. Water error.

A water error could have been determined by the System Controller if the inlet water valve does not fill the reservoir, or if the water pump does not start and lower the water level.

#### 2. Refrigeration error.

A refrigeration error could have been determined by the System Controller if the water temperature did not drop during the freeze cycle. The controller will next check the compressor discharge temperature. If the discharge temperature is too low, the refrigerant error light will be switched on, and the machine will Shut Down.

**Note: Reset and restart the machine by pushing and releasing the OFF push button switch, and then pushing and releasing the freeze push button switch.**

### How to adjust the water cooled discharge pressure

Water cooled models use a water regulating valve to control how much cooling water flows thru the water cooled condenser. At the top of that valve, located in the right rear corner of the ice machine, is an adjustment stem.

To Adjust:

1. Attach a refrigeration manifold gage to the discharge access valve.
2. While the unit is in the freeze cycle, determine the discharge pressure, it should be about 17.5 bar (245 PSIG).
3. If needed, rotate the adjustment stem to increase or decrease the pressure:

A. To increase discharge pressure (reduce water flow) rotate the stem counter-clockwise.

B. To decrease the discharge pressure (increase water flow) rotate the stem clockwise.

Remove the manifold when done.

**Note: The water outlet temperature should be between 40-45°C (100-110°F) when the valve is properly set.**

### Thermostatic Expansion Valve:

The TXV is adjustable so to control the flow of refrigerant into the evaporators serpentine. Adjustment of TXV is required in order to have the correct ice formation on the evaporators surfaces. Refrigerant enters on the bottom and leaves from the top. When ice is too thin on the upper part of the evaporators the TXV needs to be open turning its adjusting stem counterclockwise by a quarter turn.

### How to Adjust the Amount of Water Purge

Adjustment is done by use of the control buttons on the System Controller. Examine the next section to become familiar with the System Controller before beginning.

1. If the machine is ON, push and hold the OFF button for more than 3 seconds, then release it. This switches the machine OFF.

2. Push and hold the OFF button for more than 3 seconds (just until all LEDs flash on) then release it. Do not hold it in it too long.

3. Examine the green LEDs. They should have all flashed once, then certain ones will have turned on to indicate which purge level the machine is set at. There are 5 levels of purge available:

- 1. **Maximum Purge** is when ALL lights are ON. Use for extreme water conditions. Note: This setting may extend the Harvest cycle and reduce capacity.
- 2. **Heavy Purge** is when these 4 lights are ON: Freeze, Harvest, Clean, OFF. Use for severe water conditions.
- 3. **Standard Purge** (factory setting) is when these 3 lights are ON: Harvest, Clean, OFF. Use for moderate to severe water conditions.
- 4. **Moderate Purge** is when these 2 lights are ON: Clean, OFF. This is for typical water conditions.
- 5. **Minimum Purge** is when this light is ON: OFF. For excellent water conditions.

Adjust by pushing and releasing the Freeze button. Pushing and releasing the Freeze button increases the purge one level up to the maximum, then it goes to the minimum.

4. The machine will automatically restart after 60 seconds of no switch inputs, or restart the machine by pushing in and holding the OFF button for more than 3 seconds, then releasing it. The unit will then be OFF. From there the machine may be placed in a freeze cycle by pushing and releasing the Freeze button.

# How To Operate The System Controller

The System Controller is a microprocessor based device that receives input from several sources and switches various components ON and OFF.

Its manual control is thru the use of the Push Button Control Switches

1. **Freeze Button.** Pushing and releasing this button starts or restarts the machine. The System Controller remembers what cycle it was last in and returns to that cycle.

2. **Harvest Button:** Pushing and releasing this button will cause the machine to go directly to a Harvest Cycle. Can be done from Freeze or Off. The machine will switch Off at the end of the Harvest cycle.

3. **Clean Button:** Pushing and releasing this button will cause the machine to only power the water pump for circulation of ice machine cleaner. After the ice machine cleaner has circulated for about 10 minutes a second push of this button will switch on the rinsing system to flush out the dissolved scale and ice machine cleaner.

4. **OFF Button:** Pushing and releasing this button will switch the machine OFF at the end of the next cycle. If the button is pushed and HELD for more than 3 seconds, the unit will switch OFF immediately.

**To Reset Machine (machine OFF, error light ON):** First push and release the OFF button, then push and release the Freeze button.

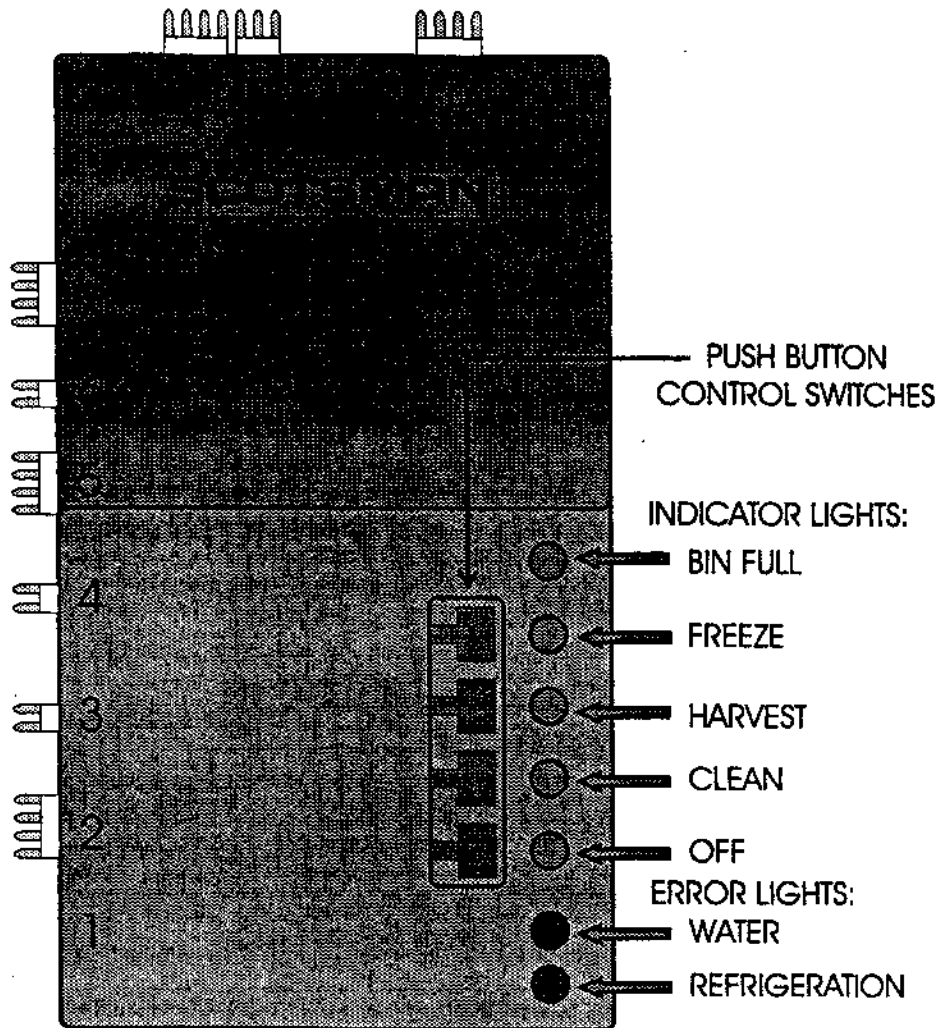

**System Controller Indicator Light Description**

## How The Electronic Cuber Works

This section is intended for the technician. It is not necessary for the normal operation and maintenance of the machine.

**Freeze Cycle:** Heat is removed from the water and discharged out the condenser during the freeze cycle. As liquid refrigerant passes thru the Thermostatic Expansion Valve, it enters the bottom of the evaporators, and ice will form at the bottom first.

**Harvest:** When cubes need to be released the Hot Gas Valve is opened and Hot discharge gas flows directly from the compressor to the evaporator inlets.

This warms up the evaporators and the surface of the ice frozen to the evaporator surface melts. Ice then falls into the bin.

### **Water System:**

#### **Freeze:**

The water pump forces water to the top of the evaporators. The un-frozen water falls thru the cube deflectors and back into the reservoir. As water is turned into ice, the water level in the reservoir falls indicating to the System Controller that it is time to begin the Harvest cycle.

#### **Harvest:**

At the beginning of Harvest, the water pump shuts off and the purge valve opens. The purge valve remains open for 40 seconds. No water will drain until the water pump restarts. The water pump will start at a variable time depending upon the amount of water rinse that has been set. After the purge valve has closed, the inlet water valve opens and water flows into the ice machine. The water valve will NOT be open the complete length of the harvest cycle.

The inlet water valve will "top off" the reservoir at the beginning of the next freeze cycle.

The System Controller operates the ice machine by monitoring several input measures and switching various loads on and off.

### **Controller Inputs:**

1. **Reservoir water temperature.** This is measured by a thermistor located in the water pump outlet.
2. **Discharge line temperature.** This is measured by a thermistor located on the compressor discharge line.
3. **Water level.** This is measured by an infrared sensor and float. The float rises and falls with the water level, and switches the sensor ON and OFF as it moves.
4. **Bin fill level.** This is measured by a set of electric eyes in the cube outlet port. If ice fills the bin, it will block the "eyes".
5. **Time.** The controller measures and compares how long it takes for various events to happen. It stores that data for future reference.

### **Controller Outputs:**

#### **A. 24 volt:**

- 1. LEDs (lights)
- 2. Inlet water valve
- 3. Hot Gas Valve
- 4. Contactor Coil

#### **B. High Voltage (230V)**

- 1. Water Pump
- 2. Air cooled Fan Motor
- 3. Purge valve

## How The Electronic Cuber Works

This section is intended for the technician. It is not necessary for the normal operation and maintenance of the machine.

The System Controller operates the ice machine by monitoring several input measures and switching various loads on and off.

### **Water System:**

Water flows into the ice machine during the beginning of the freezing cycle thru the inlet water valve. The water pump forces water to the top of the evaporators mainly in the Freeze cycle. Un-frozen water falls thru the cube deflector and back into the reservoir. As water is turned into ice, the water level in the reservoir falls, and at the point where the cubes are fully formed, the Water Level Sensor indicates to the System Controller that it is time to begin the Harvest cycle.

During the Harvest cycle, water purge valve is energized for the first 40 seconds while the water pump operates according to the setting of the System Controller to drain out the water reach of accumulated minerals from the bottom of the water reservoir.

### **Refrigeration System:**

The refrigeration system is similar to that of most commercial cube ice machines. Heat is removed from the water and discharged out the condenser during the freeze cycle. As liquid refrigerant passes thru the Thermostatic Expansion Valve, it enters the bottom of the evaporators, and will form on the bottom first. When cubes need to be released (Harvest) the Hot Gas Bypass Valve is opened and hot discharge gas flows directly from the compressor to the evaporator inlets. This warms up the evaporators and the surface of the ice frozen to the evaporator surface melts. Ice then falls into the bin.

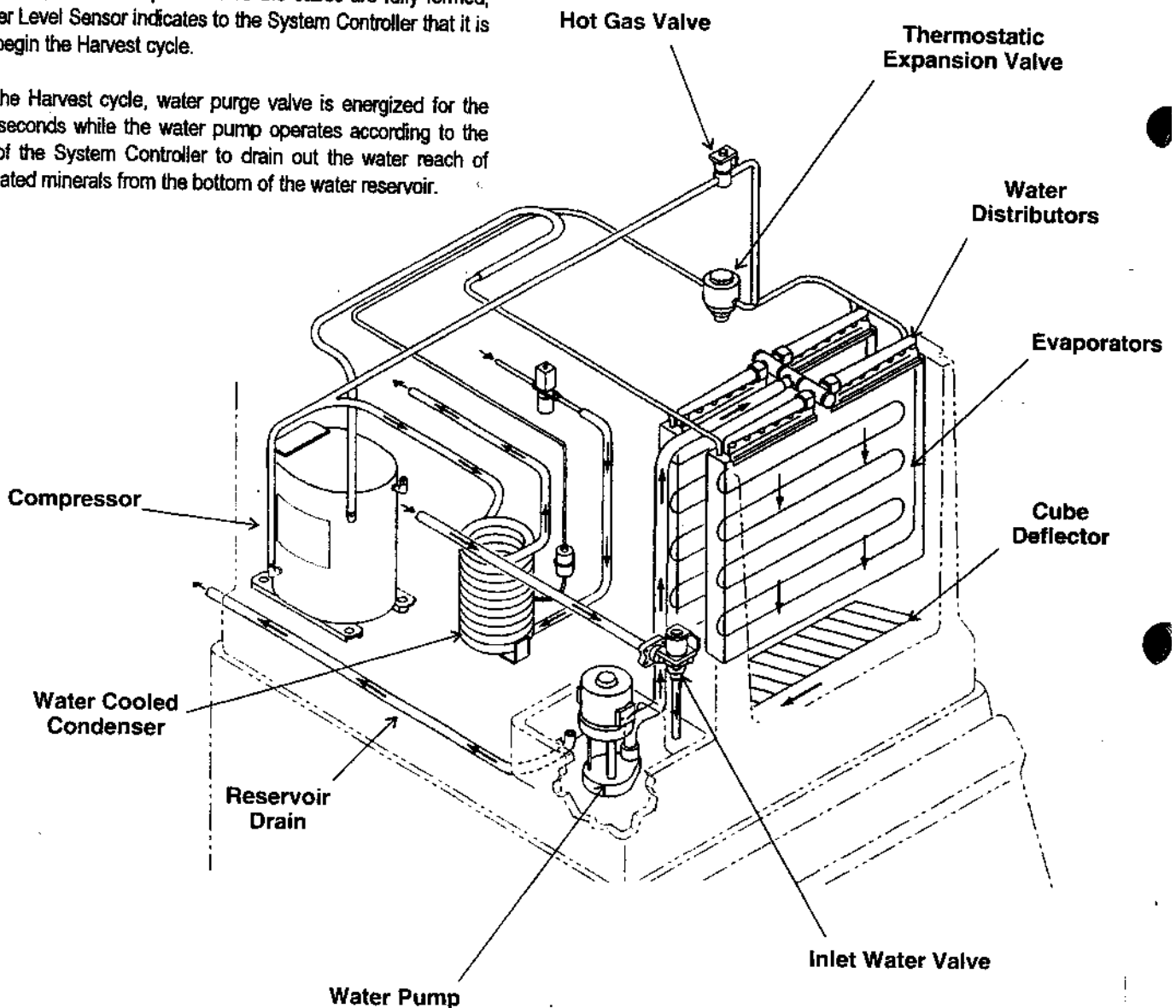

**Water and Refrigeration Schematic**

## **Freeze Cycle Operational Sequence**

Assuming the machine has been operational, the Freeze cycle begins with the end of the Harvest Cycle:

- Water Inlet Valve is Closed
- Water Pump is ON
- Compressor is ON
- Hot Gas Valve is Open

### **System Controller Operation, Beginning freeze:**

1. Switches on the Freeze indicator light and shuts off the hot gas valve.
2. Opens the water valve to top off the reservoir. The controller checks that water fills the reservoir, if it does not fill up within 250 seconds, the controller shuts the machine down. It will automatically try to restart in 20 minutes.
3. Measures and stores the discharge temperature.
4. Starts the fan motor (air cooled only). If the discharge temperature exceeds the design maximum, shuts the machine down on a Refrigerant Error.
5. Checks for a "bin full" signal throughout the cycle.
6. Measures the reservoir water temperature. If the machine is operating correctly, the reservoir water temperature will fall at a standard rate. The System Controller will be checking to see if the water temperature fall matches that rate.  
  
If not, it re-checks the discharge line temperature. If too low, it Shuts Down on a Refrigeration Error. If the discharge temperature is acceptable, the water system is checked by shutting off the water pump and determining if the water level goes up enough. If it does not, it is assumed that there is a water pump problem and the machine Shuts Down on a Water Error.  
  
If the water level does "measure up" the water pump is restarted and the System Controller then measures how long it takes to lower the water level. If the water level does not fall, the machine Shuts Down on a Water Error.
7. Once per freeze cycle the machine will shut off the water pump. It only does this when the water temperature reaches a preset minimum. The pump will only be off for a few seconds.
8. As the machine makes ice, the water level in the reservoir will ultimately fall to the Harvest Level (when the top electric eye in the water level sensor is disrupted by the upper side of the slot).

Note: If the freeze cycle exceeds the preset Maximum (50 minutes), the System Controller will Shut Down on a Refrigeration Error.

9. The end of Freeze cycle will see the machine in this state:

- Water level = below harvest position
- Water inlet valve will be OFF
- Water pump will be ON
- Compressor will be ON
- Hot gas valve will be OFF
- Condenser fan will be OFF

At this point Harvest begins and the System Controller switches the Harvest indicator light ON.

Restarts:

If the machine is restarting after it has shut off because the bin was full, the first freeze cycle sequence is like this:

1. Purge valve is open
2. Pump starts
3. Purge valve closes
4. Water valve opens to fill the reservoir
5. Compressor starts

Note: If there is a power interruption, the system controller will automatically restart the machine with a process that begins with getting the machine back to a normal state: the unit freezes for 30 seconds and then goes into a 6 minutes harvest. It will then proceed to a new Freeze cycle. While in an electrical restart mode, the controller's Freeze light will be blinking - even when the machine is in harvest.

**Error Restarts:**

The machine automatically attempts to restart 50 minutes after a shut down. If another problem occurs in the next cycle, the machine will attempt one more restart. If another problem occurs in the next cycle, the machine will shut off and must be manually reset.

# Harvest Cycle Operational Sequence

## Harvest

The Purge Valve will be open for 40 seconds.

The water pump shuts off, it will restart before 40 seconds. The restart time is based on the Purge Valve setting.

The pump restarts and pumps water out of the reservoir until the purge valve closes.

The inlet water valve will stay on for about 10 seconds to add enough water to assist with the harvest.

The Hot Gas Valve will be open for the entire length of the Harvest Cycle.

During the Harvest Cycle, ice will be falling from the evaporators and between the bin control's electric eyes. The System Controller monitors how long the ice falls and uses that time to determine the next harvest cycle's length.

The first Harvest after a restart will take about 6 minutes to establish a base line, then the time it took to release that ice is used to determine the next harvest cycle's length.

The maximum harvest time is 14 minutes.

If no cubes fall (or are sensed) by the end of the Maximum Harvest Time, the machine senses a Refrigerant error. If the next cycle also produces a Refrigerant error, the machine will shut down.

Note: The last Harvest cycle before shutting off on Bin Full will be 6 minutes long.

Note: The machine will not restart for 4 minutes after switching off on Bin Full, unless the freeze button is pressed.

## Diagnostic Lights and Manual Resets

The controller will shut the machine off if a malfunction is sensed. The controller will restart the machine 2 times, with a 50 minute interval between restarts.

If a malfunction is still present after the second restart, the machine will then shut off and must be manually reset. During the restart interval, the machine will be off and a diagnostic code indicated.

An exception to this is lack of water. When switched off because of lack of water, the machine will always try to re-fill the reservoir every 20 minutes.

Another exception is a harvest error. As before, there must be two consecutive harvest errors to trigger a machine shut-down. With this change, the controller will still shut down and restart the machine after two consecutive harvest errors. However, if the errors repeat two more consecutive times, the controller will shut down and restart the machine again. If the machine registers two more consecutive harvest errors, the machine will again shut down and must be manually reset.

## Diagnostic Light Code Table

If a Diagnostic Light	Water Light	Refrigeration Light
Blinks once and repeat	Water pump will not start	Very long ice harvest
Blinks twice and repeats	Lack of water fill	No harvest of ice
Blinks three times and repeats	Not used	High Discharge Temperature
Is ON all the time	Water valve leaking thru rapidly	Check for low discharge temperature or long freeze cycle
Both ON all the time	Check for thermistor set unplugged or failed	Check for thermistor set unplugged or failed

## Sanitation and Cleaning

It is the User's responsibility to keep the ice machine and ice storage bin in a sanitary condition. Without human intervention, sanitation will not be maintained. Ice machines also require occasional cleaning of their water systems with a specifically designed chemical. This chemical dissolves mineral build up that forms during the ice making process.

Sanitize the ice storage bin as frequently as local health codes require, and every time the ice machine is cleaned and sanitized.

The ice machine's water system should be cleaned and sanitized a minimum of twice per year.

### In Place Cleaning of the Ice Machine Water System:

1. Remove all ice from the bin. Either save it in a sanitary container or discard it. If the cleaning was planned, the ice machine could be switched off the night before to minimize waste.
2. Remove the top/front panel.
3. Push and release the Harvest button (this releases any ice that may be on the evaporators and warms them up).
4. Wait for the machine to finish the Harvest cycle (the machine will stop).
5. Unloose the two thumb screws holding the water pump/water level control assy and hook it to the two screws placed on the upper left side.
6. Pour 350 cc (12 ounces) of Scotsman Ice Machine Cleaner into the water sump then refit the water pump/water level control assy to its normal installed position.

**WARNING - SCOTSMAN Ice Machine Cleaner contains Phosphoric and Hydroxyacetic acids. These compounds are corrosive and may cause burns if swallowed. DO NOT induce vomiting. Give large amounts of water or milk. Call physician immediately. In case of external contact, flush with water. KEEP OUT OF THE REACH OF CHILDREN.**

7. Push and release the Clean button. The Clean indicator light will be blinking, and the pump will restart.
8. After the ice machine cleaner has circulated for 10 minutes, push and release the Clean button. This starts the rinsing process. The Clean indicator light will be ON.

Note: The rinse process flushes any residual cleaner out of the ice machine's water system.

9. Continue the rinsing process for 20 minutes, then push the off button to switch the machine off.
10. Unloose the two thumb screws holding the water pump/water level control assy and hook it to the two screws placed on the upper left side.

11. Remove from the upper side of the machine the evaporator front covers then remove the cube deflector from the upper side of the sump.

12. Pull out the water sump from the front of the machine then place it with the cube deflector in a separate container.

13. Mix a solution of 250 cc (8 ounces) of Scotsman ice machine cleaner and 4 liters (1 gallon) of warm (40+50°C - 95+115°F.) water. Use the solution to scrub the water sump and cube deflector in the separate container.

14. Go to the next step to sanitize the machine

15. Prepare a Sanitizer solution. Follow local codes for Sanitizer.

Note: A possible sanitizing solution may be made by mixing 1 ounce of liquid household bleach with 2 gallons of warm (40+50°C - 95+115°F.) potable water.

16. Refit the water sump, the cubes deflector and the water pump/water level control assy to its normal installed position as well as the evaporator front cover.

17. Push and release the Clean button again.

18. Pour 16 ounces of Sanitizer solution into the reservoir water.

19. After the solution has circulated for 10 minutes push and release the Clean button. This starts the rinse process. Sanitize the ice storage bin while waiting.

20. Continue the rinsing process for 20 minutes, then push the off button to switch the machine off.

21. Push and release the Freeze button.

22. Return the front/top panel to its normal position and secure it to the machine with the screws.

## To Sanitize the Ice Storage Bin

1. Remove all ice.

2. Remove baffle.

3. Switch ice machine OFF.

4. Mix a 1 gallon solution of warm (40+50°C - 95+115°F.) water and sanitizer. Follow local codes for sanitizer.

5. Wash or spray the entire interior of the ice storage bin with the sanitizer solution. This includes the bottom of the ice machine and the inside of the door, the door gaskets (if any) and door frame.

6. Pour excess sanitizer into the bin to flush the drain system.

7. If the approved sanitizer requires a rinse, rinse all interior surfaces with potable water.

## **Additional Maintenance: Water Distributors**

It may become necessary to remove the water distributors from the top of the evaporator and clean (de-mineralize) them outside of the ice machine.

1. Remove top/front panels.
2. Push and release the OFF button.
3. Remove the evaporator covers.
4. Reach over the water distributors and pull the hose off.
5. Push the two water distributors to the right until the left end clears its retaining slot, then pull the left end up.
6. Repeat for the back evaporator.

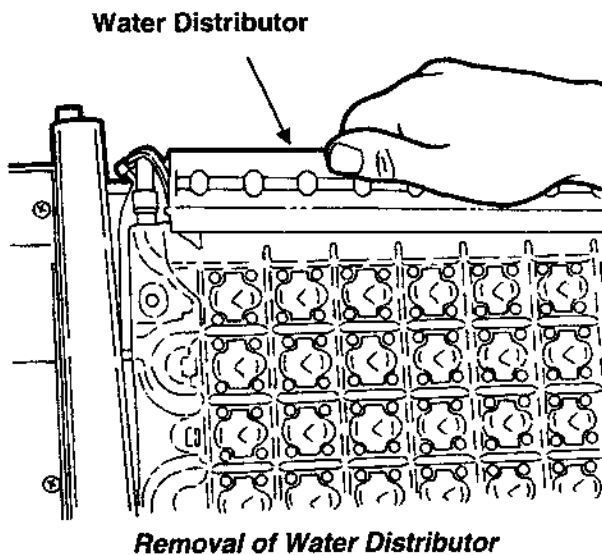

7. Examine the top of the evaporators. The Water Distribution Channels must be free from mineral build up. If build up is evident, scrub the channels with Scotsman Ice Machine Cleaner and a plastic bristle brush.

8. Examine the water distributors. Although they are made of a material that is resistant to mineral build up, some may be present. Soak or scrub the distributors in or with a solution of Scotsman Ice Machine Cleaner and warm potable water.

9. Return the water distributors to their normal installed position.

9a. Snap the two distributors onto the water manifold. Place them on the back evaporator, right end first. Push the distributors far enough to the right until the left end clears the retaining slot, then release. Check that the distributors are seated properly.

9b. Place the water hose onto the back water distributors.

9c. Repeat for the front evaporator.

10. Push and release the clean button to flush the water system.

11. After the machine stops, push and release the Freeze button.

12. Replace the evaporator covers.

13. Replace the top/front panels.

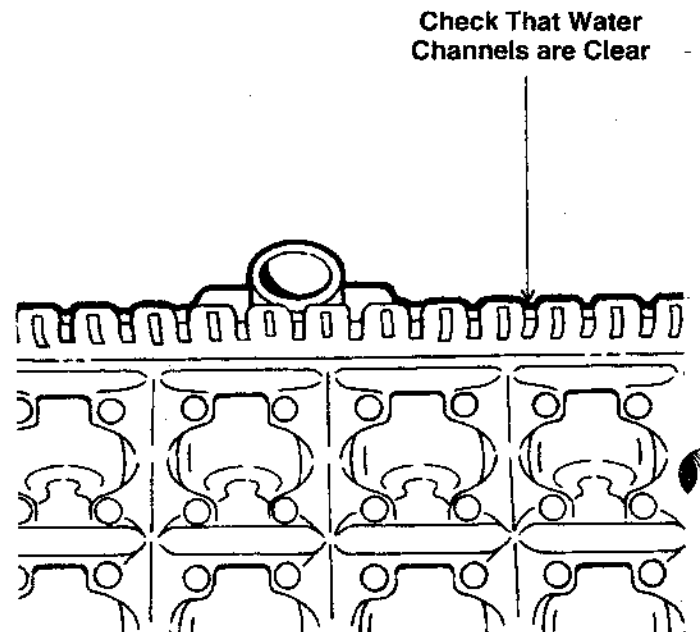

## **Additional Maintenance: Bin Controls, Condenser**

The bin controls use a system of infrared emitting and receiving components to sense the build up of ice in the bin. They are located at the bottom of the ice outlet port. They must be free of mineral build up to function properly. To check:

1. Remove top/front panels.
2. Push and release the off button.
3. Remove left and right side panels.
4. Remove the evaporator covers.
5. Remove the cube deflector.
6. Remove the water sump.
7. Remove the screws securing the metal shield first then the optical ice level control from the two sides of the unit base.
8. Examine the bottom of the optical ice level controls. There are two sensors in each one. Check that they are clear of mineral build up. They may be wiped clean with ice machine cleaner to assist in removal of the build up.

Note: Do NOT use abrasive materials or cleaner on the bin sensor lenses. A soft toothbrush is an effective tool for cleaning these sensors.

### **Air Filter Replacement**

1. Simply withdraw from its sliding frame the Air Filter from the top/right back side of the unit for replacement/cleaning.

### **To Clean the Air Cooled Condenser**

1. Remove the top/front panels.
2. Push and release the Off button.
3. Remove the right and left side panels.
4. Check the fan blade and condenser for grease or dust build up.
5. Clean or replace the air filter.

Because air flow is from the back of the cabinet in, the outside of the condenser fins will have the most build up.

- A. Place the inlet hose of a vacuum cleaner in the condenser.

- B. While the vacuum cleaner is on, blow air from the inside of the condenser thru the fins.

- C. If grease is present, use coil cleaner on the condenser. Be sure to wipe up any excess coil cleaner.

6. Replace the left and right side panels.

7. Push and release the Freeze button.

8. Replace the top/front panels.

## **Operational Characteristics:** (at 21°C ambient and 15°C water)

Average Cycle Time:..... 18' 45"  
 Average Freeze time:..... 16' 30"  
 Average Harvest time:..... 2' 20"

## **System Pressures:**

### **Air cooled**

Discharge pressure (beginning freezing):..... 19 bar (265 PSI)  
 Discharge pressure (end freezing):..... 16.5 bar (230 PSI)

Suction pressure (beginning freezing):..... 4.5 bar (65 PSI)  
 Suction pressure (end freezing):..... 2.2 bar (31 PSI)

### **Water cooled**

Discharge pressure:.....

Suction pressure (beginning freezing):.....

Suction pressure (end freezing):.....

### **Typical Compressor Amps**

Beginning freezing:..... 6.0 A

End freezing..... 4.0 A

### **Refrigerant Charge, R-404A**

Air cooled:..... 850 gr

Water cooled:..... gr

### **Typical Harvest Ice Weight**

3 - 3.2 Kg (6.5 - 7 lb.)

## Service Diagnosis: Controller Diagnostic Light Analysis

Problem or Symptom	Possible Cause	Probable Correction
Machine is OFF	Bin is full, ice in cube port	Use some ice
	Power is OFF, check LED's	If all LEDs are out, check power supply, restore power if OFF
	Transformer is open	If all LEDs are out and there is power, check transformer output for 24 VAC
	Unit has been switched OFF OFF light is glowing	Push and release Freeze button to restart unit
	Compressor will not start	Not enough water or water not sensed
	Unit has Shut Down	Check for Refrigeration or Water Error
Unit is OFF & Water diagnostic light is ON or BLINKING	Water pump malfunction	Check water diagnostic light, if blinks onc and repeats. Water pump or hose off
	Water inlet valve malfunction	Check water diagnostic light, if it blinks 2 times and repeats. Slow or no water fill or low water level
	Water inlet valve malfunction	Check water diagnostic light, if ON without blinking. The inlet water valve ma be leaking thru rapidly
Unit is OFF & Refrigeration diagnostic light is ON or BLINKING	Low discharge or long freeze cycle	If the Refrigeration light is glowing steadily. Low discharge temperature or a maximum length freeze cycle was used
	Harvest problem	If the Refrigeration light blinks once and repeats. Maximum length harvest cycle used to release ice
	Hot gas valve failure	Check hot gas valve operation
	High discharge temperature	If the refrigeration diagnostic light blinks 3 times and repeats. High discahrge temperatures
	Harvest problem	If the light blinks 2 times and repeats. Maximum length harvest cycle use, no ice sensed
	Unit doesn't go into harvest-exceeds maximum freeze time	Push and release OFF button. Push and release Freeze button. Check operation  Push cube size float down and check operation
	Exceeds maximum harvest time	Check for cause of long harvest cycle
Unit runs and both Diagnostic lights are ON	Temperature sensors out of range	Replace the temperature sensor set (wate and discharge)
Same but 1 light is ON	Reservoir temperature wrong	Reset and check water temp. and sensor

Problem or Symptom	Possible Cause	Probable Correction
Unit is OFF because of a Harvest Problem	Bin controls did not sense ice falling, unit stayed in harvest until the maximum harvest time run out	Check bin controls. The bin full light should be OFF. If it is ON or BLINKING the bin controls may be dirty. Clean if dirty. The board and bin controls may also need to be checked.  Push and release OFF button. Push and release Freeze button. Check machine operation. Check if ice is made and harvest
	Bin controls or System Controller may have failed	See "Unit doesn't shut OFF" below...
	Other components may have failed	Check the next page
Cubes are too large	Cube size control float is sticking	Check/clean
Cubes are too small	Not enough water	Check for leak in reservoir
Low ice capacity	Dirty condenser or filter	Replace filter, clean condenser
	Recirculation of air	Block air re-circulation or move machine
	Low refrigerant charge	Check system. If there is a low charge, find the leak, recover the refrigerant, repair the leak, replace the dryer, evacuate and weigh in the nameplate charge
Unit does not shut off	Bin control system may have failed	Check bin controls. Check bin full light, if off, place something between the electric eyes. The bin full light should begin to blink (after 20 seconds of continuous blockage it will glow steadily). If not, check operation of electric eyes by unplugging # 4 and jumping out the two pins on the controller (first discharge any static electricity by touching the cabinet with the tool). If the bin full light blinks, replace the bin controls. If it doesn't blink, replace the controller. Note: Leaving # 4 unplugged and jumped for 20 seconds will shut the machine down on a bin full (at the end of the harvest cycle). It will restart after 4 minutes or may be reset by pushing the Freeze button

Problem or Symptom	Possible Cause	Probable Correction
Fan motor doesn't turn. Refrigeration light may be ON steadily or blinks 3 times and repeats	Open motor windings or seized bearings	Replace fan motor
	No power to fan motor	Fan motor unplugged, check for voltage from controller. If none, replace controller
Pump motor doesn't turn	Open motor windings or seized bearings	Replace pump
	No power to pump	Check electrical connections. If the unit is in Freeze, Clean or Harvest the pump should have power to it. If not replace the System Controller
Hot gas valve doesn't open	Open solenoid coil	Replace hot gas valve
	Stuck valve	Replace hot gas valve
	No power to coil in Harvest	Check wire connections. If OK replace System Controller
Hot gas valve leaks thru (warm tube temperatures on both sides of the valve during freeze)	Mechanical problem in valve	Replace valve
Water inlet valve doesn't open	Open solenoid coil	Replace valve
	Stuck valve	Replace valve
	No power to valve (early part of harvest)	Check wire connections. If OK replace System Controller
Water inlet valve doesn't flow enough water	Restriction in water supply	Check water filters and/or inlet screen
Water inlet valve leaks thru	Mechanical problem in valve	Replace valve
Compressor doesn't work	Unit in Clean cycle	Push and release Freeze button
	Contactors coil open	Replace contactor
	Open starting components	Check and replace
	Open windings	Check and replace compressor
	Water level too low or not sensed	Unit must be full of water before controller will start compressor. Check water level and sensor and harness

## **Removal and Replacement**

### **Inlet Water Valve**

1. Remove the top/front panels.
2. Shut off the water supply.
3. Push and release the OFF button.
4. Disconnect the water inlet hose from the water inlet valve fitting.
5. Unloose the screw securing the metal plate of the water hook up to the rear of the machine frame.
6. Move the water hook up assy outside then unloose the clamp and disconnect the outlet tube.
7. Pull the wire harness off the inlet water valve.
8. Remove screws holding the inlet water valve to the metal plate and pull the valve away.
9. Reverse to reassemble paying attention to insert the water drain fitting into the water drain rubbertube.
10. Push and release the Freeze button.
11. Replace the top/front panel and reconnect the water inlet hose.

### **Air Filter Replacement**

1. Remove the top/front panels.
2. Push and release the Off button.
3. Slide up the air filter from its bracket.
4. Check the condenser for grease or dust build up. Clean as required.
5. Replace the air filter.
10. Push and release the Freeze button.
11. Return the top/front panels to their original position securing them with screws.

### **Water Pump**

1. Disconnect the electrical power.
2. Remove the top/front panels.

3. Unloose the two trumb screws securing the water pump/water level control assy to the unit frame.
4. Unloose the two screws securing the water pump meta protection to its bracket and remove it.
5. Unplug water pump from its electrical connection.
6. Disconnect the outlet tube.
7. Remove the screw securing the water pump to its bracket and pull it out.
8. Reverse to replace.
10. Replace top/front panels.
11. Re-connect electrical power.

### **Removal and Replacement: System Controller**

1. Disconnect the electrical power.
2. Remove the top/front panels.
3. Remove screws and the front cover of the control box.
4. Unloose the screw holding controller to cabinet.
5. Touch a metal surface to discharge any static electricity.
6. Pull controller out slightly and unplug all electrical connections.

**Note:** Do NOT touch the back of the controller.

7. Carefully remove the new controller from its packaging. Again, do NOT touch the back of the controller.
8. Plug all electrical connectors into the new controller.
9. Re-attach the controller to the cabinet.
10. Re-fit the front cover of the control box.
11. Switch on the electrical power. All LEDs should lite up.
12. Push and release the Freeze button.
13. Replace the top/front panels.

### **Electric Eyes (Bin Control Sensors)**

These must be replaced as a set.

1. Remove top/front panels.

2. Push and release the Off button.
3. Remove left and right side panels.
4. Unplug both from the System Controller (#3 and #4).
5. Remove the water pump/water level control assy.
6. Remove evaporator covers and cube deflector.
7. Unloose the screws holding the two metal shields then the screws securing the bin controls to the frame.
8. Pull them up from the unit base.
9. Reverse to reassemble paying attention to insert the bottom metal plate into the slot on each side of the freezing compartment.

#### **Removal and Replacement of Float Stem**

1. Remove top/front panels.
2. Push and hold the OFF button. Release it when the machine stops.
3. Unloose the two trumb screws and remove the water pump/water level sensor assy.
4. Unloose screws and remove the metal protection.
5. Lift the pump and mounting plate up enough to remove the float from the stem.
6. Pull up on float stem, reach under pump bracket and pull the float off the stem.
7. Pull stem out and reverse to replace.

#### **Removal and Replacement: Water Level Sensor**

1. Follow the Float Stem removal procedures first.
2. Trace wire harness from water level sensor to the System Controller (#2). Unplug the harness from the controller.
3. Push in the bottom of the pump mounting plate the two plastic hooks and remove the water level sensor.
4. Reverse to reassemble.

#### **Water Temperature Sensor**

Note: This sensor is replaced as a set with the Discharge Temperature Sensor.

1. Remove top/front panels.
2. Push and release Off button.
3. Remove left side panel.
4. From the upper side of the machine locate water temperature sensor (inserted into pump discharge hose).
5. Rise a little bit the pump discharge till to have the water temperature sensor out from the evaporator compartment then pull out to remove.
6. Trace back to system controller, unplug from #5.
7. Remove the Discharge Line temperature sensor (see the next page).
8. Reverse to reassemble.

#### **Removal and Replacement: Fan Blade and/or Fan Motor**

1. Disconnect electrical power.
2. Remove top/front and side panels.
3. Remove the screws securing the condenser to the cabinet and pull it out for few centimeters (a couple of inches).
4. Remove the 4 screws holding the fan motor bracket to the condenser shroud.
5. Unplug the fan motor.
6. Carefully remove the fan motor, blade and brackets from the ice machine cabinet.
7. Replace the motor or blade as needed.

#### **Removal and Replacement: Transformer/Contactor**

1. Disconnect electrical power.
2. Remove top/front panels.
3. Remove the screws securing the metal cover to the control box.
4. Disconnect the wires connected to the inlet (230V) and to the outlet (24V) to the transformer or the same to the contactor
5. Remove 2 screws and the transformer/contacter from the control box.
6. Reverse for the installation.

**Note:** The contactor coil is 24 volt.

7. Check operation of the components reconnecting to the electrical power.

**Note:** If the transformer is not supplying power, check the system controller for blacking at the top connections. If the connections appear to have blacked, replace the system controller before the transformer is replaced.

#### **Discharge Line Temperature Sensor**

**Note:** This sensor is replaced as a set with the Water Temperature Sensor.

1. Remove top/front panels, push and release the Off button.
2. Remove left side panel.
3. Locate discharge line sensor. It is attached to the discharge line of the compressor.
4. Un-snap the clip holding the sensor to the discharge line.
5. Trace the sensor wires back to the controller, they are plugged into #5 with the water temperature sensor, and must be replaced with it.
6. Reverse to replace, be sure that the discharge line sensor is 6" up from the compressor discharge port.

**Note:** Route wires so they do NOT contact the discharge line.

**Note.:** The sensor for the Discharge line is marked with a small piece of yellow tape. Do not reverse the sensors.

## **Refrigeration System Components**

Due to the expected level of training and experience of a refrigeration mechanic, detailed instructions regarding the replacement of refrigeration components will not be presented. However, critical items will be noted here.

### **Refrigerant:**

1. This ice machine uses R-404A or HP62 as a refrigerant. It has several unique characteristics.

A. It is a near-azeotrope, and must be liquid charged.

B. It must use polyol ester refrigerant oil, and that oil is very water absorbent. The system must not be open for more than 15 minutes.

C. An electronic leak detector capable of locating HFC-134a type refrigerant must be used to locate refrigerant leaks.

D. A special HFC type liquid line dryer must be used.

E. When evacuating, use of an electronic micron gage is recommended. Evacuate to 300 microns.

## **Liquid Charging**

Because R-404A is a near-azeotrope, only liquid refrigerant can be used to recharge the refrigeration system. To do that may take some special techniques:

### **Required tools**

Electronic scale

Refrigerant manifold

Two service valves

Sight glass or charge faster

1. Use an electronic scale to measure the charge.

2. Place a drum or cylinder of R-404A on the scale, valve side up (R-404A disposable cylinders have an internal dip tube and dispense liquid refrigerant from the valve when it is upright).

3. Attach the service valves to the low and hi charging hose of the refrigeration manifold and screw them to the ice machine access valves. Attach the charging hose to the cylinder of R-404A. Open the cylinder's valve and purge the hose to the manifold.

4. Close the low side service access valve.

5. Open the discharge side manifold valve and weigh in the name plate charge. After the charge is weighed in, wait a few minutes and re-check the scale.

6. If all of the refrigerant charge has not been weighed into the discharge side, it must be carefully added thru the low side. Close the discharge service access valve.

7. With a sight glass or charge faster in the hose to the low side port, start the ice machine.

8. Open the low side service access valve.

9. Crack open the low side manifold valve and watch the scale and sight glass. Open and close the low side manifold valve to flow liquid into the manifold but flash off to vapor before it enters the suction side of the refrigeration system. This should only be a few ounces at most.

10. After the scale equals the correct charge, shut off the valve on the refrigerant cylinder.

11. With the ice machine running and the discharge access valve closed, open both manifold valves to allow the refrigerant in the hoses to enter the system.

12. Shut the suction service access valve.

13. Remove the refrigeration manifold gages and service valves from the ice machine refrigerant system.

14. Replace and tighten all caps.

# WIRING DIAGRAM

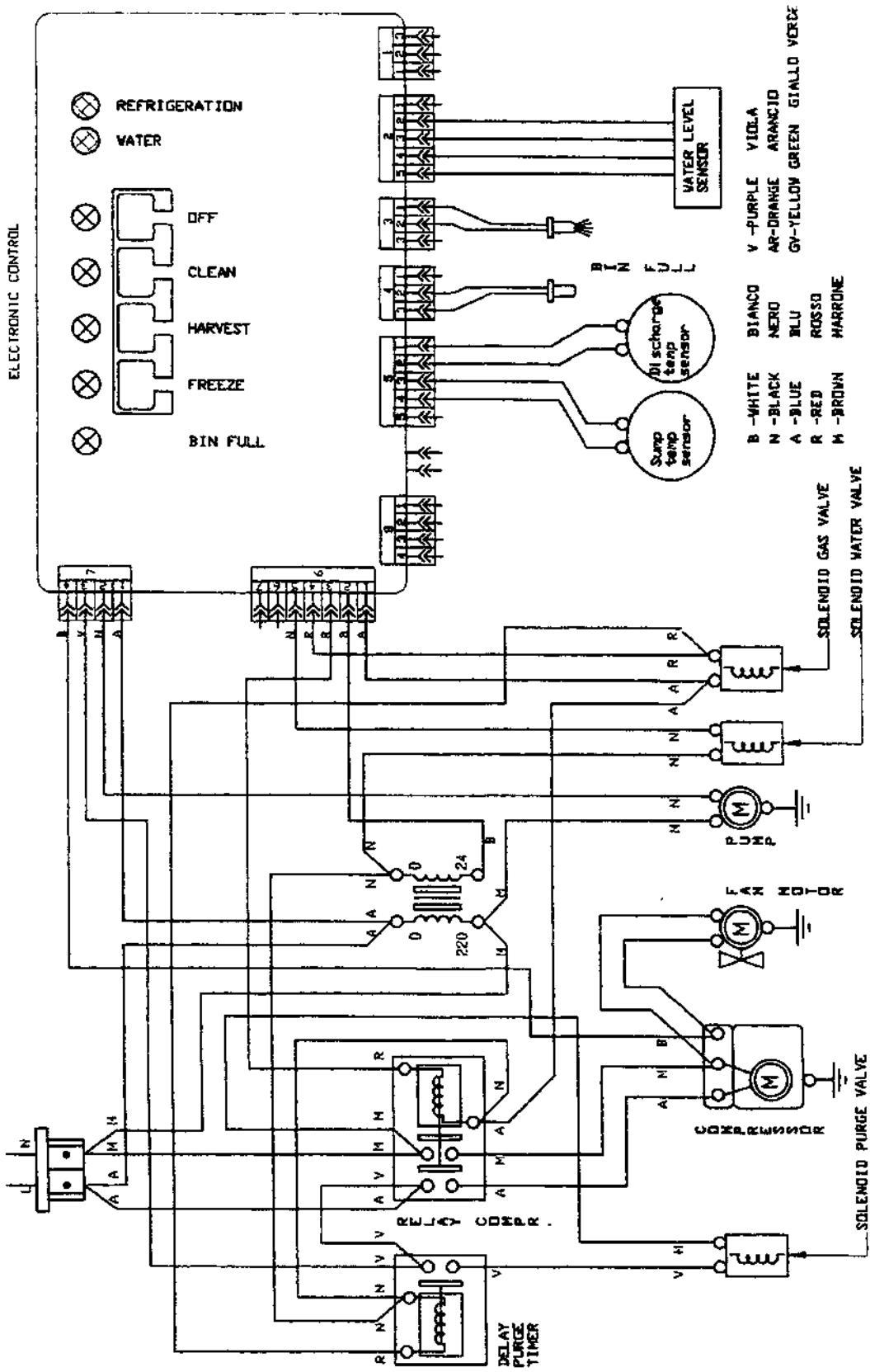

19262667/0