



SERIE 900

GAS AND COMBINATION RANGES

A.G.A. Approval No. **7163**

Models.

N9PC/G 400 – 800 – 120 – 160 orr ..4005 – 8005 – 1205 – 1605.

N9PCV/G 400 – 800 – 120 – 160 orr ..4005 – 8005 – 1205 – 1605.

N9PCF/G 800 – 120 – 160 orr ..8005 – 1205 – 1605 – 8023.

N9PCF/GE 800 – 120 – 160 orr ..8005 – 1205 – 1605 – 8023.

AUSTRALIAN DISTRIBUTOR :
SCOTS ICE AUSTRALIA PTY LTD
UNIT 8/13 BERRY STREET
CLYDE, N.S.W 2142

FREE CALL : 1800 222 460
EMAIL : scotsice@bigpond.com
WEB : www.scotsice.com.au

INSTRUCTION FOR INSTALLATION, ADJUSTEMENT, USE AND MAINTENANCE

BN41827730021AU9

CONTENTS

1- INSTRUCTIONS FOR INSTALLATION	page 3
1.1 Identifying the models	page 3
1.2 Technical data	page 3
2 - GENERAL INSTRUCTIONS	page 3
2.1 Installation	page 3
2.2 Assembling	page 3
2.3 Assembling the cook top on a neutral base	page 4
2.4 Aligning the equipment	page 4
2.5 Assembling the tops in bridge configuration	page 4
2.6 Connecting to the gas supply	page 4
2.7 Electrical connections (for ranges with electric ignition of burners) versions and electric oven burners)	page 4
2.8 Grounding and bonding of the equipment (for ranges with electric ignition of burners) versions and electric oven	page 4
3 - ADAPTING THE RANGE TO OTHER TYPES OF GAS	page 4
3.1 Replacing the pilot burner nozzles of the cook top	page 4
3.2 Replacing nozzles and air registers of the burners of the cook top	page 5
3.3 Replacing the minimum nozzle of the cook top	page 5
3.4 Replacing the pilot burner nozzles of the gas oven	page 5
3.5 Replacing nozzle and air registers of the burners of the gas oven	page 5
4 - STARTING	page 5
4.1 Checking the operation	page 5
4.2 Checking the thermal power	page 5
4.3 Checking the gas feeding pressure	page 5
5 - CHECK OF SOME MALFUNCTIONS	page 5
5.1 The pilot burner shows a difficult ignition or it fails to ignite	page 5
5.1.1.The pilot burner shows a difficult ignition or it fails to ignite (for ranges with electric ignition	page 5
5.2 Extinction of pilot burner during the operation	page 5
5.3 The main burners show a difficult ignition or they fail to ignite	page 5
5.4 Difficult control of oven temperature	page 5
5.5 Electric oven	page 5
5.5.1.The heating of the cooking compartment is not enabled.	page 5
5.5.2 Insufficient heating of the oven	page 5
5.5.3 Difficult control of the oven temperature	page 5
7- USE AND MAINTENANCE	page 5
7.1 Warning	page 6
7.2 Use of the cook top	page 6
7.3 Lighting the main burners of the cook top	page 6
7.3.1 Electric ignition of the burners of the cook top	page 6
7.4 Extinction of burners	page 6
7.5 Using the gas oven	page 6
7.6 Ignition of the burners of gas oven	page 6
7.7 Extinction of burners	page 6
7.8 Use of the electric oven	page 6
7.9 Switching off the oven in case of fault	page 7
8 - CLEANING AND MAINTENANCE	page 7
8.1 Cleaning the oven compartment	page 7
9 - LIST OF SPARE PARTS	page 7
10 - ENCLOSURES	page 8-15

1 - INSTRUCTIONS FOR INSTALLATION1.1 Identifying the models**SERIE 900**

	Models with manual ignition of fires		models with piezo igniter of burners	
Gas cook top-Top with 2 burners	41803161121AU BN418031611212AU	N9PC/G 400 N9PC/G4005		
Gas cook top-Top with 4 burners	41803161141AU BN418031611412AU	N9PC/G 800 N9PC/G8005		
Gas cook top-Top with 6 burners	41803161161AU BN418031611612AU	N9PC/G 120 N9PC/G1205		
Gas cook top-Top with 8 burners	41803161181AU BN418031611812AU	N9PC/G 160 N9PC/G1605		
2 burners with open base	41803121121AU BN418031211212AU	N9PCV/G 400 N9PCV/G4005		
4 burners with open base	41803121141AU BN418031211412AU	N9PCV/G 800 N9PCV/G8005		
6 burners with open base	41803121161AU BN418031211612AU	N9PCV/G 120 N9PCV/G1205		
8 burners with open base	41803121181AU BN418031211812AU	N9PCV/G 160 N9PCV/G1605		
4 burners with gas oven	41803141141AU BN418031411412AU	N9PCF/G 800 N9PCF/G8005	BN418031413412AAU	N9PCF/G8023
6 burners with gas oven	41803141161AU BN418031411612AU	N9PCF/G 120 N9PCF/G1205		
8 burners with gas oven	41803141181AU BN418031411812AU	N9PCF/G 160 N9PCF/G1605		
4 burners with electric oven	BN41803141149.AU BN418031411492AU	N9PCF/GE800 N9PCF/GE8005	BN418031413492AAU	N9PCF/GE8023
6 burners with electric oven	BN41803141169.AU BN418031411692AU	N9PCF/GE120 N9PCF/GE1205		
8 burners with electric oven	BN41803141189.AU BN418031411892AU	N9PCF/GE160 N9PCF/GE1605		

1.2 Technical data

The technical data of these appliances are indicated in the Tables T1 – T5 – T6

2 - GENERAL INSTRUCTIONS

Read the instructions of this handbook carefully because they supply important information on installation, use, maintenance safety. Keep this handbook for any further reference of the various operators. The installation, transformation and maintenance of this equipment must exclusively be carried out by authorised installers or by licensed gasfitters complying with the AS5601 (AG601) Gas Installation standards and any local authority requirements in force.

The Manufacturer declines any liability if these rules are not complied with.

N.B. - This equipment complies with the CEI standard 61-50 and AS4563.

2.1 Installation

- After unpacking, check that the equipment is intact. In case of any doubt, do not operate this unit and call immediately the appliance supplier.
- Arrange the packing elements far from children, because they can be dangerous.
- The equipment must definitively be installed in the position it occupies in the kitchen, preferably under an exhausting hood for a proper recirculation of air.

- The equipment must be installed only in rooms with good ventilation in accordance with the installation standards (AS5601).

- **Any commercial equipment of the type** must be installed only in rooms with a good exhaust system, according to the technical rules in force.

- Refer to the data plate on the appliance for relevant technical information e.g gas type, consumption, test point pressure, etc.

- These ranges can be installed separately, or assembled with other equipment of our product line.

- This range is not available in built-in version.

- The equipment must be positioned at least 10 cm far from any wall around it. Install the appliance in a non-combustable area. Ensure areas are suitably insulated if required in accordance with the installation standard (AS5601)..

- The overall dimensions of the equipment are indicated in the following pages.

2.2 Assembling

- Remove the protection film from the outer surfaces of the apparatus. Clean these surfaces from probable residual adhesive using a proper solvent.

- Adjust the height of the unit turning the adjustable feet.

- In stand-alone version, the range has a width of 40 cm and it must be fixed to the floor with the proper flanges (Fig. 2A).

2.3 Assembling the cook top on a neutral base (Fig. 3) ONLY FOR GAS MODELS

- Assemble the cook top on the proper neutral base through the following operations:
- Remove knobs, control board and back of the top.
- Position the top on its base.
- Fasten these two elements with the four screws V, as shown in the fig. 3.
- Reassemble the control board and the back of the top.

2.4 Aligning the equipment (Fig. 2)

Proceed as follows:

- Remove the knobs and the control board of the top.
- Arrange the apparatuses side by side and level at the same height.
- Fasten the apparatuses with the proper screws, as shown in the fig.2

2.5 Assembling the tops in bridge configuration (Fig. 3A)

- Fix the two supporting crossbars T in the proper holes drilled in the sides of the contiguous bases.
- Level the two bases carefully.
- Position the cook top on the crossbars and remove the knobs and the control board from this top.
- Fasten the top onto the crossbars with the four screws V, as shown in the fig. 3.
- Align and fix the equipments arranged side by side, as indicated above (paragraph 2.4 - Fig. 2).
- Reassemble the back, the control board and the knobs of the top.

2.6 Connecting to the gas supply Important!

- Clean the pipes to remove any dust, dirt or foreign material which could block the supply.
- Do not use pipes of a diameter smaller than that for which the appliance is designed. Ensure installation is "pipesized" for the whole installation.
- After installation the pipework, connections and appliance(s) should be checked for gas leaks in accordance with standard operations. Use soapy water to check connections for leaks.

Warning: Do not use naked flame to check for gas leaks!

- Make certain the appliance is arranged for the type of gas to be used. Otherwise the appliance will have to be converted to the applicable gas type. If not certain contact local gas supplier for confirmation of gas type. Any conversion to be carried out must be done by an authorised person in accordance with the supplied instructions.

- The use of flexible hoses: Where it is intended to connect the appliance to the gas supply using a flexible hose, it is important to use the correct type assembly for the application. Refer to AS5601 for hose connection requirements. The mounting of the hoses must comply with AS/NZS1869 – Class B and be kept as short as possible. A chain must be fitted to restrict the appliance movement to no more than 80% of the hose length.

- The section of the gas supply line must be sufficient to ensure the gas flow necessary for full operation of all of the appliances connected to the piping. Ensure an isolation valve and union is fitted at the inlet piping of the appliance.

- For **Natural gas and LPG** appliances, the regulator supplied with the appliance must be fitted between the gas valve and the appliance inlet.

- The constant outlet pressure will be guaranteed by the gas pressure regulator that regulates varying inlet pressures.
- When the regulator is fitted, it must be adjusted to the correct pressure when the burners are operating.

Test point pressures are: 1.0kPa for Natural Gas

2.65kPa for L.P.G. (Propane)

- Make sure the appliance is suitable for the type of gas available, verify it on the data plate.

- The supply pressure must be measured with the appliance operating, using a manometer (min 0.1kPa).

- Ensure gas is turned off.

- Remove control panel.

- Remove test point screw from the pressure test point and connect the manometer.

- Turn the gas on slowly, light the applicable burners and compare the value read on the manometer with that given on the data plate.

- If the manometer gives a pressure outside the range adjust the gas regulator supplying the appliance. If the pressure cannot be adjusted to the correct value check the installation to determine problem.

2.7 Electrical connections (for ranges with electric ignition of burners) versions and electric oven

The equipment has been designed to operate at the voltage indicated on the rating plate, with a tolerance of $\pm 10\%$.

Each unit must be powered through a separate line properly sized. The connection must be carried out on the terminal board where this line arrives, through a flexible cable sheathed with rubber H05RN-F and protected by a stiff plastic or metallic pipe. Special circuit breakers of proper capacity, with a contact opening of at least 3 mm, as well as other protection devices against direct and indirect contacts of uncovered parts and against fault currents to the ground, must be connected according to the standards in force (maximum allowable leakage current: 1 mA/kW).

View table T4 and T4a for characteristics and section of cable

2.8 Grounding and bonding of the equipment (for ranges with electric ignition of burners) versions and electric oven

Ground the equipment through the terminal marked with  on the terminal board where the line arrives.

Connect the metallic structure of any electric device to the terminal marked with bonding. 

3 - ADAPTING THE RANGE TO OTHER TYPES OF GAS

If the feeding gas is not among those prearranged, transform the equipment through the following operations.

Nozzles and rating plates are packed in a proper bag supplied with the equipment.

3.1 Replacing the pilot burner nozzles of the cook top (Fig.4) or (Fig.4 a)

- Remove knobs and control board.

a) Unscrew the union **R** or pos **5** and replace the nozzle **UP** with that indicated in the table **T1**.

b) Screw down the union **R** again.

3.2 Replacing nozzles and air registers of the burners of the cook top (Fig.5)

- Remove knobs and control board.
- Unscrew the nozzle **U** and replace it with that indicated in the table **T1**.
- Unscrew the screw **V** and set the air adjusting bush at the distance "**A**" indicated in the table **T1**.
- Screw down the screw **V** tightly and seal it with red paint.

3.3 Replacing the minimum nozzle of the cook top (Fig.1)

- Remove knobs and control board.
- Unscrew the minimum adjusting screw **VM** from the gas cock and replace with that indicated in the table **T1**.

3.4 Replacing the pilot burner nozzles of the gas oven (Fig. 4)

- Remove the lower horizontal panel.
- Unscrew the union **R** and replace the nozzle **UP** with that indicated in the table **T1**.

3.5 Replacing nozzles and air registers of the burners of the gas oven (Fig.5A)

- Remove the lower horizontal panel and the oven bottom.
- Unscrew the nozzle **U** and replace with that indicated in the table **T1**.
- Unloose the screws **V** and set the air register at the distance "**A**" indicated in the table **T1**.

4 - STARTING4.1 Checking the operation

Start the equipment according to the **instructions of use**, and check:

- the correct operation of pilot and main burners;
- that there are no leaks;
- the correct operation of room ventilation systems;
- the efficiency of the exhaust gas system; if necessary, refer to the paragraph 5 "**Check of some malfunctions**";
- whether the data of the rating plate of the equipment correspond to those of the mains or of the gas pipe network.

Warning: during the operation, take extreme care in handling the hot areas of the outer surface.

4.2 Checking the thermal power

After installing the equipment and adapting it to another gas group or in any maintenance operation, check the thermal power.

- The thermal power rating is indicated in the tables **T1 – T5 – and T6**.
- The equipment operates at the power rating when its nozzles where actually correspond to the type of gas supplied and to the operating pressure indicated in the table **T1**.
- As regards the control of feeding pressure, refer to the paragraph 4.3 "**Checking the gas feeding pressure**".

4.3 Checking the gas feeding pressure

- Necessary measuring instrument: pressure gage with minimum accuracy rating of 0.2 mBar.
- Remove the knobs and the control board of the cook top.

- Remove the tight screw of the pipe tap **P** (see fig. 1) and connect the pipe of the pressure gage to this tap.
- Carry out the measurement while the equipment is operating.
- The measured value must be included within the limits indicated in the table **T1**; otherwise, stop the test and call the gas service company.
- Disconnect the pipe of the pressure gage and screw down the screw of the test point tightly.

5 - CHECK OF SOME MALFUNCTIONS5.1 The pilot burner shows a difficult ignition or it fails to ignite

- Insufficient gas feeding pressure.
- Nozzle or pipe clogged.
- The gas cock or the gas valve of the oven are faulty.
 - The piezoelectric lighter or the pilot burner cable of the oven are broken.

5.1.1 The pilot burner shows a difficult ignition or it fails to ignite (for ranges with electric ignition)

- The ignition plug is faulty, dirty, or wrongly installed.
- The ignition pushbutton is faulty.
- The ignition transformer is faulty.
- Defect in the electric wiring.
- There is no power supply.

5.2 Extinction of pilot burner during the operation

- The thermocouple is faulty, or it is not properly heated, or not correctly connected to the gas cock or to the gas valve of the oven.
- Gas feeding pressure drop.
- The gas cock is faulty.
- The gas valve of the oven is faulty.

Screw down the screws

5.3 The main burners show a difficult ignition or they fail to ignite

- Insufficient gas feeding pressure.
- Nozzles clogged.
- The gas cock is faulty.
- The gas valve is faulty.

5.4 Difficult control of oven temperature

The gas valve is faulty.

5.5 Electric oven5.5.1 The heating of the cooking compartment is not enabled.

Possible causes:

- the oven is not powered
- the safety thermostat is enabled (the green LED is on and the yellow LED is off)
- the control thermostat is faulty.

5.5.2 Insufficient heating of the oven.

Possible causes:

- one or more resistors are faulty
- the switch is faulty
- a phase of the power supply is missing.

5.5.3 Difficult control of the oven temperature.

Possible causes:

- the control thermostat is faulty

7 - USE AND MAINTENANCE

7.1 Warning

This equipment has been designed for professional aims, therefore it must be operated exclusively by trained personnel. It must exclusively be used to cook food in pots and pans; consequently any other use is improper.

Its installation and possible transformation for other gas group must be carried out by authorized and qualified installers.



In case of troubles, turn off the gas cock and disconnect the main power switch, that are installed before the equipment.

For any repair, call the authorized After-Sales Service and require only original spare parts.

Not complying with these instructions may seriously compromise the safety of this equipment; the manufacturer declines any liability in case these warnings are not complied with.

7.2 Use of the cook top

The knob controlling the cocks of the cook top is marked with the following symbols:

- off
- ★ pilot burner on
-  maximum fire
-  minimum fire

7.3 Lighting the main burners of the cook top

The pilot burners of the open fires must be lit manually (for example with a match).

- Press and turn the knob to the position ★ .
- Press the knob completely and light the pilot burner approaching a match flame. After lighting, keep the knob pressed for approximately 20 seconds, then release it. In case of extinction of the pilot burner, repeat this operation.
- Turn the knob to the desired position chosen between



7.3.1 Electric ignition of the burners of the cook top

- Press and turn the knob to the position ★ .
- Press the knob completely; at the same time press the ignition pushbutton.
- The discharges between plug and pilot burner will provoke the automatic ignition of the pilot burner.
- Release the ignition pushbutton and keep the knob pressed for approximately 20 seconds, then release it. In case of extinction of the pilot burner, repeat this operation.
- Turn the knob to the desired position chosen between

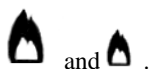

7.4 Extinction of burners

- Switch off the main burner turning the knob to the position ★ .
- Switch off the pilot burner pressing and turning the knob to the position ● .

7.5 Using the gas oven

The control knob of the gas valve is marked with the following references:

- Off
- ★ Pilot burner
- 100 MINIMUM cooking temperature
- 200 AVERAGE cooking temperature
- 320 MAXIMUM cooking temperature

7.6 Ignition of the burners of gas oven

- Press and turn the knob to the position ★ .
- Press the knob completely and light the pilot burner pressing the pushbutton of piezoelectric lighter. After lighting, keep the knob pressed for approximately 20 seconds, then release it. In case of extinction of the pilot burner, repeat this operation.
- The pilot flame can be seen (opening the oven doors) through the peep hole on hotplate of oven
- Turn the knob to the position corresponding to the desired temperature.
- Do not keep the door open while the oven is operating.

7.7 Extinction of burners

- Put off the burner turning the knob to the position ★ .
- Put off the pilot burner pressing and turning the knob to the position ● .

7.8 Use of the electric oven (Fig. 3)

Safety devices

The oven is equipped with a safety three-pole thermostat of manual reset. When the cooking compartment is overheated, this element is enabled and disconnects the power supply from the oven resistors. The yellow LED is off, while the green one is on. In this case, disconnect the equipment turning the knobs **MT** and **ME** to **0**, cut off the power supply turning off the main switch, installed before the range, and call the after-sales service.

This oven is equipped with 2 control knobs and 2 LEDs - warning lights (Fig. 1):

- Knob of the main switch / thermostat **MT**, for controlling the cooking temperature
- Knob of the switch **ME**, for controlling the working of the top resistors of the cooking compartment or both.
- Green warning light (LED) indicating "current on"
- Yellow warning light (LED) indicating "heating on"

The knob of the thermostat **MT** is marked with the following symbols:

0	Power supply off
50	Minimum temperature
100 - 200	Intermediate temperature values
300	Maximum temperature

The knob of the switch **ME** is marked with the following symbols:

0	Disconnected resistors
1	Top resistors
2	Bottom resistor
3	Top resistors + bottom

Connecting the heating of the electric oven:

1. PRE-HEATING

- Turn the knob of switch **ME** (Fig. 7) to **3**; then turn the knob **MT** to the position corresponding to the desired temperature: the green and yellow LEDs are on. The top and bottom resistors are powered at the maximum value until the desired temperature is reached: this is signalled by the yellow warning light that gets off.

2. COOKING AT DIFFERENT TEMPERATURES

- Turn the knob of switch **ME** to the properest position, 1 – 2 or 3.
- Turn the knob of the thermostat to the position corresponding to the desired temperature: the green (current on) and yellow (resistors powered) warning lights are on.
As the desired temperature is reached, the yellow warning light gets off.

- **Never keep the door open when the oven is operating.**

DISCONNECTING THE HEATING OF THE OVEN

- Disconnect the power supply from the oven turning the knob of the thermostat **MT** to **0**: the green and yellow LEDs are off.
- Turn the knob **ME** too, to **0**.

7.9 Switching off the oven in case of fault

- In case of any fault, stop the equipment operation turning all the knobs **MC**, **MT** and **ME** (Fig. 7) to **0**.
- Turn off the main power switch, installed before the equi
Call an authorized After-Sales Service Centre

8 - CLEANING AND MAINTENANCE

- Wash the surfaces of stainless steel with water and non abrasive detergents, every day; then rinse abundantly and wipe.
- When cleaning stainless steel, never use detergents with abrasive substances, chips, steel wool, brushes or scrapers of common steel.
- Clean the floor under the range with non corrosive products.
- Clean the burners every day and the slots of fire caps to remove possible scales.
- Do not wash the equipment with water jets.

When the equipment must not be used for long time, Proceed as follows:

- Turn off the gas cock and disconnect the main switch of the power supply, that are installed before the equipment.
- Clean all the surfaces carefully.
- Protect the surfaces of stainless steel laying off a light film of white mineral oil with a cloth.
- Ventilate the rooms periodically.
- Check the equipment periodically (at least once a year); this check must be carried out by qualified professional personnel.
- Drawing up a maintenance contract is recommended.

8.1 Cleaning the oven compartment

Clean the oven compartment every day. For this, use only suitable products and comply with the supplier's instructions. Here is the procedure suggested:

- These operations must be carried out with the oven at a temperature below 70 °C
- Open the oven door and spray a proper product onto the surfaces to be cleaned.
- Shut the door for the time required for the cleaning action (10-15 min).

- Open the door with caution because there may be some vapors, and remove the oven bottom and shelves to wash them separately.
- Clean the inside of the oven compartment and rinse with a sponge soaked with lukewarm water.
- Reassemble the components removed, and heat the oven for some minutes to dry its cooking compartment.

It is recommended the appliance be visually checked for problems each week and the appliance be serviced by an authorised service person at least every 12 months or as may be required. This is not covered by warranty.

9 - LIST OF SPARE PARTS

- Gas cock of the cook top
- Pilot burner
- Open fire burners
- Thermocouples
- Knobs of gas cocks
- Gas valve of the oven
- Ignition plug of gas oven pilot burner
- Piezoelectric lighter of gas oven
Pilot burner cable of gas oven.

List of spare parts for ranges with electric ignition of burners

- Ignition pushbutton
- Ignition transformer
High voltage cables
- Ignition plug
-

Electric oven

- Main four-pole switch
- Operating three-pole thermostat
- Safety three-pole thermostat
- Switch
- Oven resistors of 1500 W - 230 V
- Green and yellow warning lights (LEDs)
- Thermostat knob
- Knob of the switch.

T1 Serie 900

Models.				
N9PC/G 400 – 800 – 120 – 160 N9PCV/G 400 – 800 – 120 – 160 N9PCF/G 800 – 120 – 160				
N9PCF/GE 800 – 120 – 160				
Gas	p kPa		❶ Open Burners	Oven
			7 kW - 27 MJ/h Nat Gas 25 MJ/h L.P.G	8,5 kW - 33MJ/h Nat Gas - 29MJ/h L.P.G
			Ø 128 mm	
Nat Gas	1.00	Pilot burner nozzle ❷	32	32
		Burner nozzle ❸	235	265
		Minimum adjusting screw ❹	75 adjustable	---
		A= mm ❺	23	24
L.P.G	2.65	Pilot burner nozzle ❷	19	19
		Burner nozzle ❸	135	145
(Prop)		Minimum adjusting screw ❹	75	---
		A= mm ❺	45	26

Models.				
N9PC/G 4005 – 8005 – 1205 – 1605. N9PCV/G 4005 – 8005 – 1205 – 1605. N9PCF/G 8005 – 1205 – 1605 – 8023.				
N9PCF/GE 8005 – 1205 – 1605 – 8023				
Gas	p kPa		❶ Open Burners	Oven
			7 kW - 27 MJ/h Nat Gas 25 MJ/h L.P.G	8,5 kW - 33MJ/h Nat Gas - 29MJ/h L.P.G
			Ø 128 mm	
Nat Gas	1.00	Pilot burner nozzle ❷	32.2	32
		Burner nozzle ❸	235	265
		Minimum adjusting screw ❹	80 adjustable	---
		A= mm ❺	23	24
L.P.G	2.65	Pilot burner nozzle ❷	16.2	19
		Burner nozzle ❸	130	145
(Prop)		Minimum adjusting screw ❹	75	---
		A= mm ❺	41	26

- ❶ Fuochi aperti - Offene Kochstellen - Open burners - Feux vifs - Open vlammen
- ❷ Ugello pilota - Zündbrennerdüse - Pilot burner nozzle - Injecteur de la veilleuse - Gaspitten pilot
- ❸ Ugello bruciatore - Brennerdüse - Burner nozzle - Injecteur du brûleur - Gaspitten brander
- ❹ Vite minimo - Kleinsteinstschraube - Minimum adjusting screw - Vis de réglage minimum - Schroef minimum stand
- ❺ A= Regolazione aria primaria - Primärluftabstand - Primary air adjustment - Regulation de l'air - Regeling aanfangslucht

T5 Serie 900

Models	Open Burners		Oven	Variants	Version	
41803161121AU BN418031611212AU	N9PC/G 400 N9PC/G4005	n° 2 x 7 kW			Top	
41803161141AU BN418031611412AU	N9PC/G 800 N9PC/G8005	n° 4 x 7 kW				
41803161161AU BN418031611612AU	N9PC/G 120 N9PC/G1205	n° 6 x 7 kW				
41803161181AU BN418031611812AU	N9PC/G 160 N9PC/G1605	n° 8 x 7 kW				
41803121121AU BN418031211212AU	N9PCV/G 400 N9PCV/G4005	n° 2 x 7 kW			Open base	
41803121141AU BN418031211412AU	N9PCV/G 800 N9PCV/G8005	n° 4 x 7 kW				
41803121161AU BN418031211612AU	N9PCV/G 120 N9PCV/G1205	n° 6 x 7 kW				
41803121181AU BN418031211812AU	N9PCV/G 160 N9PCV/G1605	n° 8 x 7 kW				
41803141141AU BN418031411412AU	N9PCF/G 800 N9PCF/G8005	n° 4 x 7 kW	n° 1 x 8,5 kW		Gas oven	
41803141161AU BN418031411612AU	N9PCF/G 120 N9PCF/G1205	n° 6 x 7 kW	n° 1 x 8,5 kW			
41803141181AU BN418031411812AU	N9PCF/G 160 N9PCF/G1605	n° 8 x 7 kW	n° 2 x 8,5 kW			
41803141341.AAU BN418031413412AAU	N9PCF/G812 N9PCF/G8023	n° 4 x 7 kW	n° 1 x 8,5 kW	Piezo igniter of burners		
41803141149.AU BN418031411492AU	N9PCF/GE800 N9PCF/GE8005	n° 4 x 7 kW	/		Electric oven	
41803141169.AU BN418031411692AU	N9PCF/GE120 N9PCF/GE1205	n° 6 x 7 kW	/			
41803141189.AU BN418031411892AU	N9PCF/GE160 N9PCF/GE1605	n° 8 x 7 kW	/			
41803141349.AAU BN418031413492AAU	N9PCF/GE812 N9PCF/GE8023	n° 4 x 7 kW	/	Piezo igniter of burners		
Q MJ/h	NAT GAS		min 8,1 MJ/h	max 27 MJ/h	33 MJ/h	
	L.P.G		min 8,1 MJ/h	max 25 MJ/h	29 MJ/h	
GAS 1kPa m ³ /h Gas consumption **	NAT			0,74	0,90	
2,65 kPa kg/h	L.P.G			0,54	0,66	
Connection gas* ISO 7/1 R 3/4 #						

T6 Serie 900

Models	Qn Mj/h		Gas consumption **			Type
	NAT GAS	L.P.G	NAT GAS		LPG	
			m ³ /h		kg/h	
41803161121AU BN418031611212AU	54	50	1,48		1,09	A1
41803161141AU BN418031611412AU	108	100	2,96		2,18	
41803161161AU BN418031611612AU	162	150	4,44		3,26	
41803161181AU BN418031611812AU	216	200	5,93		4,35	
41803121121AU BN418031211212AU	54	50	1,48		1,09	A1
41803121141AU BN418031211412AU	108	100	2,96		2,18	
41803121161AU BN418031211612AU	162	150	4,44		3,26	
41803121181AU BN418031211812AU	216	200	5,93		4,35	
41803141141AU BN418031411412AU	141	129	3,86		2,84	A1
41803141161AU BN418031411612AU	195	179	5,34		3,92	
41803141181AU BN418031411812AU	282	258	7,72		5,67	
BN418031413412AAU	141	129	3,86		2,84	
41803141149.AU BN418031411492AU	54	50	1,48		1,09	A1
41803141169.AU BN418031411692AU	108	100	2,96		2,18	
41803141189.AU BN418031411892AU	162	150	4,44		3,26	
BN418031413492AAU	54	50	1,48		1,09	

** Consumo gas - Gasverbrauch - Gas consumption - Consommation du gaz - Gasverbruik

* Connessione gas - Gasanschluss - Arrivée gaz - Verbindung gas

If the unit installed in Denmark the nipple is to be screwed to the supply ramp.

Before connecting the unit to the gas supply plant you are required to screw the nipple given together with the supply ramp.

T4 Serie 900

Modelli - Models - Modèles Modelle - Modellen	Alimentazione elettrica - Power supply - Speisung Alimentation électrique - Elektrische voeding		
	V	W	Cavo - Cable - Kabel H07RN - F mm ²
N9PCF/G8023 cod. BN418031413412AAU	240V~ 1N - 50 Hz	5	n° 3 x 1 mm ²

T4a Serie 900

Modelli - Models - Modèles Modelle - Modellen	Forno elettrico - Electric oven Four électrique - Elektro-Backofen Elektrische oven kW	V	A	Cavo - Cable Kabel H07RN - F mm ²
N9PCF/GE800 cod. 41803141149.AU N9PCF/GE8005 cod. BN418031411492AU N9PCF/GE8023 cod. BN418031413412AAU	6	400V~ 3N	13	n° 5 x 1,5 mm ²
N9PCF/GE120 cod. 41803141169.AU N9PCF/GE1205 cod. BN418031411692AU	6	400V~ 3N	13	n° 5 x 1,5 mm ²
N9PCF/GE160 cod. 41803141189.AU N9PCF/GE1605 cod. BN418031411892AU	12 (n°2 x 6 kW)	400V~ 3N	26	n° 5 x 2,5 mm ²

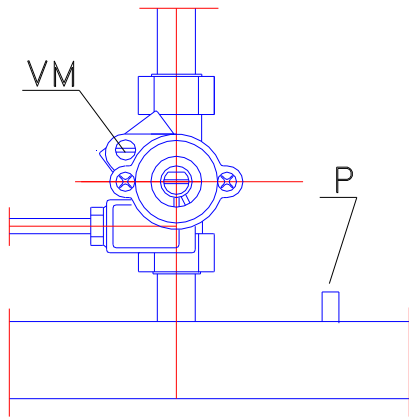

Fig.1 - Abb. 1

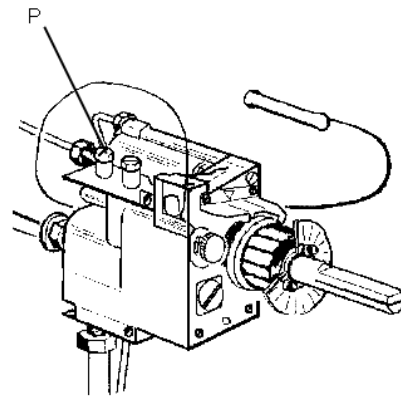

Fig.1/A- Abb. 1/A

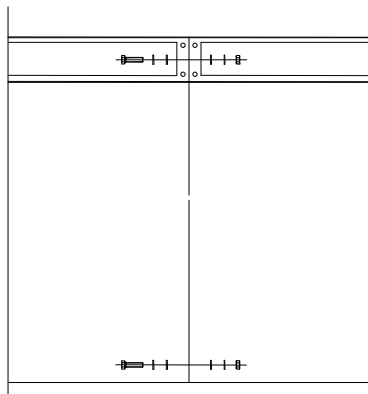

Fig. 2 - Abb. 2

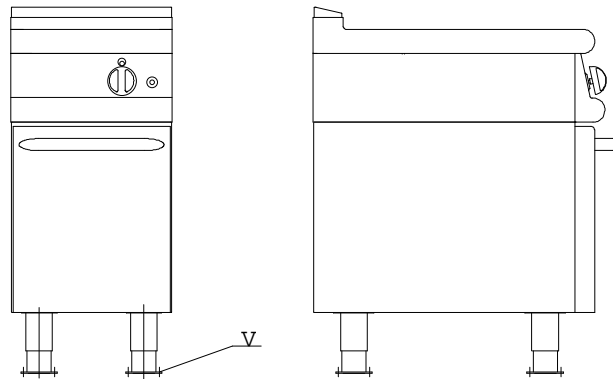

Fig. 2/A - Abb. 2/A

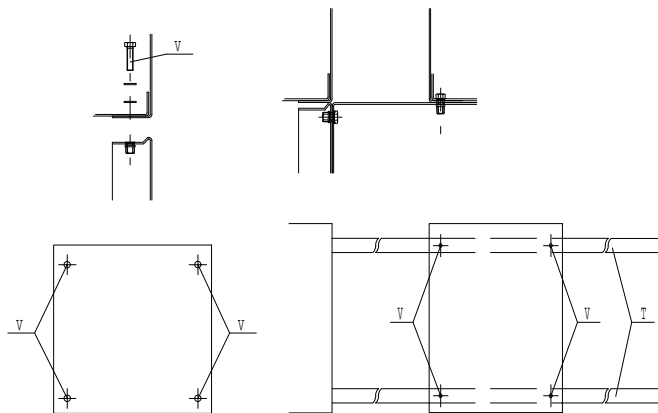

Fig. 3 - Abb. 3

Fig. 3/A - Abb. 3/A

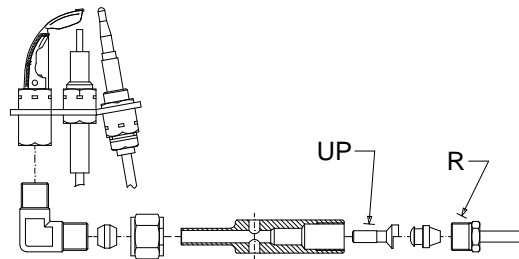

Fig. 4 - Abb. 4 Valid for models
N9PC/G 400 - 800 -120 -160.
N9PCV/G 400 - 800 -120 -160.
N9PCF/G 800 -120 -160.
N9PCF/GE 800 800 -120 -160.

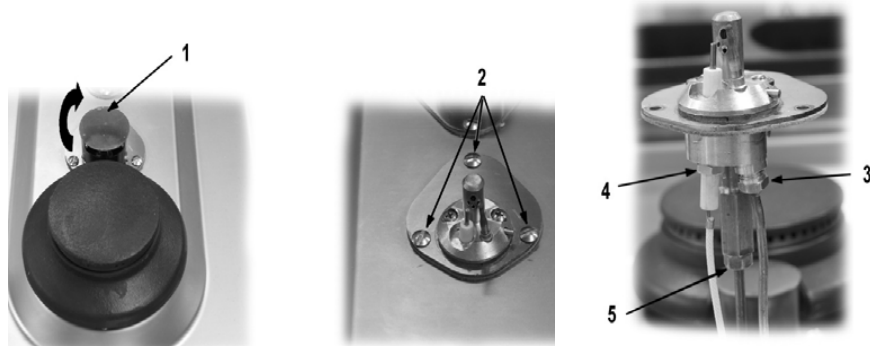

Fig. 4 a - Abb. 4 Valid for models
 N9PC/G 4005 - 8005 -1205 -1605.
 N9PCV/G 4005 - 8005 -1205 -1605.
 N9PCF/G 8005 - 8023 -1205 -1605.
 N9PCF/GE 8005 - 8023 -1205 -1605 .

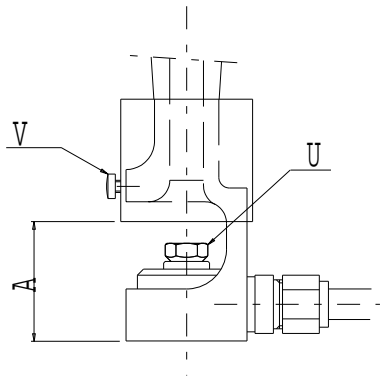

Fig.5 - Abb.5

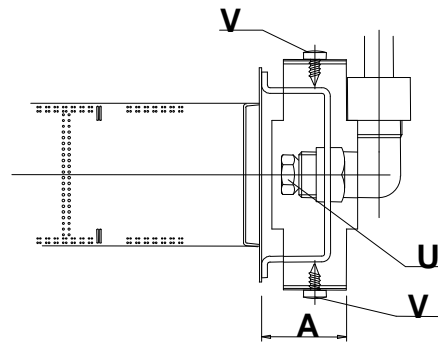

Fig.5/A - Abb. 5/A

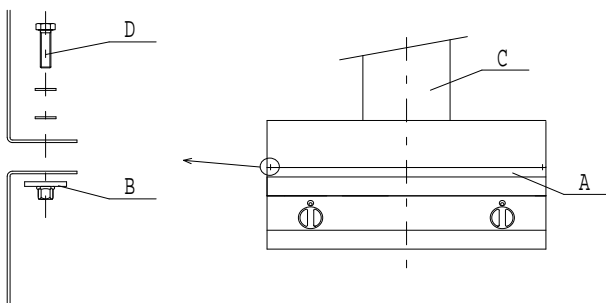

Fig.6 - Abb. 6

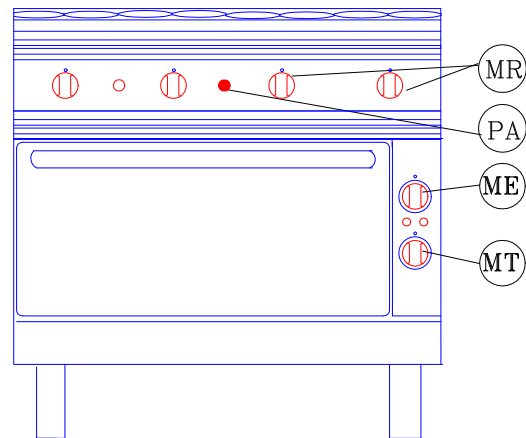
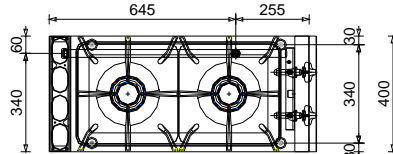
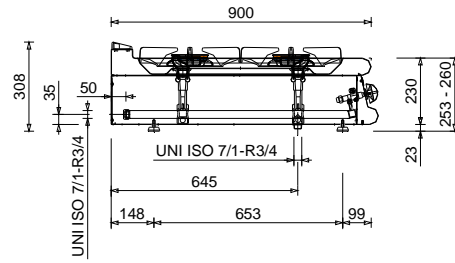
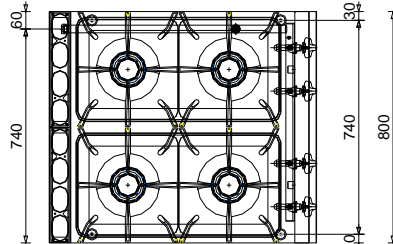

Fig.7 - Abb.5



Mod. N9PC/G400 - N9PC/G4005
 Cod.41803161121.AU
418031611212AU



Mod. N9PC/G800 - N9PC/G8005
 Cod.41803161141.AU
418031611412AU

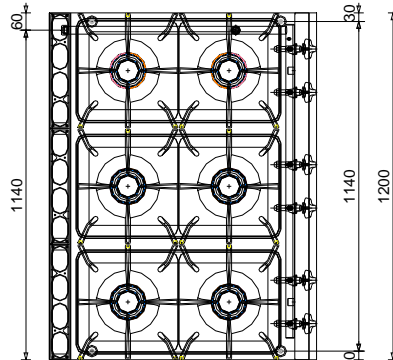

Mod. N9PC/G120 - N9PC/G1205
 Cod.41803161161.AU
418031611612AU

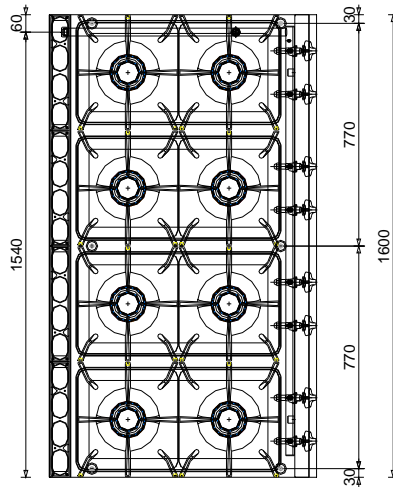

Mod. N9PC/G160 - N9PC/G1605
 Cod.41803161181.AU
418031611812AU

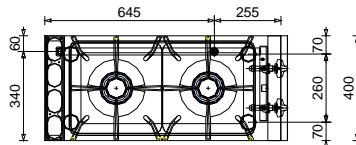
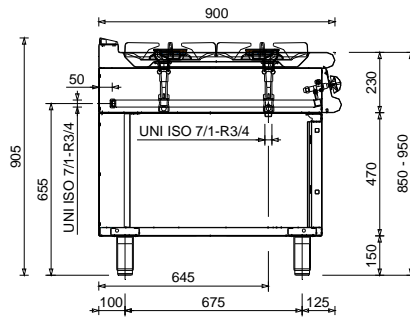

Mod. N9PCV/G400 - N9PCV/G4005
 Cod.41803121121.AU
418031211212AU

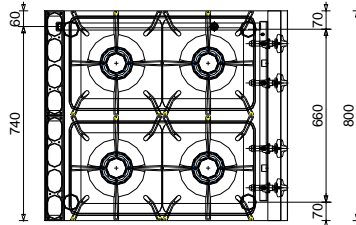

Mod. N9PCV/G800 - N9PCV/G8005
 Cod.41803121141.AU
418031211412AU

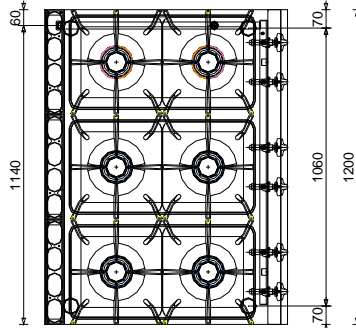

Mod. N9PCV/G120 - N9PCV/G1205
 Cod.41803121161.AU
418031211612AU

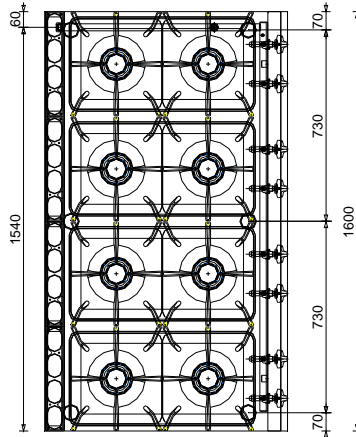

Mod. N9PCV/G160 - N9PCV/G1605
 Cod.41803121181.AU
418031211812AU

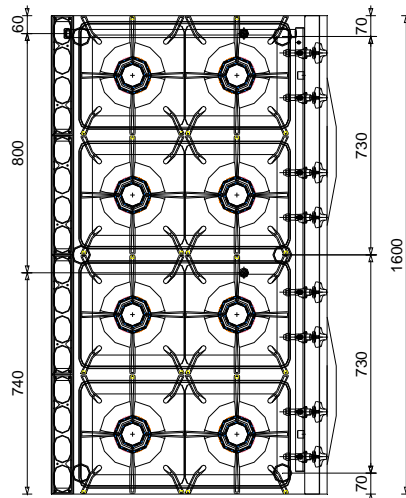
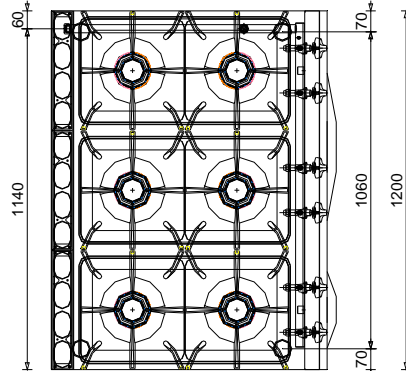
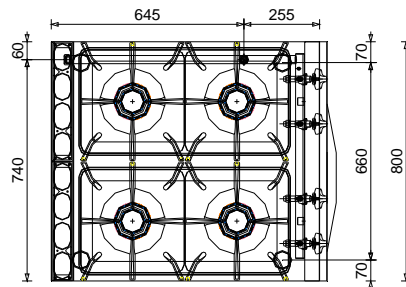
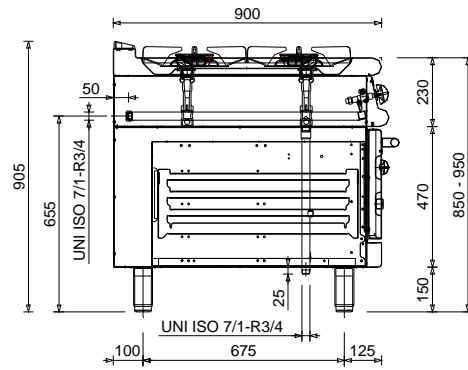

Mod. N9PCF/G800 - N9PCF/G8005 -
 N9PCF/GE800 - N9PCF/GE8005 -
 N9PCF/G8023 - N9PCF/GE8023
 Cod.41803141141.AU
418031411412AU
41803141149.AU
418031411492AU
418031413412AAU
418031413492AAU

Mod. N9PCF/G120 - N9PCF/G1205 -
 N9PCF/GE120 - N9PCF/GE1205
 Cod.41803141161.AU
418031411612AU
41803141169.AU
418031411692AU

Mod. N9PCF/G160 - N9PCF/G1605 -
 N9PCF/GE160 - N9PCF/GE1605
 Cod.41803141181.AU
418031411812AU
41803141189.AU
418031411892AU