

ELECTRIC TILTING BRATT PANS

Series 900

TYPE: 9BR/E100, 9BR/E105, 9BRS/E100, 9BRS/E105

Service manual



Dear Customer,

Congratulations on deciding to choose a Baron appliance for your kitchen activities. You made an excellent choice. We will do our best to make you a satisfied Baron customer like thousands of customers we have around the world.

Please read this manual carefully. You will learn correct, safe and efficient working methods in order to get the best possible benefit from the appliance. The instructions and hints in this manual will give you a quick and easy start, and you will soon note how nice it is to use the Baron equipment.

All rights are reserved for technical changes.

You will find the main technical data on the rating plate fixed to the equipment. When you need service or technical help, please let us know the serial number shown on the rating plate. This will make it easier to provide you with correct service.

For your convenience, space is provided below for you to record your local Baron service contact information.

Baron TEAM

Baron service phone number:.....

Contact person:.....

1. General	1
1.1 Symbols used in the manual	1
1.2 Symbols used on the appliance	2
1.3 Checking the relationship of the appliance and the manual	2
2. Safety	3
2.1 Using the appliance safely	3
2.2 Safety instructions in case of malfunction	3
2.3 Disposing of the appliance	3
3. Functional description	5
3.1 Application of the appliance	5
3.1.1 Prohibited use	5
3.2 Construction	5
3.3 Operating principle	5
3.3.1 Operating switches and indicator lights	6
4. Operating instructions	7
4.1 Before using the appliance	7
4.1.1 Preparing the appliance for use	7
4.2 4.2 - Using the appliance	7
4.2.1 Filling the tank	7
4.2.2 Switching on the appliance	7
4.2.3 Adjusting the power	8
4.2.4 Cooking liquid and semi-liquid foods	9
4.2.5 Cooking solid foods	9
4.2.6 Switching off the appliance	9
4.2.7 Emptying the tank	9
4.3 After-use care	11
4.3.1 Cleaning	11
4.3.2 Idle period	12
4.3.3 Periodic maintenance	12
5. Installation	13
5.1 General information	13
5.1.1 Regulatory installation conditions	13
5.2 Possible environmental interference	13
5.3 Storage	13
5.4 Unpacking the appliance	14

5.5 Disposing of packing materials	14
5.6 Positioning	14
5.7 Electrical connections	14
5.7.1 General information	14
5.7.2 Connecting a type "Y" power lead to the appliance's terminal block	15
5.7.3 Morsetto equipotenziale	15
5.8 Allacciamento idrico	16
5.9 Staff training	16
5.10 Rating plate	17
6. Maintenance	19
6.1 Removing the right angle	19
6.2 Removing the left angle	19
6.3 Removing the front panel	20
6.4 Removing the rear side	20
6.5 Removing the right side	20
6.6 Removing the left side	20
6.7 Removing the top	20
6.8 Replacing the heating elements	22
6.9 Replacing the operating thermostat	24
6.10 Replacing the switch	26
6.11 Replacing the safety thermostat	27
6.12 Resetting the safety thermostat	27
6.13 Replacing the power regulator	28
6.14 Replacing the contactor	28
6.15 Replacing the micro switch	30
6.16 Adjusting the micro switches	30
6.17 Replacing the water filling valve	31
6.18 Replacing the cover spring	32
6.19 Replacing the lifting device of the spring	34
6.20 Replacing the trapezoidal female screw	35
6.21 Periodic greasing of the mechanical parts for tank movements	36
7. Troubleshooting	37
8. Spare parts	39
8.1 Voltage codes	41
8.2 Product codes	41

9. Technical specifications 51

1. General

Carefully read the instructions in this manual as they contain important information regarding proper, efficient and safe installation, use and maintenance of the appliance.

Keep this manual in a safe place for eventual use by other operators of the appliance.

The installation of this appliance must be carried out in accordance with the manufacturer's instructions and following local regulations. The connection of the appliance to the electric and water supply must be carried out by qualified persons only.

Persons using this appliance should be specifically trained in its operation.

Switch off the appliance in the case of failure or malfunction. The periodical function checks requested in the manual must be carried out according to the instructions. Have the appliance serviced by a technically qualified person authorized by the manufacturer and using original spare parts.

Not complying with the above may put the safety of the appliance in danger.

1.1 Symbols used in the manual



This symbol informs about a situation where a safety risk might be at hand. Given instructions are mandatory in order to prevent injury.



This symbol informs about the right way to perform in order to prevent bad results, appliance damage or hazardous situations.



This symbol informs about recommendations and hints that help to get the best performance out of the appliance.



This symbol informs about a function that has to be taken into account in self-control.

1.2 Symbols used on the appliance



This symbol on a part informs about electrical terminals behind the part. The removal of the part must be carried out by qualified persons only.

1.3 Checking the relationship of the appliance and the manual

The rating plate of the appliance indicates the serial number of the appliance. If the manuals are missing, it is possible to order new ones from the manufacturer or the local representative. When ordering new manuals it is essential to quote the serial number shown on the rating plate.

2. Safety

2.1 Using the appliance safely

Being an appliance designed only for professional use, it should be operated by qualified personnel exclusively. Never leave the appliance unattended while it is on.

Do not move the appliance while hot.

2.2 Safety instructions in case of malfunction

In the event of a failure, abnormal operation etc., disconnect the appliance from power supply. Call the service.

2.3 Disposing of the appliance

This appliance has been manufactured using recyclable raw materials and does not contain any hazardous or toxic substances. When disposing of the appliance and all its packing materials, ensure strict compliance with all applicable regulations in force in the installation location. Packing materials should be separated by type and subsequently delivered to specific collection sites. Ensure compliance with environmental protection regulations.

3. Functional description

3.1 Application of the appliance

The appliance is designed for use in the gastronomy and confectionery industries only.

The bratt pan is intended for cooking and frying raw materials and also for cooking sauces.

3.1.1 Prohibited use

This appliance should not be used as if it were a fryer.

The manufacturer cannot be held liable for any faults caused by defective installation or inappropriate use of the appliance. In such cases, the warranty shall be null and void.

3.2 Construction

Stainless steel bearing structure resting on four height-adjustable feet. Outer covering and worktop are all stainless steel.

Pan is nodular cast iron, a material that exhibits a high thermal conductivity, thus ensuring a faster thermal response and preventing food from sticking to the bottom..

3.3 Operating principle

Heating is obtained by means of sheathed heating elements installed outside the pan and capable of withstanding mechanical and thermal stress.

The temperature of the pan may be set to any value between 50°C (122°F) and 300°C (572°F).

3.3.1 Operating switches and indicator lights



Fig. 1

1. Water supplier
2. Water filling valve
3. Line pilot lamp
4. Operation indicator light
5. Temperature adjustment knob
6. Power regulator knob
7. Pan cover handle
8. Lifting handle

4. Operating instructions

4.1 Before using the appliance

4.1.1 Preparing the appliance for use

Prior to cooking for the first time, we recommend that you clean the appliance, and especially the cooking pan, very thoroughly. Remove all packing materials and adhesive films from the appliance very carefully. Before cleaning the stainless steel parts, make sure that the detergent you intend to use does not contain any abrasive substances and that it is suitable for stainless steel surfaces. Wipe the appliance dry with a clean cloth.

Never use water jets to clean the appliance.

4.2 4.2 - Using the appliance

4.2.1 Filling the tank

Fill the tank with water to the maximum level by opening the filling valve.

The tank of the appliance must not be filled to more than maximum level, internally marked.

4.2.2 Switching on the appliance

Turn the knob (item 2 in Fig. 2) in a clockwise direction and the pilot lamp comes on (item 1 in Fig. 2). The line pilot lamp remains on until the knob is turned back to 0 position again (item 2 in Fig. 2). If you turn the knob further, the operation indicator light turns on (item 3 in Fig. 2). When the set temperature is reached it goes off.

You can select the temperature of the bottom of the tank between 50°C (item 4 in Fig. 2) and 300°C (item 5 in Fig. 2).

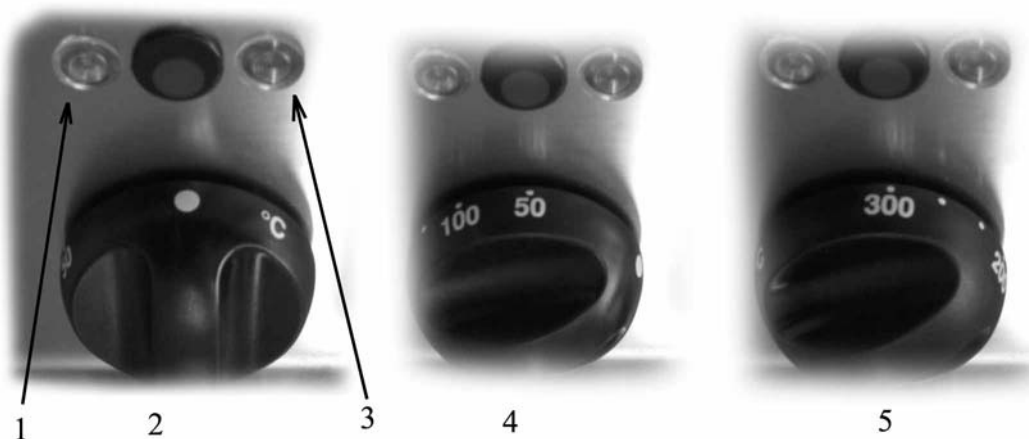

Fig. 2

1. Line pilot lamp
2. OFF position
3. Operation indicator light
4. Minimum position
5. Maximum position

4.2.3 Adjusting the power

If you turn the knob in item 1 in Fig. 3, the bottom of the tank starts heating with variable pulses that increase proportionally to your needs (the bottom of the tank is constantly heated in item 4 in Fig. 3).;

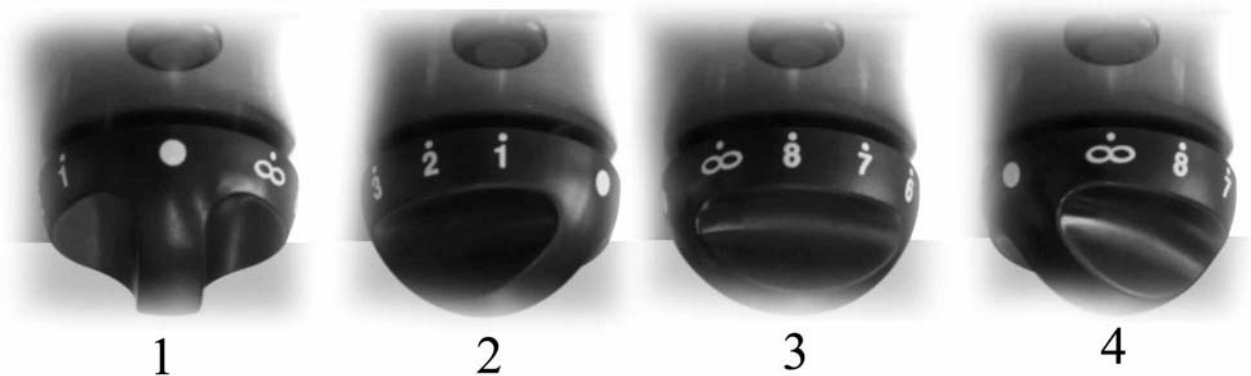

Fig. 3

1. OFF position
2. Minimum position
3. Maximum position
4. Continuous position

4.2.4 Cooking liquid and semi-liquid foods

- Select the cooking temperature using adjustment knob.
- Check the tank is always filled with water.

Never leave the appliance unattended while in use.

4.2.5 Cooking solid foods

- Select the cooking temperature using temperature adjustment knob.
- Apply some oil or fat on the bottom of the tank.
- When the set temperature has been reached, put the food to be cooked in the tank.
- When the bottom side of the food has reached the desired cooking grade, invert it and cook the other side.
- When both sides are cooked, decrease the temperature and leave the food into the tank until its using.

Never leave the appliance unattended while in use.

4.2.6 Switching off the appliance

Switch the appliance off by turning the knob up to item 2 in Fig. 2. The line lamp will now turn off.

4.2.7 Emptying the tank



Give utmost attention to this operation, which must be carried out when the liquid into the tank has cooled down.

The appliance is equipped with automatic system that stops the electrical heating if the tank is lifted during the operation.

- Switch the appliance off as shown in the previous paragraph.
- Turn the handle (item 1 in Fig. 4) in a clockwise direction.
- The tank starts lifting up to the desired position or to the end stop position.
- In order to horizontally place the tank again, turn it in a counter-clockwise direction.

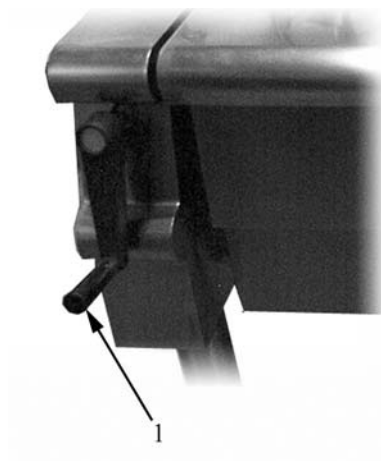

Fig. 4

1. Handle for lifting tank

4.3 After-use care

4.3.1 Cleaning

Before cleaning, turn off the appliance and shut off power supply upstream of it.

Wait until the appliance has cooled down before you start cleaning it.

General information

The main causes for stainless steel wear or corrosion are:

- using abrasive or acid detergents, especially chlorine-based products such as hydrochloric acid or sodium hypochlorite (bleach). Therefore, before buying a detergent product, make sure it does not corrode stainless steel (see also paragraph "Routine cleaning");
- stagnation of ferrous deposits (such as those created by rust dissolved in the water flowing through the piping, especially after the appliance has remained idle for some time). Therefore, avoid such stagnation. Do not use wire scourers to remove the most stubborn food residues. Use, rather, scourers or spatulas made of stainless steel or softer, non-ferrous materials;
- stagnation of substances having acid components such as vinegar, lemon juice, sauces, salt, etc. Avoid prolonged contact of the stainless steel parts of the appliance with those substances. The evaporation of saline solutions over the surfaces of the appliance is particularly harmful to them.

Routine cleaning

Cleaning the appliance thoroughly on a daily basis is the key to keeping it in perfect working condition and prolonging its life. Clean the appliance with a damp cloth using water and soap or detergents, provided that they are not acid or abrasive as discussed further above. Such detergents should not even be used to wash the floor near the appliance, as their fumes may deposit on the steel surfaces and damage them. If the appliance is very dirty, use a synthetic Scotch Brite™ type sponge. Rinse it off with clean water and wipe it dry with a clean cloth. Do not rub the appliance with wire scourers as they could leave rust stains. For the same reason, avoid touching the appliance with ferrous objects.

Never use direct water jets to clean the appliance because this could result in water entering into it and damaging it.

Stains and abrasions on the steel surface

Scratches and dark stains may be smoothed or removed using stainless steel scourers or synthetic abrasive sponges, which should always be rubbed in the same direction as the satin finish.

Rust

If you need to remove rust stains, contact manufacturers of industrial detergents to find a suitable product. Industrial descaling products can also be used to that end. After using

Operating instructions

the descaler and rinsing off the appliance with clean water, an alkaline detergent may be required to neutralize any acid compounds left on the surface.

4.3.2 Idle period

If the appliance will remain idle for a certain period of time, clean it and wipe it dry first, and then apply a film of a suitable product (such as vaseline oil spray or similar products) to protect it.

Turn off power supply upstream of the appliance.

4.3.3 Periodic maintenance

Only qualified personnel are allowed to carry out service and maintenance operations.

The following maintenance operations should be performed at least once a year:

- lubricating all pan tilting mechanisms
- checking for proper operation of all control and safety devices

We recommend that you sign a service agreement providing for at least one check-up a year.

5. Installation

5.1 General information



The manufacturer cannot be held liable for any injuries to persons or damage to property resulting from installation errors or from inappropriate use of the appliance and is not responsible for any faults caused by defective installation. In such cases, the warranty shall be null and void.



Installation, maintenance, connection to power supply, and start-up should all be performed by an authorised installer who must ensure compliance with all applicable safety regulations in force in the location where the appliance is being installed.



Check that the appliance is pre-set to operate on the voltage available at the place of use. Should the available voltage rating be different, do not install the appliance.

5.1.1 Regulatory installation conditions

We remind you that all appliances installed in public assembly buildings must meet the requirements specified below. Ensure that installation and maintenance of the appliance are performed in strict compliance with all applicable regulations and standards in force, namely:

- safety regulations on fire hazard and panic in public assembly buildings;
- general regulations applicable to all appliances;
- heating, ventilation, refrigeration, air conditioning, and generation of steam and hot water for sanitary use;
- installation of foodservice cooking appliances;
- specific regulations applicable to each type of public assembly building (hospitals, shops, etc.).

5.2 Possible environmental interference



If the appliance is installed in the immediate vicinity of other electric appliances, make sure that they do not interfere with each other. They should all have independent power supplies.

5.3 Storage

If the appliance is stored in a warehouse where room temperature is below 0°C (32°F), it should be warmed up to at least +10°C (50°F) before switching it on.

5.4 Unpacking the appliance

Prior to installation, remove all packing materials from the appliance. Some parts are wrapped in adhesive film, which should be thoroughly removed (see paragraph "Before using the appliance").

5.5 Disposing of packing materials

Packing materials should be disposed of in compliance with all applicable regulations in force at the installation location. Packing materials should be separated by type and subsequently delivered to specific collection sites. Ensure compliance with environmental protection regulations.

5.6 Positioning



Always close the water shut-off valve and disconnect power to the appliance before attempting to repair or service it.

Level the appliance using a bubble level. The appliance's height can be adjusted by means of its adjustable feet. In this way, the appliance will be firmly secured.

Ensure compliance with all workplace fire and safety regulations.

5.7 Electrical connections

5.7.1 General information



The appliance must always be connected to an earthing (grounding) system while in operation.

The appliance is pre-set to be connected to the electrical switchboard. Before connecting the appliance to the power supply network check:

- that distribution network voltage matches the voltage shown on the appliance's rating plate;
- that the grounding (earthing) system is effective;
- that the power cord is made of rubber and is of at least the same quality as cable type H07RN-F, with wires having a cross section suited to the maximum load they will carry (refer to "*Technical specifications table*" at the end of this manual);
- that an effective multi-pole breaker having a contact gap of at least 3 mm was fitted upstream of the appliance at the time of installation. Automatic thermal-magnetic circuit breakers may be used for this purpose. The multi-pole breaker should be installed in the immediate vicinity of the appliance and be readily accessible. We recommend fitting a thermal-magnetic circuit breaker with built-in fuse protection;
- that the power cord of the appliance is not exposed to direct heat sources.

5.7.2 Connecting a type "Y" power lead to the appliance's terminal block

INFO The power lead can only be replaced by the manufacturer, by the manufacturer's technical support service or by a technician having similar qualifications (the appliance is supplied complete with power lead).

To access the power supply terminal block, proceed as follows:

- disconnect power;
- remove the right angle and the right side as indicated in the related paragraphs;

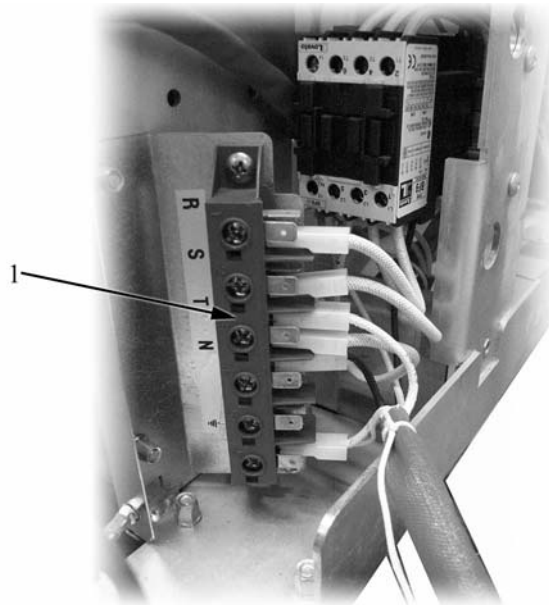

Fig. 5

1. Terminal block

- after removing the front panel, you can directly access the power supply terminal block of the appliance (pos. 1 in Fig. 5).

The power lead should be locked in place with the cable clamp fitted on the appliance so as to avoid the risk of tearing it.

The length of the ground (earth) cable should be such as to allow it to support any possible mechanical stress **after** the live leads.

5.7.3 Morsetto equipotenziale

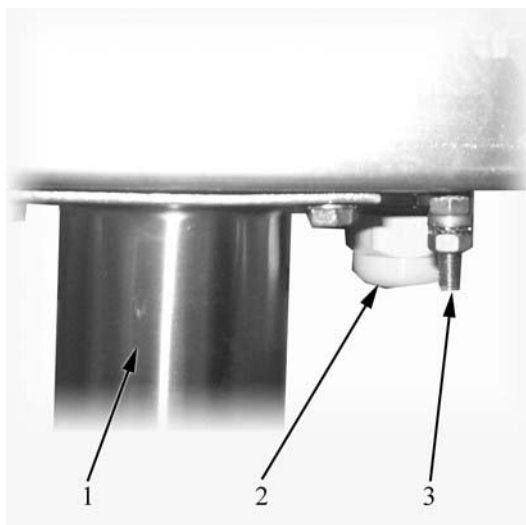

L'apparecchiatura deve essere collegata in un sistema equipotenziale. A tale scopo sulla parte inferiore destra dell'apparecchiatura, nei pressi dei vari allacciamenti, si trova il morsetto di collegamento contrassegnato dalla dicitura "equipotential" (in Fig. 6).

**Fig. 6**

1. Piedino posteriore destro
2. Pressacavo
3. Morsetto equipotenziale

5.8 Allacciamento idrico

Il raccordo per l'alimentazione d'acqua deve essere in metallo di tipo rigido o flessibile, con tubature di sezione proporzionata.

5.9 Staff training

Inform all personnel in charge of operating the appliance about how to use it by referring to this user's manual and hand them out the manual.

5.10 Rating plate

The rating plate showing the specifications of the corresponding model is applied in the position shown in the installation and connection drawings and includes the data listed below:

Manufacturer:	
Model:	(see front page)
Serial number:	
Year of manufacture:	
Category:	(see "Technical specifications table")
Heating power:	(see "Technical specifications table")
Natural gas consumption:	(see "Technical specifications table")
Liquid gas consumption:	(see "Technical specifications table")
Supply pressure:	
natural gases: G20	(see "Table of gas categories and pressure values" further above)
liquid gases (butane/propane): G30/G31	(see "Table of gas categories and pressure values" further above)
town gas: G110/G120	(see "Table of gas categories and pressure values" further above)
Gas inlet pipe size:	(see "Technical specifications table")
Supply voltage:	(see the label on the packing and on the appliance)
Appliance pre-set to use:	

6. Maintenance

Always disconnect the appliance from the power supply before attempting to repair it or service it.

6.1 Removing the right angle

- unscrew the fixing screws item 5 in Fig. 7;
- take off the right angle.

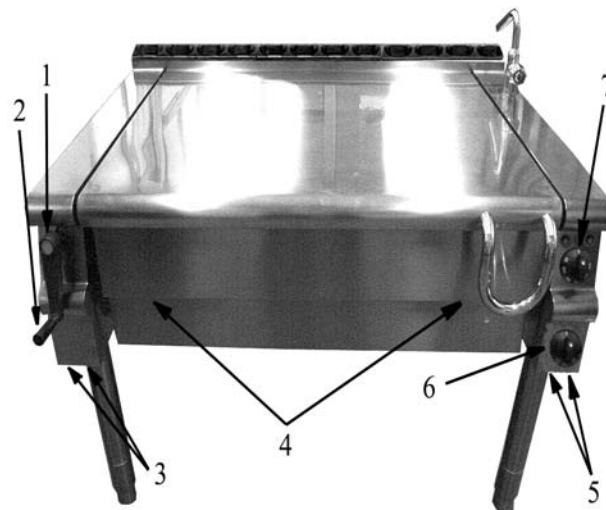

Fig. 7

1. Handle fixing plug
2. Handle
3. Left angle iron fixing screws
4. Front panel fixing screws
5. Right angle iron fixing screws
6. Power regulator knob
7. Temperature control range

6.2 Removing the left angle

- take out the fixing plug of the handle item 1 in Fig. 7;
- take off the handle item 2 in Fig. 7 from rod;
- unscrew the fixing screws item 3 in Fig. 7;
- take off the left angle.

6.3 Removing the front panel

- unscrew the fixing screws item 4 in Fig. 7;
- take off the front panel.

6.4 Removing the rear side

- unscrew the 4 back fixing screws;
- take off the rear side.

6.5 Removing the right side

- remove the right angle as indicated in the related paragraph;
- unscrew the 2 fixing screws on the rear side, the 2 screws on the side, and the 2 bottom fixing screws on the frame;
- take off the right side.

6.6 Removing the left side

- remove the left angle as indicated in the related paragraph;
- unscrew the 2 fixing screws on the rear side, the 2 screws on the side, and the 2 bottom fixing screws on the frame;
- take off the left side.

6.7 Removing the top

- remove the rear side, the angles and the sides as indicated in the related paragraphs (according to indicated order);
- unscrew the front fixing screws item 1 and item 2 in Fig. 8;



Fig. 8

1. Front fixing screws of the left top
2. Front fixing screws of the right top

- unscrew the back fixing screws item 1 in Fig. 9;

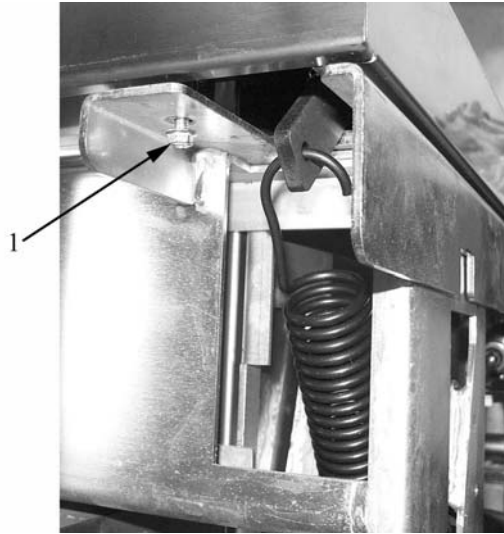

Fig. 9

1. Fixing screws of the back top
- remove the grids of the hood;
 - unscrew the fixing nut of the water column extension item 2 in Fig. 10;

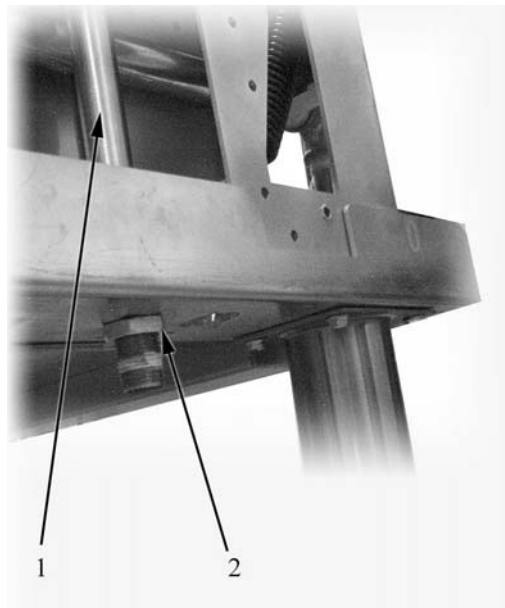

Fig. 10

1. Water column extension
 2. Fixing nut of the water column extension
- lift the top.

6.8 Replacing the heating elements

- unscrew the fixing screws (item 1 and item 2 in Fig. 11) of the connection cover (item 3 in Fig. 11);



Fig. 11

1. Front fixing screws of the connection cover (2)
2. Lateral fixing screws of the connection cover (6)
3. Connection cover

- disconnect all of the heating element electrical connections (item 3 in Fig. 12);
- remove the central protection (item 4 in Fig. 12);
- move the insulation plate and unscrew the fixing nuts of the faulty heating element (item 5 in Fig. 12);

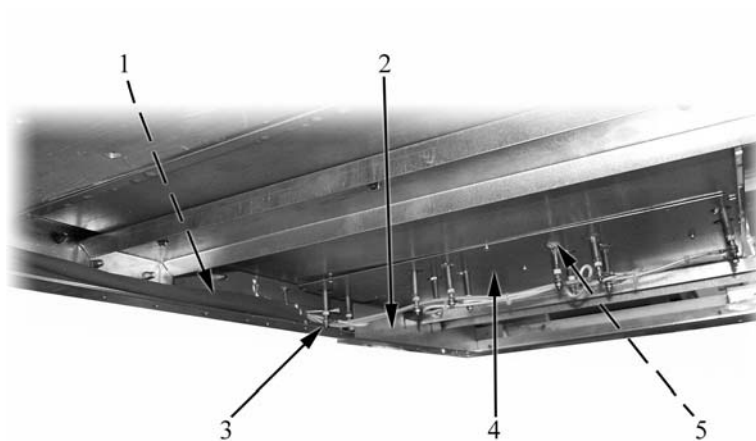

Fig. 12

1. Right lateral protection
2. Left lateral protection
3. Electrical connections
4. Central protection
5. Fixing nut of the heating element

- Lift the tank up to maximum height;
- unscrew the fixing screws of the faulty heating element squares (item 2 in Fig. 13);

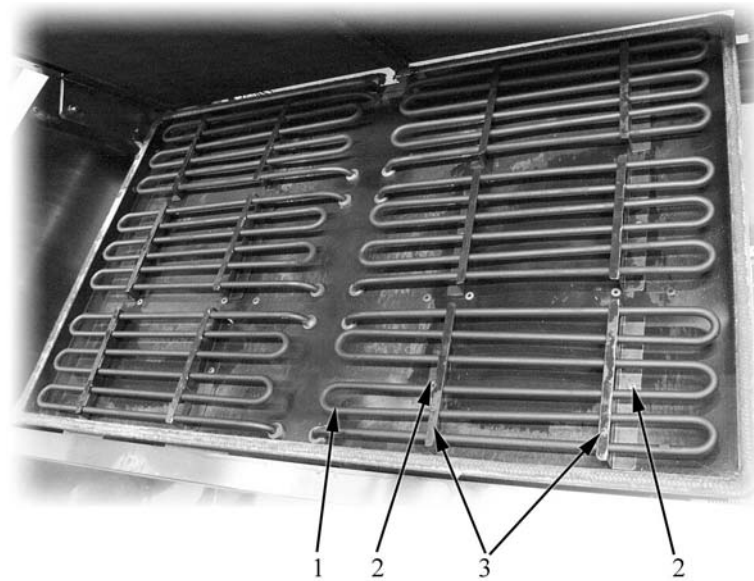

Fig. 13

1. Heating element
2. Square fixing screws
3. Fixing squares of the heating elements

- take off the heating element/square assembly and use latter (item 3 in Fig. 13);
- take off the squares from the faulty heating element and insert them on the new part;
- replace it and follow the procedure in reverse to fix the new one in place.

6.9 Replacing the operating thermostat

- remove the right angle, the right side, and the front panel as indicated in the related paragraphs;
- loosen the fixing screws (item 5 in Fig. 14) of the plates locking capillary tubes (item 6 in Fig. 14);
- slide the bulb (item 1 in Fig. 14) from the holder by taking out the spring clip (item 2 in Fig. 14);

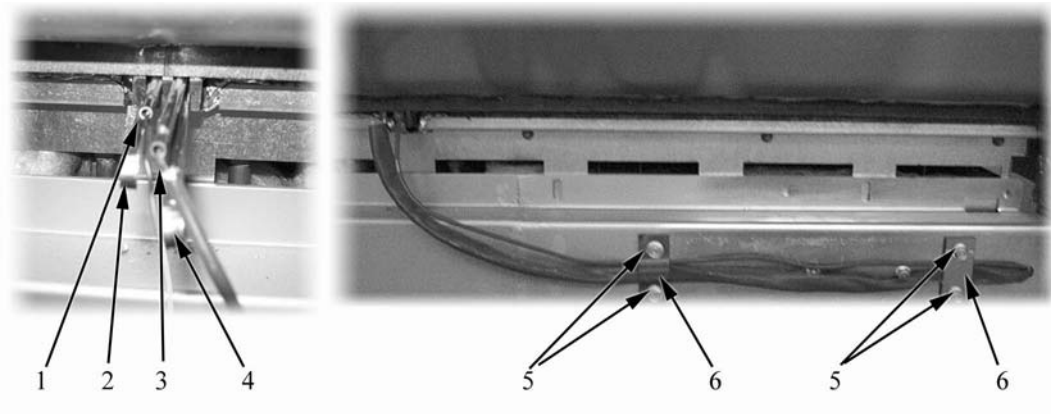
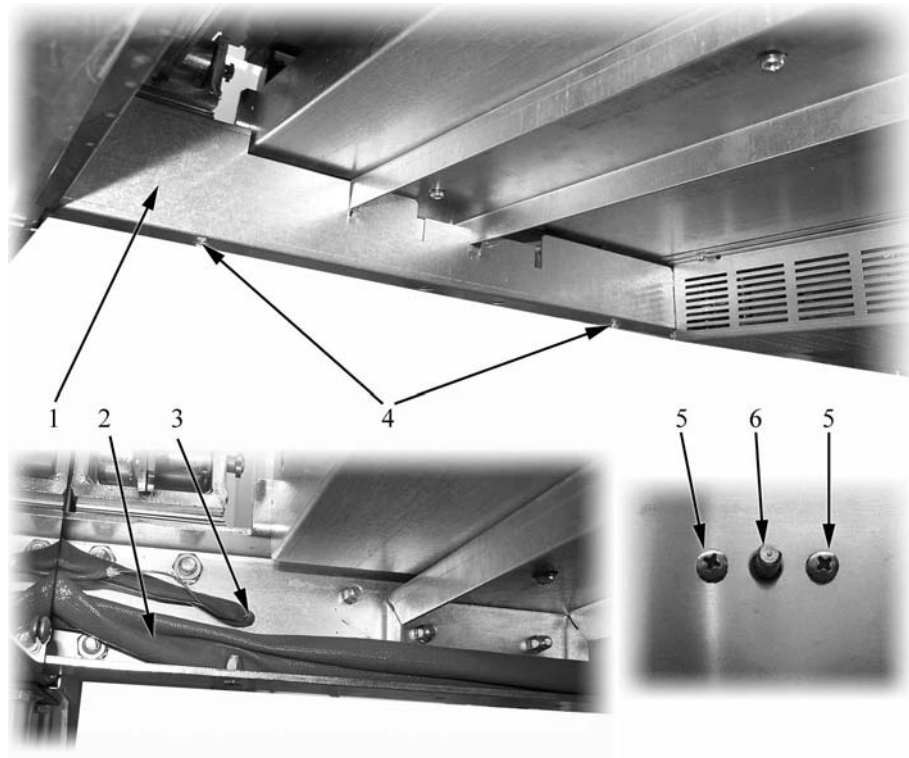

Fig. 14

1. Operating thermostat bulb
 2. Spring clip of the operating thermostat bulb
 3. Safety thermostat bulb
 4. Spring clip of the safety thermostat bulb
 5. Plate fixing screws
 6. Plates locking capillary tubes
- unscrew the fixing screws of the cover (item 4 in Fig. 15), remove the latter (item 1 in Fig. 15) and take the bulb out completely through the access hole of the thermostat capillary tubes (item 3 in Fig. 15);

**Fig. 15**

1. Cover
2. Heating element cables
3. Access hole of bulb capillary tubes
4. Cover fixing screws
5. Thermostat/switch unit fixing screws
6. Thermostat/switch unit

- remove the knob (item 7 in Fig. 7);
- unscrew the front fixing screws of the thermostat/switch unit (item 5 in Fig. 15) and remove it;
- disconnect the electrical connections (item 5 in Fig. 16);
- with the aid of screwdriver straighten the coupling bracket tongues of thermostat-switch (item 3 in Fig. 16) to detach the two components;

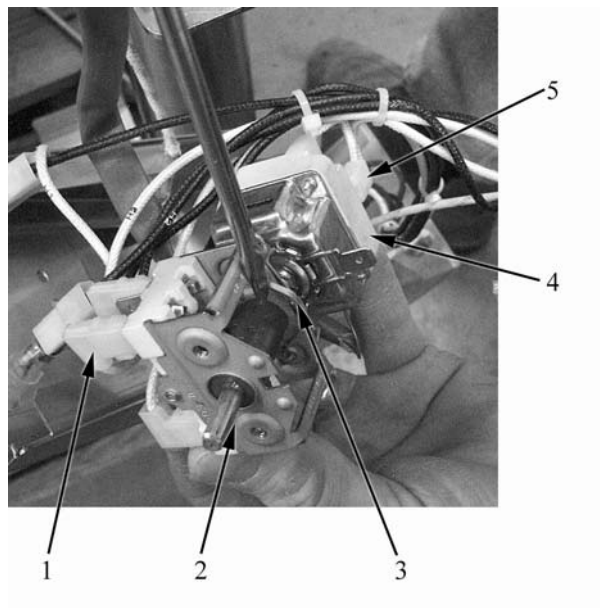

Fig. 16

1. Switch electrical connections
2. Switch
3. Coupling bracket
4. Operating thermostat
5. Operating thermostat electrical connections

- follow the procedure reverse for fixing the new part in place, by using the coupling bracket is just removed, taking care to place the bulb in its housing.

6.10 Replacing the switch

- remove the right angle as indicated in the related paragraph;
- remove the knob (item 7 in Fig. 7) ;
- unscrew the front fixing screws of the thermostat/switch unit (item 5 in Fig. 15) and remove it;
- disconnect the electrical connections (item 1 in Fig. 16);
- with the aid of screwdriver straighten the coupling bracket tongues of thermostat-switch (item 3 in Fig. 16) to detach the two components;
- follow the procedure in reverse to fix the new part by using the coupling bracket again.

6.11 Replacing the safety thermostat

- remove the right angle, the right side, and the front panel as indicated in the related paragraphs;
- loosen the fixing screws (item 5 in Fig. 14) of the plates locking capillary tubes (item 6 in Fig. 14);
- slide the bulb (item 3 in Fig. 14) from the holder by taking out the spring clip (item 4 in Fig. 14);
- unscrew the fixing screws of the cover (item 4 in Fig. 15), remove the latter (item 1 in Fig. 15) and take the bulb out completely through the access hole of the thermostat capillary tubes (item 3 in Fig. 15);
- unscrew the fixing screws of the thermostat (item 1 in Fig. 17) and remove it (item 2 in Fig. 17);

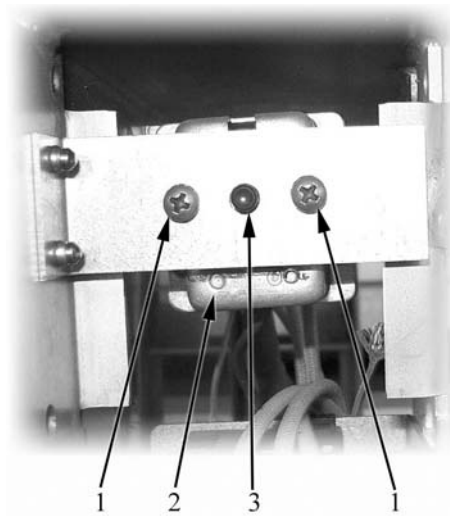

Fig. 17

1. Thermostat fixing screws
2. Safety thermostat
3. Reset button

- unweld the soldered wires;
- connect the new safety thermostat by tinning the wires unwelded previously;
- follow the procedure reverse for fixing the new part in place, taking care to place the bulb in its housing.

6.12 Resetting the safety thermostat

To reset the safety thermostat, proceed as follows:

- Remove the right angle as indicated in the related paragraph;
- press the reset button (item 3 in Fig. 17) until you hear a metal click;
- follow the procedure in reverse to fix the removed parts.

6.13 Replacing the power regulator

- remove the right angle as indicated in the related paragraph;
- remove the knob (item 6 in Fig. 7) ;
- disconnect the electrical connections (item 1 in Fig. 18);
- unscrew the front fixing screws of the power regulator and remove it (item 2 in Fig. 18);

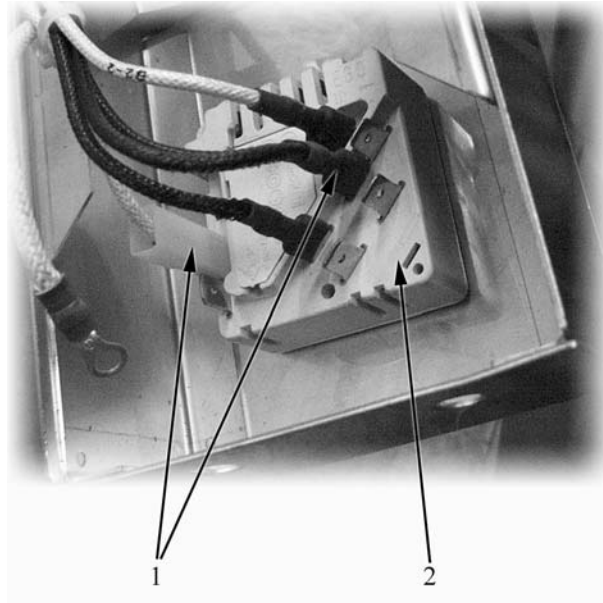

Fig. 18

1. Power regulator electrical connections
2. Power regulator

- follow the procedure in reverse to fix the new part.

6.14 Replacing the contactor

- remove the right angle and the right side as indicated in the related paragraphs;
- disconnect the electrical connections (item 1 in Fig. 19);
- remove the contactor (item 2 in Fig. 19);

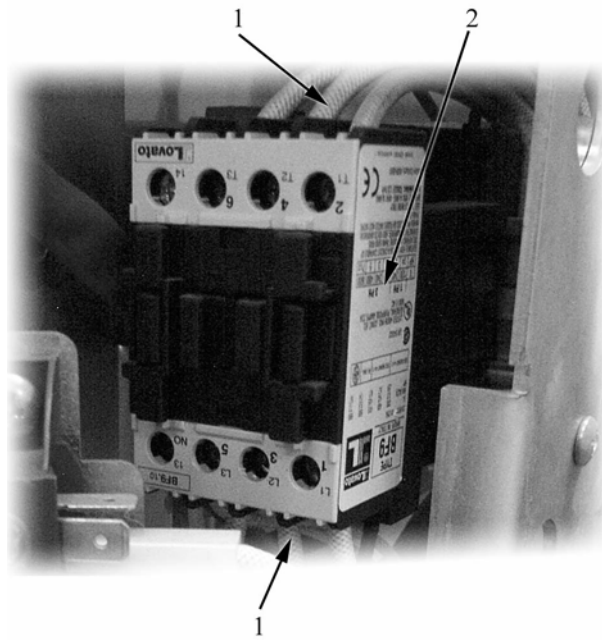

Fig. 19

1. Contactor electrical connections
2. Contactor

- follow the procedure in reverse to fix the new part.

6.15 Replacing the micro switch

- remove the left angle and the left side as indicated in the related paragraphs;
- disconnect the electrical connections of the micro switch (item 2 in Fig. 20);

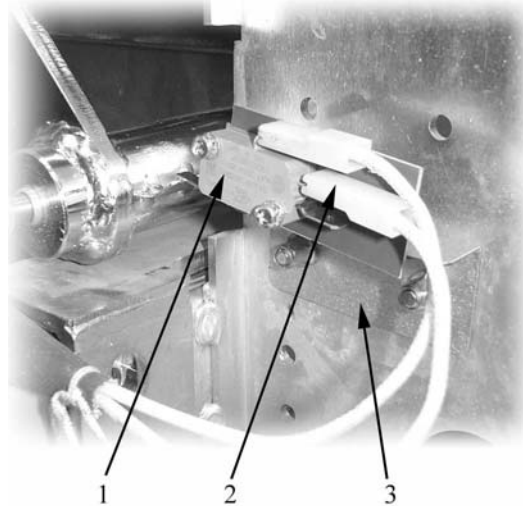

Fig. 20

1. Micro switch
2. Micro switch electrical connections
3. Micro switch support square

- remove the micro switch (item 1 in Fig. 20);
- follow the procedure in reverse to fix the new part.

6.16 Adjusting the micro switches

After any replacing, you must adjust the new micro switch.

To adjust the micro switch, proceed as follows:

- lower the tank completely;
- place the micro switch so the power supply for heating elements stops at the third turn of the handle when lifting tank.

6.17 Replacing the water filling valve

- remove the right angle and the right side as indicated in the related paragraphs;
- unscrew the fixing nut of the water column extension (pos. 2 in Fig. 21);
- lift the drain valve (pos. 2 in Fig. 1);
- unscrew the lock nut from the water column extension and slide the drain valve from the top;
- unscrew the water column extension from the faulty drain valve and replace it on the new part;
- replace it and follow the procedure in reverse to fix the new one in place.

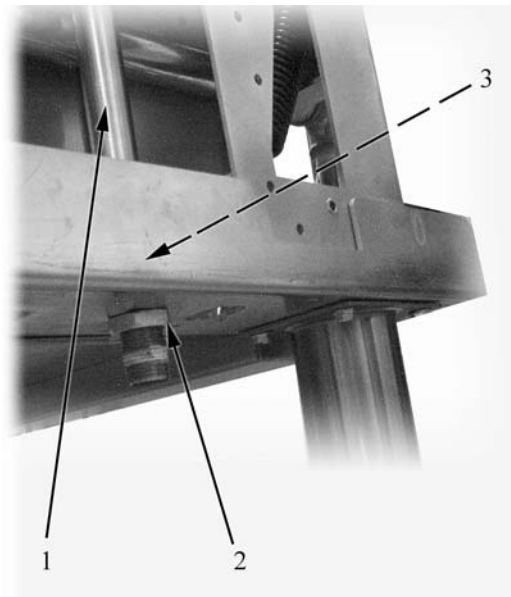

Fig. 21

1. Water column extension
2. Fixing nut of the water column extension
3. Fixing lock nut of the water column extension

6.18 Replacing the cover spring

- Remove the top as indicated in the related paragraph;
- lift the cover and prop it so to avoid the it can land;
- loosen the fixing nut (item 3 in Fig. 22) of the right or left spring tie (item 2 in Fig. 22) according to the spring to be replaced, until it is released completely;
- lower the cover;

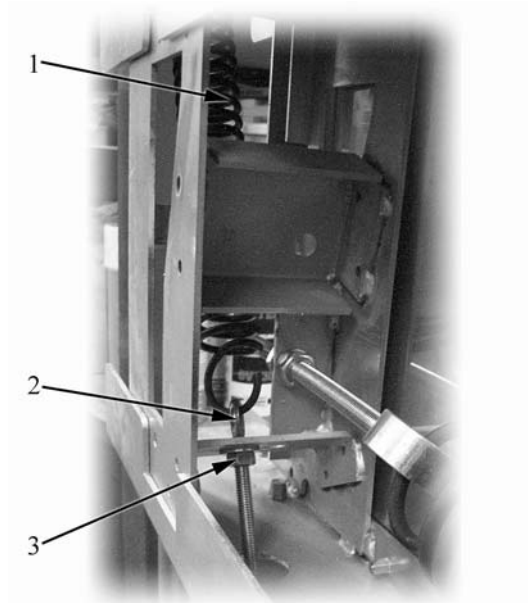
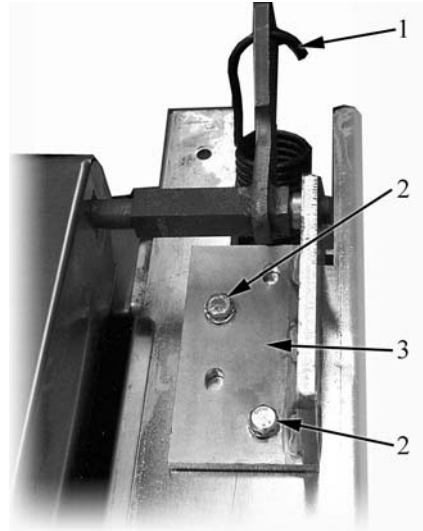

Fig. 22

1. Left spring
2. Spring tie
3. Fixing nut

Maintenance

- loosen the fixing screws (item 2 in Fig. 23) of the right or left cover support bracket (item 3 in Fig. 23) according to the spring to be replaced;
- lift the cover and release the spring;

**Fig. 23**

1. Right spring
 2. Bracket fixing screws
 3. Cover support bracket
- follow the procedure in reverse to fix the new part.

6.19 Replacing the lifting device of the spring

- Remove the left side as indicated in the related paragraph;
- lift the tank;
- loosen the fixing nut and lock nut (item 2 and item 1 in Fig. 24) of the spring tie (item 3 in Fig. 24) ;
- unlock the spring;
- follow the procedure in reverse to fix the new part.

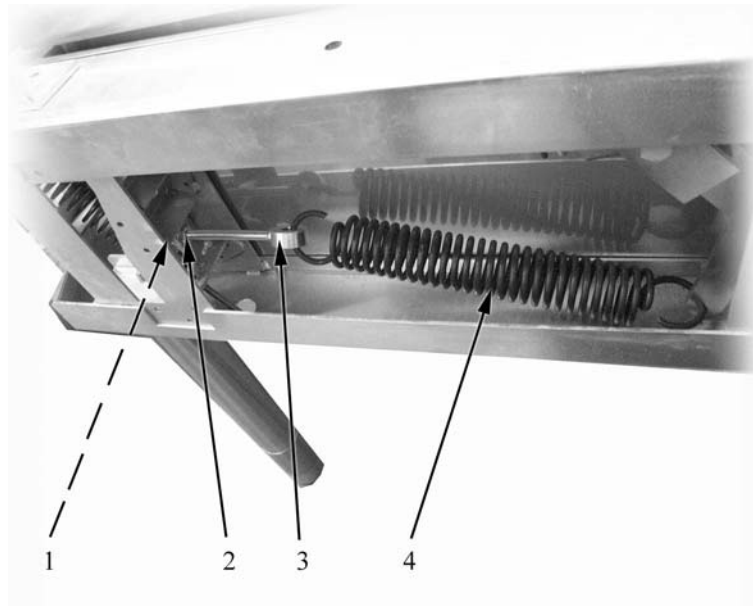

Fig. 24

1. Fixing lock nut
2. Fixing nut
3. Spring tie
4. Spring

6.20 Replacing the trapezoidal female screw

Lower the tank completely!

- Remove the left side and the left side as indicated in the related paragraphs;
- take off the plug (item 1 in Fig. 25) from the rod (item 2 in Fig. 25);
- remove the Seger ring (item 3 in Fig. 25);
- remove the washer (item 4 in Fig. 25);
- unscrew the fixing screws of the trapezoidal female screw (item 6 in Fig. 25);
- unscrew the trapezoidal female screw from the lifting rod (item 5 in Fig. 25);
- replace it and follow the procedure in reverse to fix the new one in place.

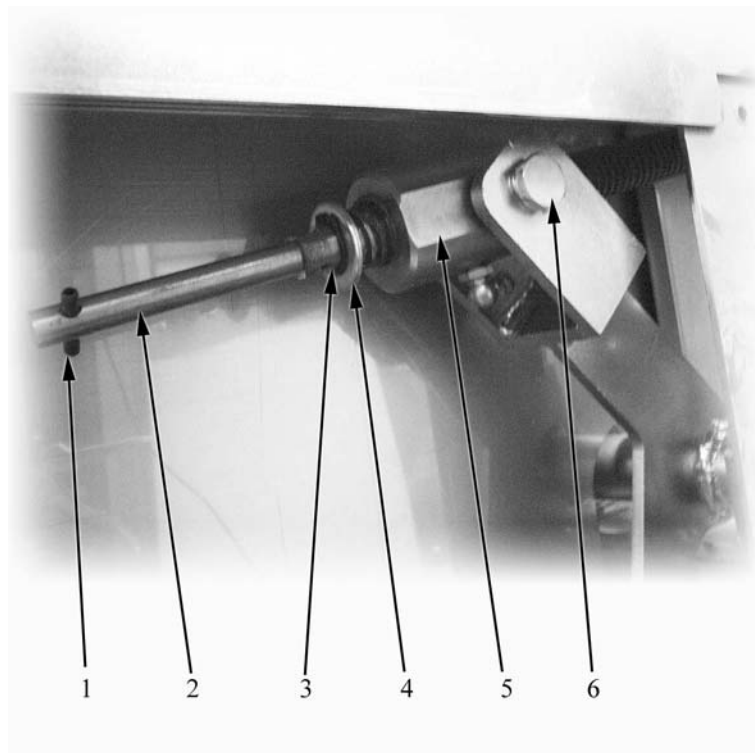

Fig. 25

1. Plug
2. Lifting rod
3. Seger ring
4. Washer
5. Trapezoidal female screw
6. Bushing fixing screws

6.21 Periodic greasing of the mechanical parts for tank movements

To keep the lifting and lowering devices of the tank in good conditions, it is necessary to carry out a periodic maintenance of these devices. The frequency shall be defined on the basis of operation number of the lifting/lowering tank.

- Lift the tank;
- remove the left angle as indicated in the related paragraph;
- grease the point indicated in item 1 in Fig. 26.
- apply a light coating of grease on the internal thread in item 2 in Fig. 26.

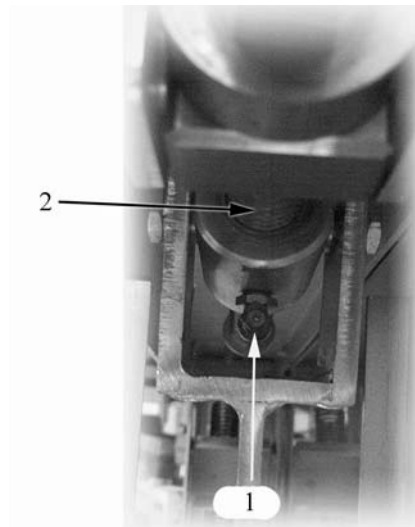

Fig. 26

1. Grease cup
2. Internal thread

7. Troubleshooting

If the appliance fails to work, check the fuse box for blown fuses (overload protection). Have the overload protection device checked by a qualified technician.

Users are not allowed to perform any maintenance operations on any parts of this appliance. Maintenance should be carried out by an authorised technician.

TROUBLE	CAUSE	MAINTENANCE	
		FOR THE USER	FOR THE TECHNICAL SUPPORT SERVICE
No hot tank heating:	No power	Check that the appliance is energized	
	tank lifted	lower the tank	
	Safety thermostat tripped		Reset the safety thermostat (see the related paragraph) and find the reasons that cause the maintenance
	Heating element break		Replace them
	Operating thermostat damaged		Replace it
	Electrical components or circuit are damaged		Check for the efficiency of circuit and components
	the micro switch is not sufficiently pressed		check for micro switch adjustment;
The temperature does not adjust	operating thermostat damaged		replacing the operating thermostat

8. Spare parts

Outer parts.....	42
Internal parts 1.....	44
Internal parts 2.....	46
Internal parts 3.....	48

8.1 Voltage codes

Voltage	Voltage code
A	3/N/PE~400/230V 50Hz
B	~250V 16A 50Hz
C	3/N/PE~380/220V 50Hz
D	3/PE~200V 50-60Hz
F	2/PE 220-240V 50Hz
G	3/N/PE~415/240V 50Hz
H	3/PE~230V 50Hz
I	3/PE~220V 60Hz
J	3/PE~380 50Hz
K	3/PE~400V 50Hz
L	3/PE~415V 50Hz
M	3/PE~440V 60Hz
N	3/PE~460V 60Hz
O	3/PE~480V 60Hz
P	1/N/PE~220-240V 50Hz
R	2/PE~220-230V 60Hz
S	3/N/PE~400/230V 50Hz
T	3/PE~230V 60Hz
U	1/N/PE~100V 50-60Hz

8.2 Product codes

Product code	Full name
Type codes	
100	9BR/E100
105	9BR/E105
100S	9BRS/E100
105S	9BRS/E105
Accessory codes	

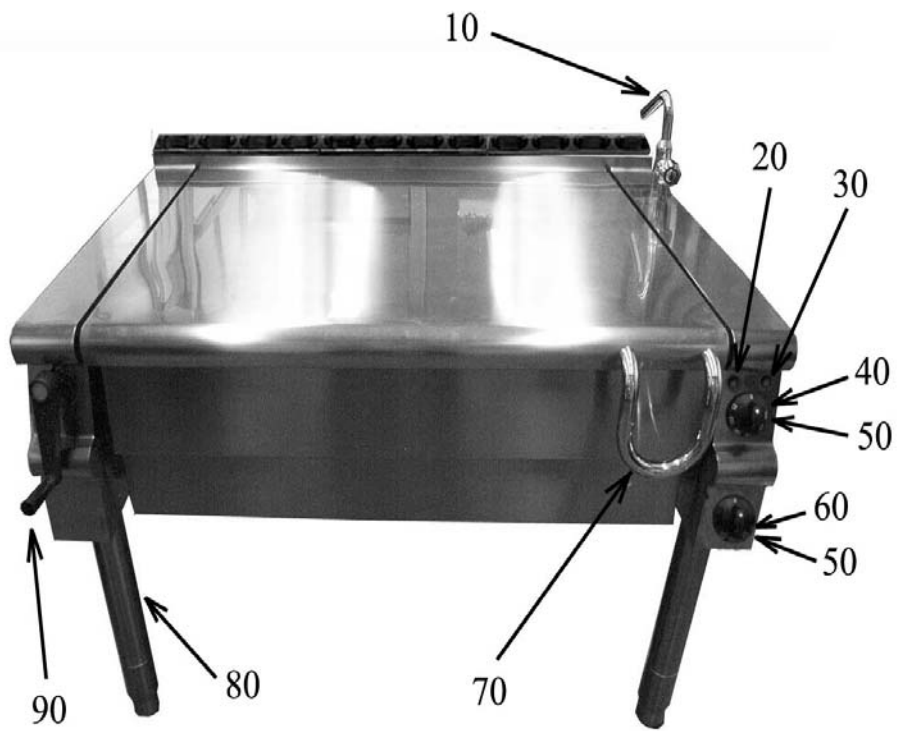

ID	Type	Voltage	Description	P-code
Module:Outer parts				
10			Water spout	826900260
20			White neon lens	6A038507
30			White neon lens	5A039207
40			Knob, thermostat	824710270
50			Knob gasket	2519490
60			Knob, power regulator	824710260
70			Handle	826430061
80			Foot	826490381
90			Handwheel	826900620

100=9BR/E100, 105=9BR/E105, 100S=9BRS/E100, 105=9BRS/E105

A=3/N/PE~400/230V 50Hz, H=3/PE~230V 50Hz

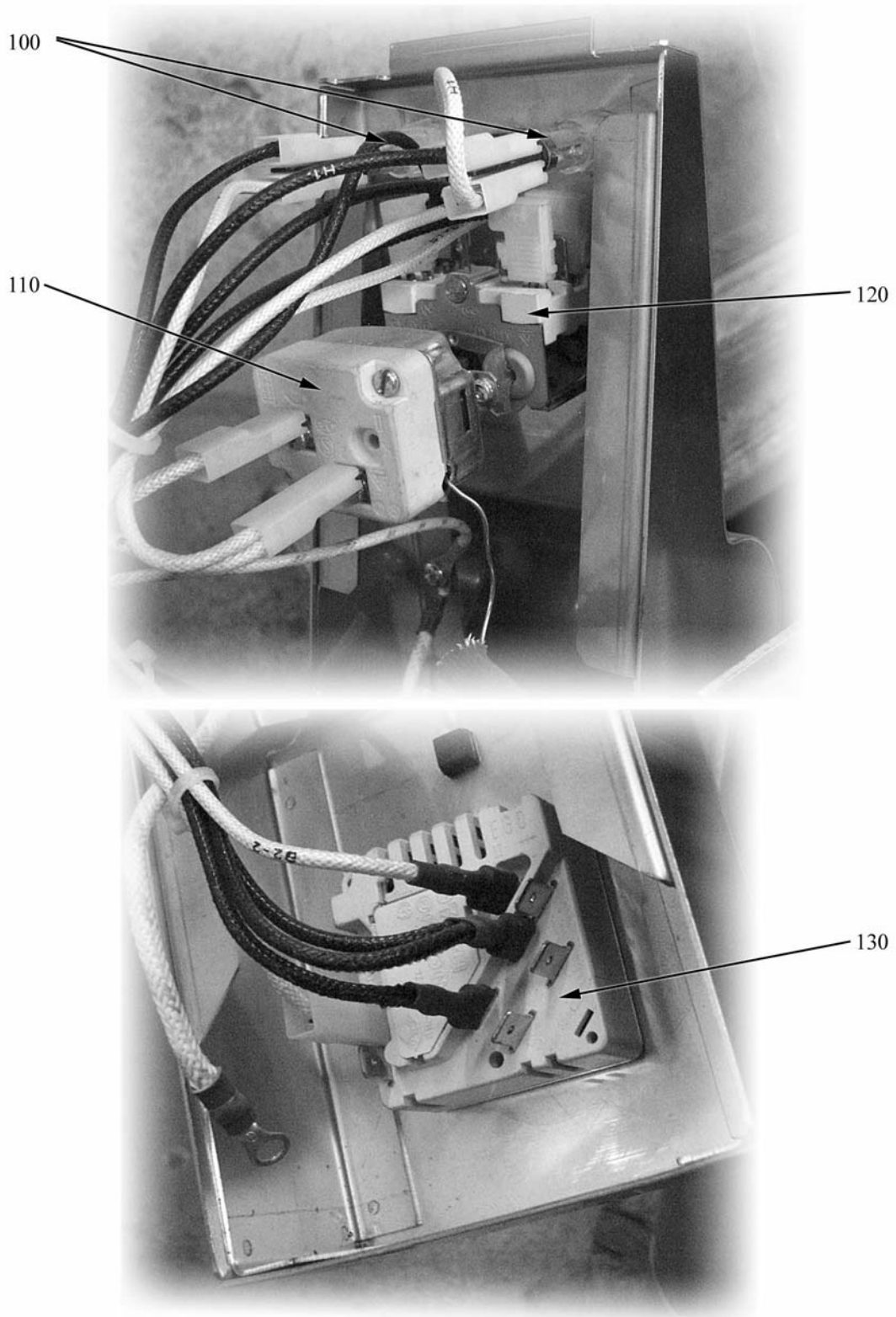

ID	Type	Voltage	Description	P-code
Module:Internal parts 1				
100			Neon	6A038506
110			Control thermostat	826630191
120			Switch	6A046000
130			Power regulator	6A049320

100=9BR/E100, 105=9BR/E105, 100S=9BRS/E100, 105=9BRS/E105

A=3/N/PE~400/230V 50Hz, H=3/PE~230V 50Hz

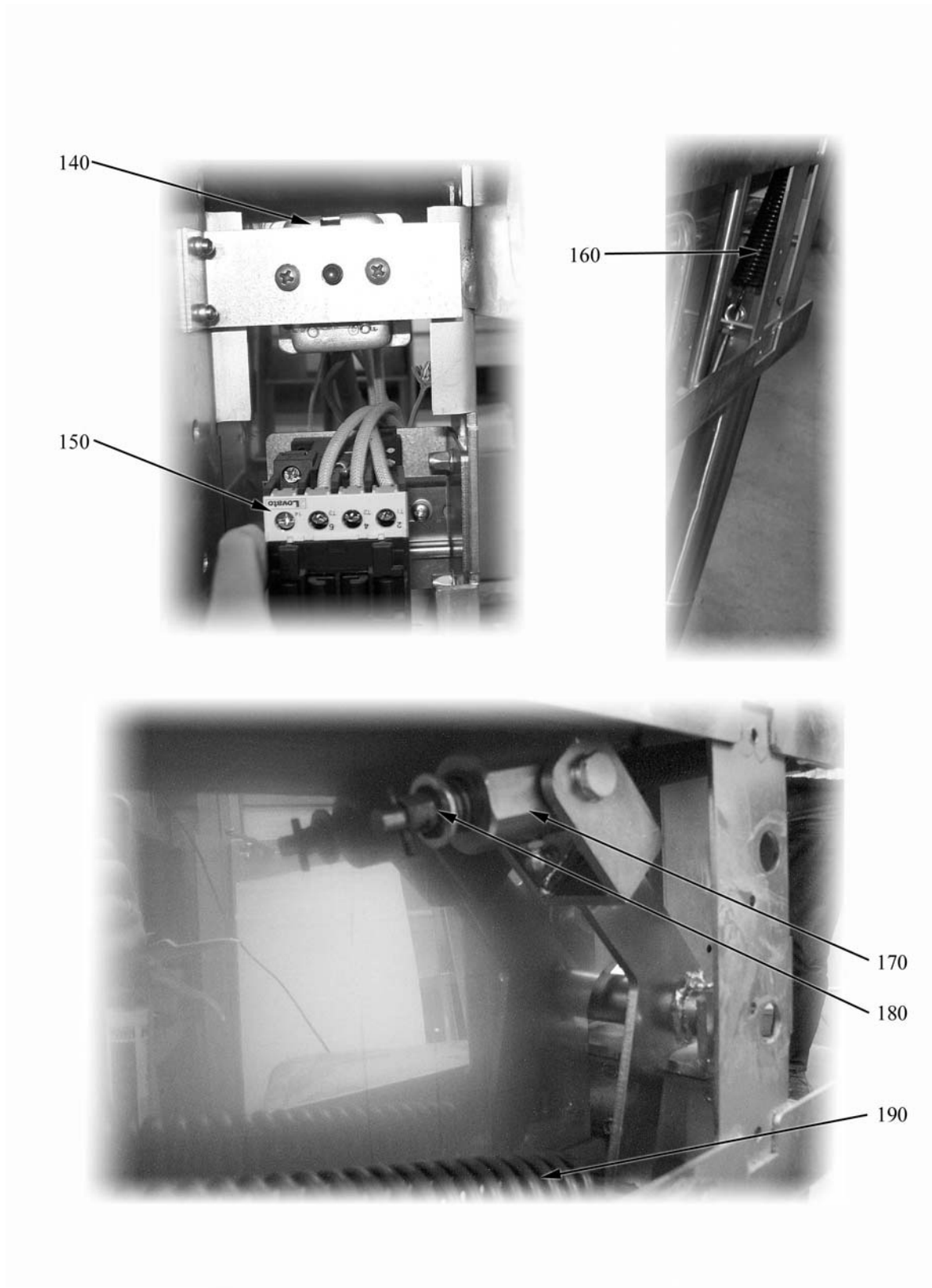

Spare parts

ID	Type	Voltage	Description	P-code
Module:Internal parts 2				
140			Safety thermostat	826630130
150			Contactora	826630300
160			Spring	823210031
170			Trapezoidal female screw	822160162
180			Ring Seger	8227979150
190			Spring	823210010

100=9BR/E100, 105=9BR/E105, 100S=9BRS/E100, 105=9BRS/E105

A=3/N/PE~400/230V 50Hz, H=3/PE~230V 50Hz

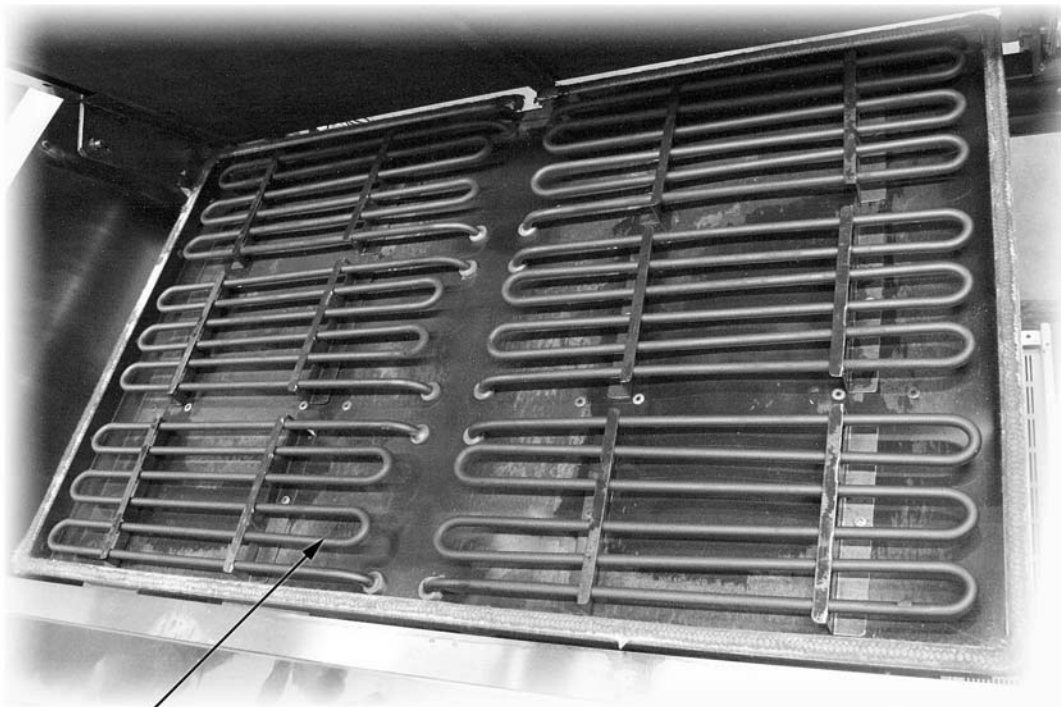

200

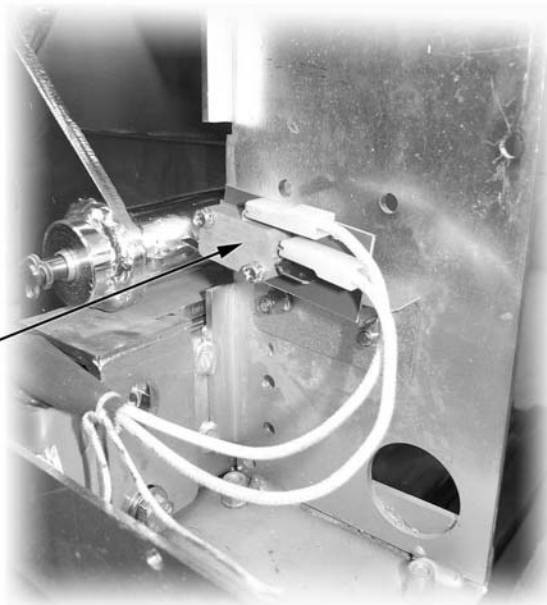

210

Spare parts

ID	Type	Voltage	Description	P-code
Module:Internal parts 3				
200			Heating element 2000 W	826620120
210			Micro switch	826630310

100=9BR/E100, 105=9BR/E105, 100S=9BRS/E100, 105=9BRS/E105

A=3/N/PE~400/230V 50Hz, H=3/PE~230V 50Hz

9. Technical specifications

Wiring diagrams..... 52

Installation Drawings..... 54

Technical specifications table..... 56

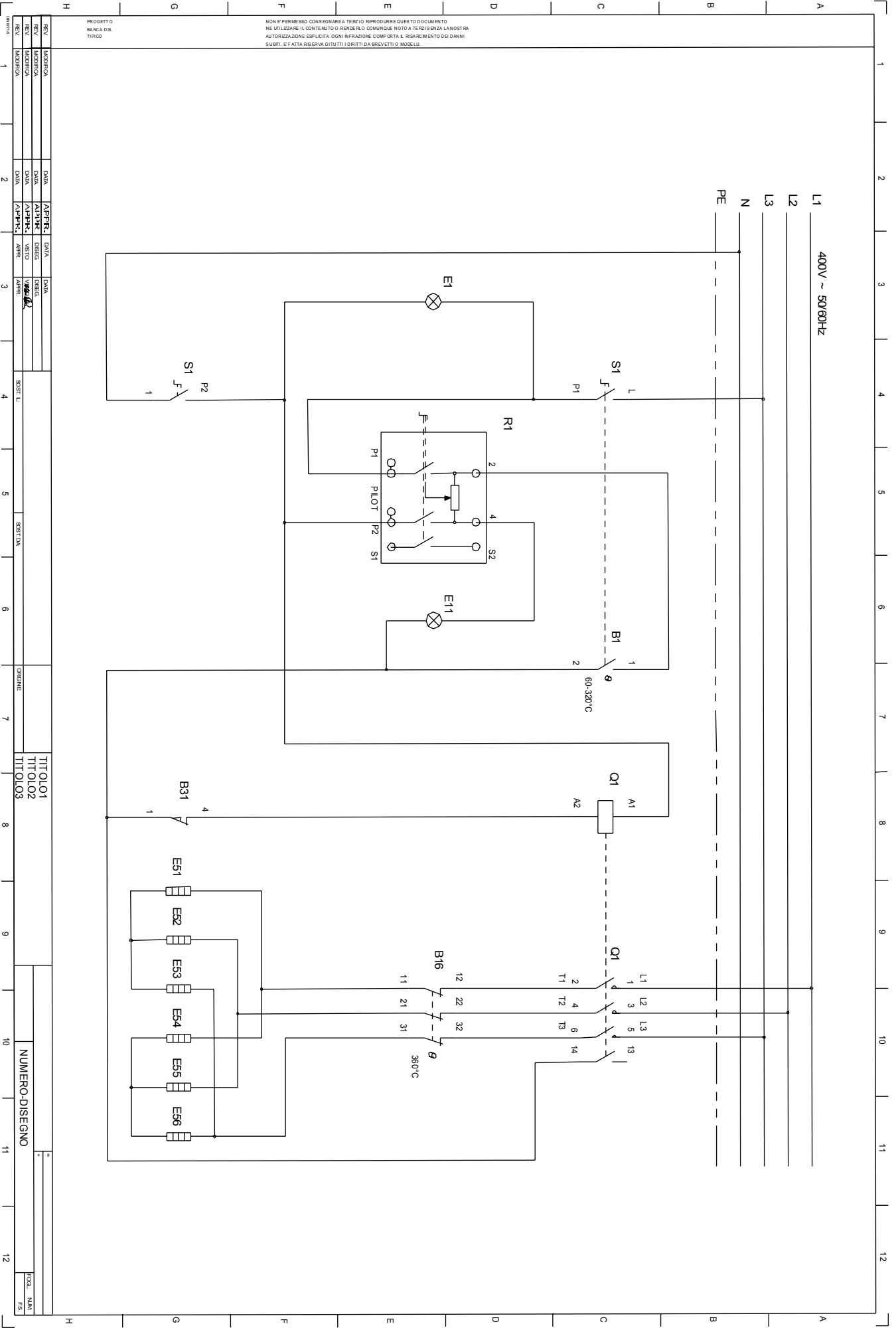

827SC0072: wiring diagram 9BR/E100, 9BR/E105, 9BRS/E100, 9BRS/E105 - 3/N/PE ~400V 50Hz

Technical specifications

827LE0072: key to wiring diagram 827SC0072			
-9BR/E100, 9BR/E105 ,9BRS/E100, 9BRS/E105 3/N/PE ~400V 50Hz			
Letter code	Codes	Descriptions	Specifications
E1	826650050	Line pilot lamp	400V - 150°C
E11	6A038506	Operation pilot lamp	400V - 150°C
E51-52-53-54-55-56	826620120	Heating element	2000W - 230V
B16	826630130	Safety thermostat	360°C - 3F
B1	826630191	Control thermostat	60 - 320°C - 1F
S1	6A046000	Switch	1F
Q1	826630300	Contactactor	25A
B31	826630310	Limit micro switch	
R1	6A049320	Energy regulator	230V - 13A

Installation Drawing 9BR/E100, 9BR/E105

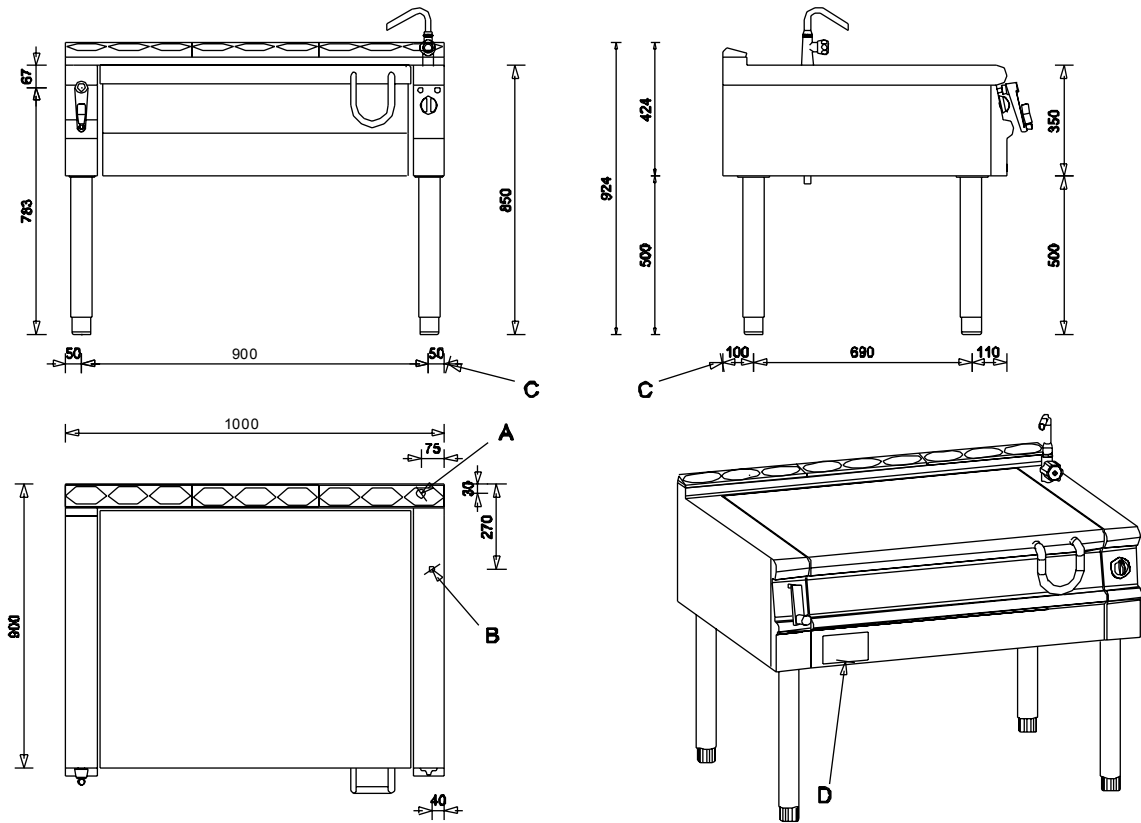

	DESCRIPTION
A	Electrical connection
B	Connecting cold water
C	Distance between feet
D	Rating plate

Installation Drawing 9BRS/E100, 9BRS/E105

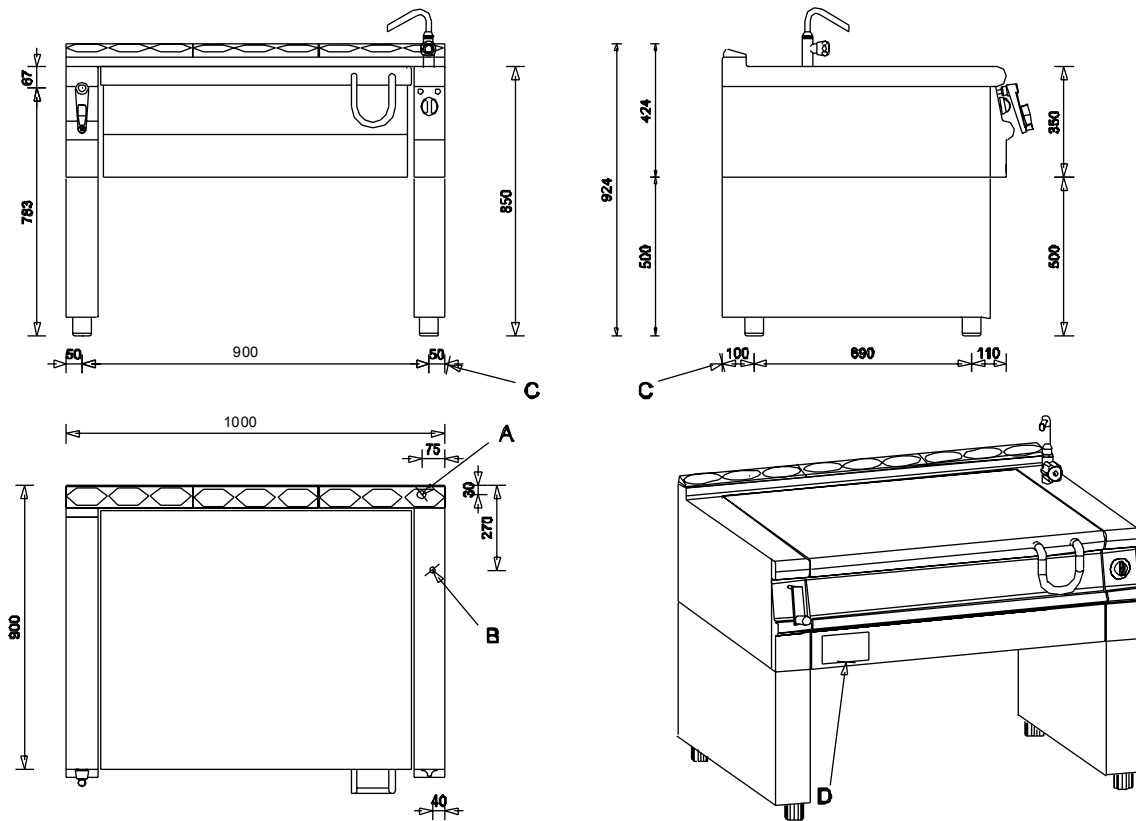

	DESCRIPTION
A	Electrical connection
B	Connecting cold water
C	Distance between feet
D	Rating plate

Technical specifications

Item	Type	Voltage	Specification
Volume with package			1.21 m ³
Total weight	100,100S		162 Kg
Total weight	105,105S		173 Kg
Cooking pan	100,100S		Inox
Cooking pan	105,105S		Compound
Tank dimensions (LxPxA)			730 x 630 x 170mm
Inner tank capacity			80 litri
Rated output			12 kW
Max. current		A	17.3 A
Max. current		H	30.1 A
Wire cross section		A	5 x 2.5 mm ²
Wire cross section		H	4 x 6 mm ²
Supply voltage		A	3/N/PE~400V 50 Hz
Supply voltage		H	3/PE~230V 50 Hz

100=9BR/E100, 105=9BR/E105, 100S=9BRS/E100, 105S=9BRS/E105

A=3/N/PE~400/230V 50Hz, H=3/PE~230V 50Hz

