



SERIE 900

Gas-heated Fryers

A.G.A. Approval No [7802](#)

Model. 9FRI/G420 - 9FRI/G820

AUSTRALIAN DISTRIBUTORS :
SCOTS ICE AUSTRALIA PTY LTD
UNIT 8/13 BERRY STREET
CLYDE, N.S.W 2142

FREE CALL : 1800 222 460
EMAIL : scotsice@bigpond.com
WEB : www.scotsice.com.au

INSTRUCTION FOR INSTALLATION, ADJUSTEMENT, USE AND MAINTENANCE

BN827730813AU

CONTENTS

1- INSTRUCTIONS FOR INSTALLATION	page 3
1.1 Identifying the models	page 3
1.2 Technical data	page 3
2 - GENERAL INSTRUCTIONS	page 3
2.1 Installation	page 3
2.3 Assembling	page 3
2.4 Aligning the equipment	page 3
2.5 Connecting to the gas supply	page 3
2.6 Electrical connections (for ranges with electric ignition of burners)	page 4
2.7 Grounding and bonding of the equipment (for ranges with electric ignition of burners)	page 4
2.8 Connecting the power cable to the unit's junction box	page 4
3 - ADAPTING THE FRYER TO OTHER TYPES OF GAS	page 4
3.1 Replacing the pilot burner nozzles	page 4
3.2 Replacing nozzles and air registers of the main burners	page 4
3.3 Conversion from natural gas to liquid gas	page 4
3.4 Conversion from liquid gas to natural gas	page 4
4 - STARTING	page 4
4.1 Checking the operation	page 4
4.2 Checking the thermal power	page 4
4.3 Checking the gas feeding pressure	page 4
5 - CHECK OF SOME MALFUNCTIONS	page 5
5.1 The pilot burner shows a difficult ignition or it fails to ignite	page 5
5.2 Extinction of pilot burner during the operation	page 5
5.3 The main burners show a difficult ignition or they fail to ignite	page 5
5.4 Difficult control of temperature	page 5
6 - REPLACING SOME COMPONENTS	page 5
Main burner - Pilot burner - Thermocouple - Ignition plug of pilot burner Gas valve - Safety thermostat	
7- USE AND MAINTENANCE	page 5
7.1 Warning	page 5
7.2 Safety devices	page 5
7.3 Use of the fryer	page 5
7.4 Lighting the burners	page 6
7.5 Extinction of burners	page 6
7.6 Draining the oil	page 6
8 - CLEANING AND MAINTENANCE	page 6
9 - LIST OF SPARE PARTS	page 6
10 - ENCLOSURES	page 7 - 12

1 - INSTRUCTIONS FOR INSTALLATION

1.1 Identifying the models

	Serie 900
Fryer with 1 basin of 20 litres 9FRI/G420	BN418031453220AU
Fryer with 2 basins of 20+20 litres 9FRI/G820	BN418031457420AU

1.2 Technical data

The technical data of these fryers are indicated in the **Tables T1-T2**(refer to the Enclosures).

2 - GENERAL INSTRUCTIONS

Read the instructions of this handbook carefully because they supply important information on installation, use and maintenance safety. Keep this handbook for any further reference of the various operators. The installation, transformation and maintenance of this equipment must exclusively be carried out by authorised installers or by licensed gasfitters complying with the [AS5601.1](#) Gas Installation standards and any local authority requirements in force.

The Manufacturer declines any liability if these rules are not complied with.

N.B. – This equipment complies with the CEI standard 61-50 and AS4551.

2.1 Installation

- After unpacking, check that the equipment is intact. In case of any doubt, do not operate this apparatus and call immediately a professional engineer.
- Arrange the packing elements far from children, because they can be dangerous.
- The equipment must definitively be installed in the position it occupies in the kitchen, preferably under an exhausting hood for a proper recirculation of air.
- The equipment must be installed only in rooms with good ventilation in accordance with the installation standards ([AS5601.1](#)).
- **Any commercial equipment of the type** must be installed only in rooms with a good exhaust system, according to the technical rules in force.
-Refer to the data plate on the appliance for relevant technical information e.g gas type, consumption, test point pressure, etc.
- These ranges can be installed separately, or assembled with other equipment of our line.
- This range is not available in built-in version.
- The equipment must be positioned at least 10 cm far from any wall surrounding it. Install the appliance in a non-combustable area. Ensure areas are suitably insulated if required in accordance with the installation standard ([AS5601.1](#)).
- The overall dimensions of the equipment are indicated in the following pages.

2.3 Assembling

- Remove the protection film from the outer surfaces of the apparatus. Clean these surfaces from probable residual adhesive using a proper solvent.
- Level the apparatus turning the proper adjustable feet.
- In stand-alone version, the fryer has a width of 40 cm and it must be fixed to the floor with the proper flanges (Fig. 2).

2.4 Aligning the equipment (Fig. 1)

Operate as follows:

- Remove the knobs and the control board of the top.

- Arrange the apparatuses side by side and level at the same height.
- Fasten the apparatuses with the proper screws, as shown in the fig. 1.

2.5 Connecting to the gas supply

Important!

- Clean the pipes to remove any dust, dirt or foreign matter which could block the supply.
 - Do not use pipes of a diameter smaller than that for which the appliance is designed. Ensure installation is "pipesized" for the whole installation.
 - After installation the pipework, connections and appliance(s) should be checked for gas leaks in accordance with standard operations. Use soapy water to check connections for leaks.
- Warning: Do not use naked flame to check for gas leaks!**
- Make certain the appliance is arranged for the type of gas to be used. Otherwise the appliance will have to be converted to the applicable gas type. If not certain contact local gas supplier for confirmation of gas type. Any conversion to be carried out must be undertaken by an authorised person in accordance with the supplied instructions.

- Use of Flexible Hoses: Where it is intended to connect the appliance to the gas supply using a flexible, it is important to use the correct type assembly for the application. Refer to [AS5601.1](#) for hose connection requirements. **The hose assembly must comply with AS/NZS 1869 Class B or D, be of appropriate internal diameter, be kept as short as possible (not to exceed 1.2 metres) and not be in contact with the floor.** A chain must be fitted to restrict the appliance movement to no more than 80% of the hose length.

- The section of the gas supply line must be sufficient to ensure the gas flow necessary for full operation of all of the appliances connected to the piping. Ensure an isolation valve and union is fitted at the inlet piping of the appliance.

For **Natural gas and LPG** appliances, the regulator supplied with the appliance must be fitted between the gas valve and the appliance inlet.

- The constant outlet pressure will be guaranteed by the gas pressure regulator that regulates varying inlet pressures.
- When the regulator is fitted, it must be adjusted to the correct pressure when the burners are operating.
Test point pressures are: 1.0kPa for Natural Gas
2.65kPa for L.P.G. (Propane)

- Make sure the appliance is suitable for the type of gas available, according to that given on the data plate.
- The supply pressure must be measured with the appliance operating, using a manometer (min 0.1kPa).
- Ensure gas is turned off.
- Remove control panel.
- Remove test point screw from the pressure test point and connect the manometer.

- Turn the gas on slowly, light the applicable burners and compare the value read on the manometer with that given on the data plate.
- If the manometer gives a pressure outside the range adjust the gas regulator supplying the appliance. If the pressure cannot be adjusted to the correct value check the installation to determine problem.

2.6 Electrical connections (for ranges with electric ignition of burners)

The equipment has been designed to operate at the voltage indicated on the rating plate, with a tolerance of $\pm 10\%$.

Each unit must be powered through a separate line properly sized. The connection must be carried out on the terminal board where this line arrives, through a flexible cable sheathed with rubber H05RN-F and protected by a stiff plastic or metallic pipe. Special circuit breakers of proper capacity, with a contact opening of at least 3 mm, as well as other protection devices against direct and indirect contacts of uncovered parts and against fault currents to the ground, must be connected according to the standards in force (maximum allowable leakage current: 1 mA/kW).

2.7 Grounding and bonding of the equipment (for ranges with electric ignition of burners)

Ground the equipment through the terminal marked with  on the terminal board where the line arrives.

Connect the metallic structure of any electric device to the terminal marked with bonding. 

2.8 Connecting the power cable to the unit's junction box

To access the power supply terminal block, proceed as follows

- disconnect power;
 - unscrew the terminal block cover fixing screws (item 1 in Fig. 16).
 - remove the terminal block cover (item 2 in Fig. 16).
 - The power lead should be locked in place with the cable clamp fitted on the appliance so as to avoid the risk of tearing it. The length of the ground (earth) cable should be such as to allow it to support any possible mechanical stress **after** the live leads.
- View table T3 for characteristics and section of cable.

3 - ADAPTING THE RANGE TO OTHER TYPES OF GAS

If the feeding gas is not among those prearranged, transform the equipment through the following operations.

Nozzles and rating plates are packed in a proper bag supplied with the equipment.

3.1 Replacing the pilot burner nozzles (Fig.5)

- Unscrew the union R or pos 1 and replace the nozzle UP with that indicated in the table T2.
- remove lower flue box cover (item 2 in Fig. 4) by unscrewing the fixing screws (item 1 in Fig. 4);
- Unscrew the thermocouple fixing nut (item 1 in Fig. 5a) and remove the thermocouple (item 2 in Fig. 5a);
- Unscrew the gas pipe fixing nut (item 5 in Fig. 5a) using a fixed spanner (wrench) to counterbalance the torsion;
- replace the pilot flame nozzle with the appropriate nozzle. When nozzle replacement is completed, check for proper operation of the appliance (see chapter "Check the operation" at the end of the previous section "Installation").

3.2 Replacing the main burner nozzles

- Open the doors;
- Remove the air sleeves (item 2 in Fig. 5) by removing the fixing screw (item 1 in Fig. 5).

c) remove the nozzle and replace it with the nozzle shown in the table T2".

d) After replacing the nozzle, you should adjust primary air shown in the table T2 (Fig. 3 pos. X – measure reference).

There is no need to adjust the minimum output as thermostat operation is of the "ON - OFF" type.

3.3 Conversion from natural gas to liquid gas

After changing the main burner and pilot flame nozzles and after adjusting the primary air (as shown in the table "T2

- exclude the pressure regulator on the gas valve (item 1 in Fig. 6)
- remove the threaded plug (item 1 in Fig. 6), loosen and remove the spring screw (item 1 in Fig. 7) and replace it with the accessory "exclusion plug", supplied with the nozzles, then tighten this accessory (item 1 in Fig. 8);

3.4 Conversion from liquid gas to natural gas

After changing the main burner and pilot flame nozzles and after adjusting the primary air as shown in the table "T2".

Loosen and remove the exclusion plug (Fig.8 - in position 1 Fig. 6) and replace it with the spring screw, supplied with the nozzles, then tighten the screw partially (item 1 in Fig. 7).

Connect the pressure gauge to the pressure port (item 2 in Fig. 6) and start up the appliance.

Check the pressure gauge shows the reduced pressure as shown in "Table T2 to reach this value, turn the screw (item 1 in Fig. 9) clockwise to increase the pressure and counterclockwise to decrease it.

After the adjustment, install the plug (item 2 Fig. 7 - in position 1 Fig. 6) remove the pressure gauge and replace the sealing screw. Check for leaks and check all the involved areas (see chapter "Connecting gas supply")

4 – STARTING (the Installer must test the operation of the fryer after installation, as below)

4.1 Checking the operation

Start the equipment according to the instructions of use, and check:

- the correct operation of pilot and main burners;
- that there are no leaks;
- the correct operation of room ventilation systems;
- the efficiency of the exhaust gas system; if necessary, refer to the paragraph 5 "Check of some malfunctions";
- whether the data of the rating plate of the equipment correspond to those of the gas pipe network.

Warning: during the operation, take extreme care in handling the hot areas of the outer surface.

4.2 Checking the thermal power

After installing the equipment and adapting it to another gas group or in any maintenance operation, check the thermal power.

- The thermal power rating is indicated in the tables T1 – T2.
- The equipment operates at the power rating when its nozzles actually correspond to the type of gas supplied and to the operating pressure indicated in the tables T1 and T2.

4.3 Checking the gas feeding pressure

- Necessary measuring instrument: pressure gage with minimum accuracy rating of (min 0.1kPa)..
- Open the door of the compartment under the cooking basin
- Remove the frontal panel with the relatives commands, and connect the pipe of the pressure gage to this tap. (item 1 Fig.10)
- Carry out the measurement while the equipment is operating.

- The measured value must be included within the limits indicated in the table T1; otherwise, stop the test and call the gas service company.
- Disconnect the pipe of the pressure gage and screw down the screw of the pipe tap tightly.

5 - CHECK OF SOME MALFUNCTIONS

5.1 The pilot burner shows a difficult ignition or it fails to ignite

- The piezoelectric lighter, the ignition plug or the pilot burner cable are faulty.
- Insufficient gas feeding pressure.
- Nozzle or pipe clogged.
- The gas valve is faulty.

5.2 Extinction of pilot burner during the operation

- The thermocouple is faulty, or it is not properly heated, or not correctly connected to the gas valve.
- Gas feeding pressure drop.
- Intervention of the safety thermostat of manual reset (refer to the point 6.4)
- The gas valve is faulty.

5.3 The main burners show a difficult ignition or they fail to ignite

- Insufficient gas feeding pressure.
- Nozzles clogged.
- The gas valve is faulty.
- Intervention of the safety thermostat of manual reset (refer to the point 6.4).

5.4 Difficult control of temperature

- Working thermostat faulty

6 - REPLACING SOME COMPONENTS

N.B.: The sealed components must not be tampered with. After any operation, check that there are no leaks, if necessary.

Warning! Service work must only be carried out by Authorised Persons.

6.1 Main or pilot burners

- Open the doors of the compartment under the cooking basin.
- Replace the component.

6.2 Thermocouple, high-voltage ignition cable

- Open the doors of the compartment under the cooking basin.
- Remove the control board.
- Disconnect this component from the gas valve
- Remove and replace the component.

6.3 Gas valve

- Open the doors of the equipment, drain all the oil from the concerned basin (refer to the paragraph 7.6 - Draining the oil).
- Remove the control board.
- Disconnect the pipes and the thermocouple of the valve and replace the valve.

6.4 Safety thermostat

Before enabling the safety thermostat **TS** (fig. 11) again, eliminate the reasons provoking the overheating: examine the functioning of the operating thermostat, the oil level, etc... Then carry out the following operations:

- Open the doors of the equipment
- Press the red pushbutton of the thermostat. (Fig 11 pos. 1)

- Check whether the electric circuit of the thermocouple is closed.

Replace the safety thermostat through the following operations:

- Open the doors of the equipment, drain all the oil from the concerned basin (refer to the paragraph 7.6 - Draining the oil).
- Unscrew the stuffing box from the frontal panel of the basin, to extract the bulb of the thermostat having to be replaced.
- Disconnect the electrical connections of the thermocouple and replace the thermostat.

Remplace the working thermostat operations

- Open the doors of the equipment, drain all the oil from the concerned basin (refer to the paragraph 7.6 - Draining the oil).
- Unscrew the stuffing box from the frontal panel of the basin, to extract the bulb of the thermostat having to be replaced
- Disconnect the electrical connections of gas valve control circuit and replace the thermostat.

7 - USE AND MAINTENANCE

7.1 Warning

This equipment has been designed for professional aims, therefore it must be operated exclusively by trained personnel.

It must exclusively be used to fry food; consequently any other use is improper. Before switching on the cooker, clean all its surfaces in contact with food, with the utmost care.

ATTENTION ! Never switch on the fryer when its basins have no oil. When using cakes of fat, first of all melt them adjusting the temperature to the MINIMUM (turn the knob M of the fig. 13 pos 2 Never exceed the maximum level of oil marked inside the basin.

It is better to attend the equipment during the operation, because possible faults of the safety devices could provoke the overheating of the oil contained in the basin, that becomes inflammable at high temperatures.

Dip the basket with the food to fry, slowly into the boiling oil taking care that the froth being generated does not overflow from the rim of the basin. If this happen, stop dipping the basket for some seconds.

The installation and possible transformation of these fryers for other gas groups must be carried out only by authorized and qualified installers.

In case of troubles, close the gas cutoff cock, installed before the equipment.

For any repair, call the authorized After-Sales Service and require only original spare parts.

Not complying with these instructions may seriously compromise the safety of this equipment; the manufacturer declines any liability in case these warnings are not complied with.

WARNING

**Do Not store flammable materials in or near this appliance
Do not spray aerosols in the vicinity of this appliance while it is in operation.**

7.2 Safety devices

Any basin of these fryers is provided with a safety thermostat. When the maximum control temperature is exceeded, this thermostat cuts off the gas flow. When this occurs, close the cutoff cock installed before the equipment, and call an After-Sales Centre.

7.3 Use of the fryer (fig. 12 and 13)

The knob **M** (fig. 12) of the valve is marked with the following symbols:

- 0** **Burner off** (fig. 12 pos 1)
- *** **Pilot burner on and off** (fig. 12 pos 2)
-  **Lighting the main burners** (fig. 12 pos 3)

The knob **M** (fig. 13) of the thermostats is marked with the following symbols

- 0** **Burner off** (fig. 13 pos 1)
- 130** **Minimum temperature** (fig. 13 pos 2)
- 190** **Maximum cooking temperature** (fig. 13 pos 3)

7.4 Lighting the burners (fig. 12 and 13)

- Fill the basin with oil until its level is above the minimum mark and below the maximum (fig. 14).
- Turn the knob **M** to *****. (Fig. 12 pos 2)
- Press the knob completely and light the pilot burner
After lighting, keep the knob pressed for approximately 20 seconds (observe the pilot burner opening the doors of the equipment).
- In case of extinction of the pilot burner, repeat this operation.
- Turn the knob **M** to the position corresponding to  (Fig. 12 pos 3)
- Then turn the knob on the position of the desired temperature (Fig.13)

7.5 Extinction of burners (fig. 12)

- Switch off the main burner turning the knob **M** to the position 2, (fig.12) only the burner pilot will remain lit up
- Switch off the pilot burner turning the knob **M** to the position 0 (fig.12 pos.1)

7.6 Draining the oil

- The oil drain tap **S** (fig. 10) one tap per basin - is installed inside the compartment under the cooking basins, in a safe position so that it cannot accidentally be opened during the operation.
- Install on the drain tap the extension supplied with the appliance
- When draining the basin, put the proper tray (or other vessels being able to contain the quantity of oil to be drained at high temperature) under the drain cock.

8 - CLEANING AND MAINTENANCE

- Wash the surfaces of stainless steel with water and non abrasive detergents, every day; then rinse abundantly and wipe carefully.
- When cleaning stainless steel, never use detergents with abrasive substances, nor steel wool, brushes or scrapers of common steel.
- Clean the floor under the fryer with non corrosive products.
- **Do not wash the equipment with water jets.**

When the equipment must not be used for long time, comply with the following instructions:

- Close the gas cutoff cock, installed before the equipment.
- Clean all the surfaces carefully.
- Protect the surfaces of stainless steel laying off a light film of white mineral oil with a cloth.

Ventilate the rooms periodically.

Check the equipment periodically (at least once a year); this check must be carried out by qualified professional personnel. Drawing up a maintenance contract is recommended.

It is recommended the appliance be visually checked for problems each week and the appliance be serviced by an authorised service person at least every 12 months or as may be required. This is not covered by warranty.

9 - LIST OF SPARE PARTS

- Gas control valve
- Pilot burner
- Main burner
- Thermocouple
- Ignition plug of pilot burner
- Safety thermostat
- Working thermostat
- Piezoelectric lighter
- Oil drain cock.

T1 Serie 900

Modelli - Modelle - Models Codice Code	9FRI/G420 9FRI/G820 BN418031453220AU BN418031457420AU
Q Mj	
Consumo gas** Nat Gas 1 kPa	70 MJ/h 140 MJ/h
L.P.G 2,65 kPa	60 MJ/h 120 MJ/h
Tipo - Bauart - Type	B₁₁

** Consumo gas - Gasverbrauch - Gas consumption - Consommation du gaz - Gasverbruik

* Connessione gas - Gasanschluss - Arrivée gaz - Verbindung

Per installazione in Danimarca occorre avvitare sulla rampa d'alimentazione l'apposito nipplo.

Vor dem Anschluß an die Gasversorgungsanlage, ist es erforderlich, den als Ausstattung gelieferten passenden Nippel auf Versorgungsrampe gas einzuschrauben.

T2 Serie 900

Gas	P kPa	Modelli-Modelle-Models Modèles-Modellen	9FRI/G420	9FRI/G820	
Nat Gas	1	Ugelli pilota ②	32.2	2 x 32.2	
		Ugelli bruciatore ③	2 x 2.60mm	4 x 2.60mm	
		Pressione ridotta ④	1.0 kPa	1.0 kPa	
		A= mm ⑤	45	45	
L.P.G	2,65	Ugelli pilota ②	16.2	2 x 16.2	
		Ugelli bruciatore ③	2 x 1.50mm	4 x 1.50mm	
		Pressione ridotta ④	2.65 kPa	2.65 kPa	
		A= mm ⑤	33	33	

② Ugello pilota - Zündbrennerdüse - Pilot burner nozzle - Injecteur de la veilleuse - Gaspitten pilot

③ Ugello bruciatore - Brennerdüse - Burner nozzle - Injecteur du bruleûr - Gaspitten brander

④ Pressione ridotta - Vermindertem Druck - Réduction de la pression - test point pressure

⑤ A= Regolazione aria primaria - Primärluftabstand - Primary air adjustment - Regulation de l'air - Regeling aanfangslucht

T3 Serie 900

Modelli - Models - Modèles Modelle - Modellen	Alimentazione elettrica - Power supply - Speisung Alimentation électrique - Elektrische voeding		
	V	W	Cavo - Cable - Kabel H07RN - F mm ²
9FRI/G420 - BN418031453220AU 9FRI/G820 - BN418031457420AU	240V~ 1N - 50 Hz	10	n° 3 x 1 mm ²

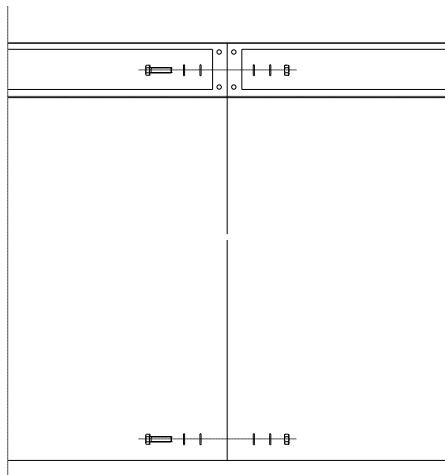

Fig.1 - Abb. 1

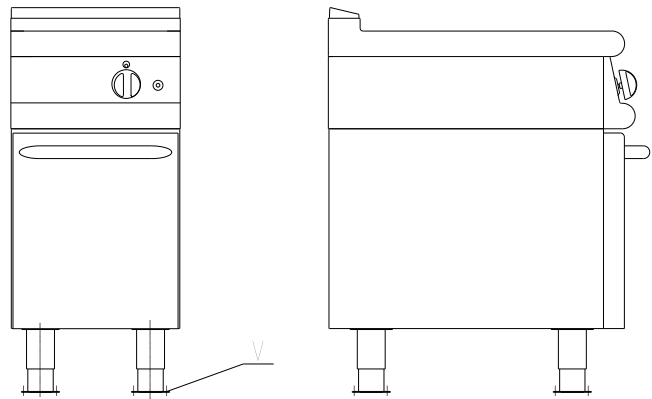

Fig..2 - Abb.2

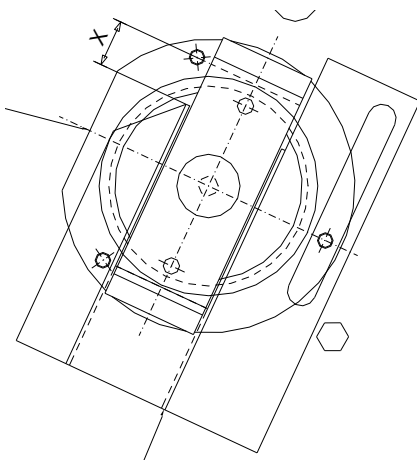

Fig.3 - Abb. 3

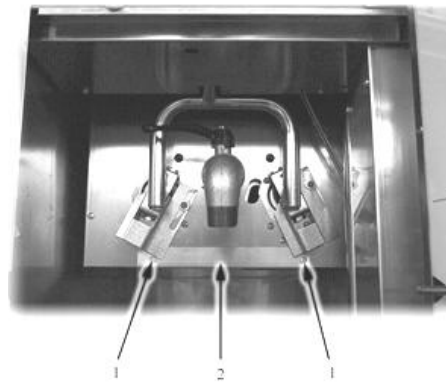

Fig. 4 - Abb. 4



Fig. 5 - Abb. 5

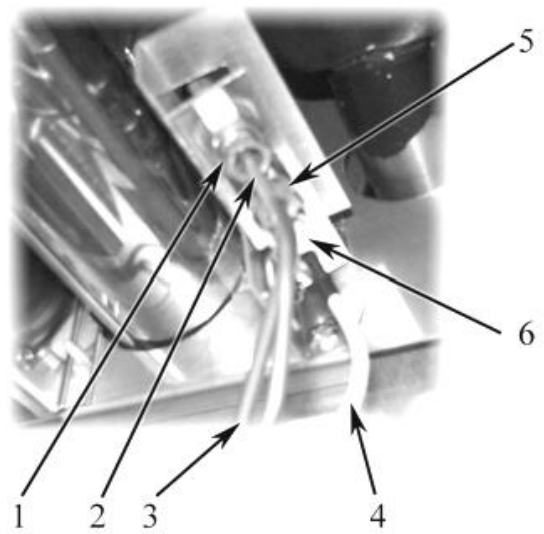

Fig. 5a - Abb. 5a

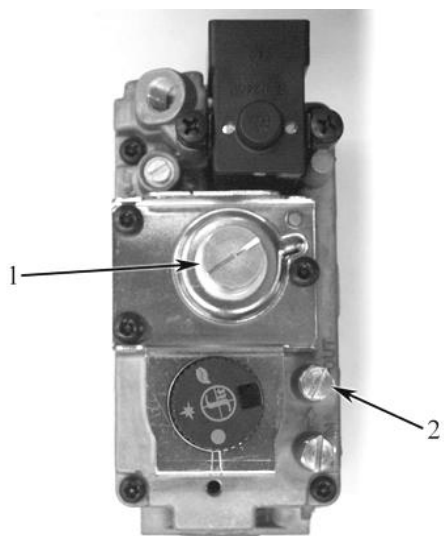

Fig. 6 - Abb. 6

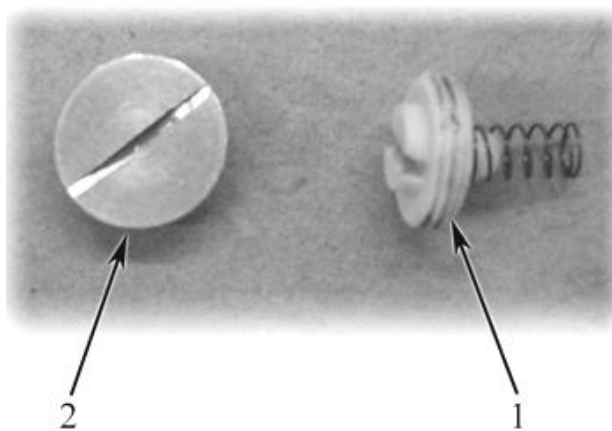

Fig. 7 - Abb. 7

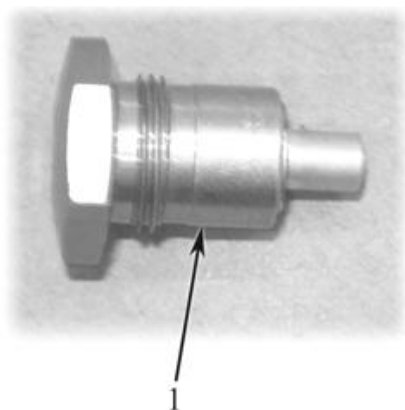

Fig. 8 - Abb. 8

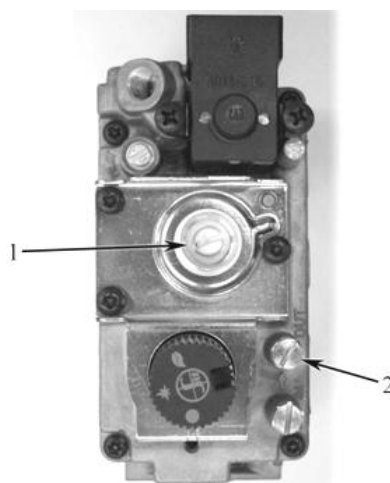

Fig. 9 - Abb. 9

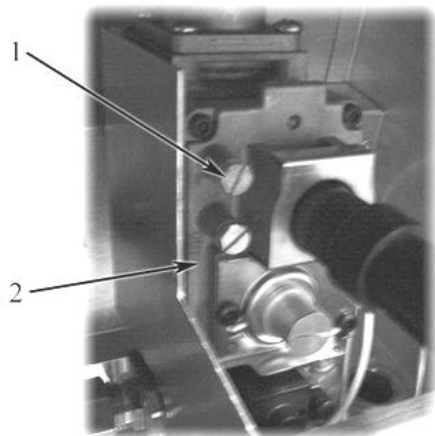

Fig. 10 - Abb. 10



Fig. 11 - Abb. 11

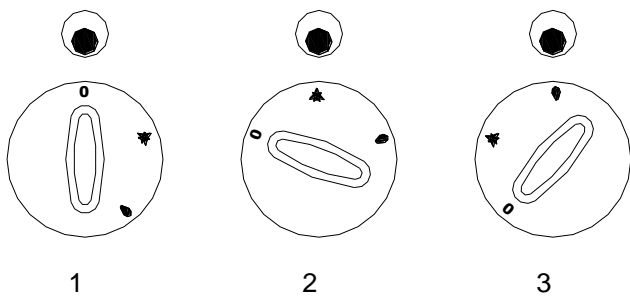

Fig. 12 Abb. 12

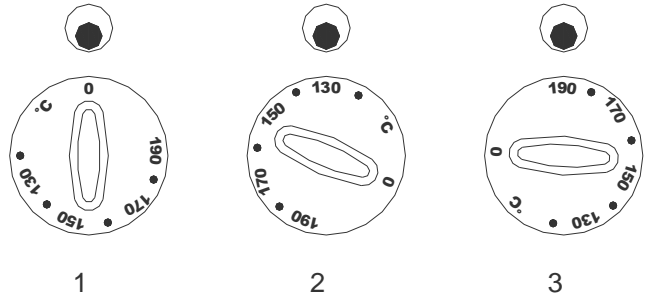

Fig. 13 Abb. 13

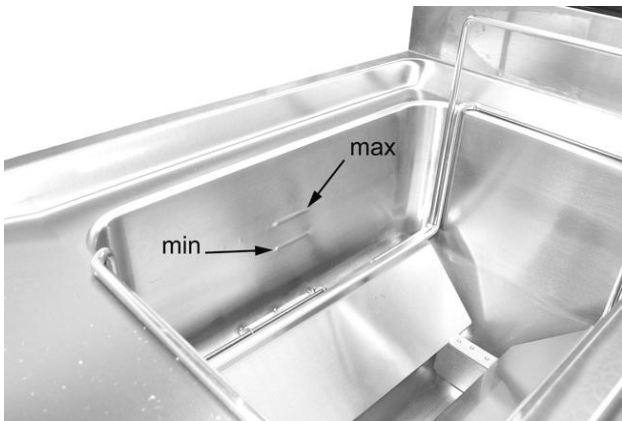

Fig. 14 - Abb. 14



Fig. 15 - Abb. 15

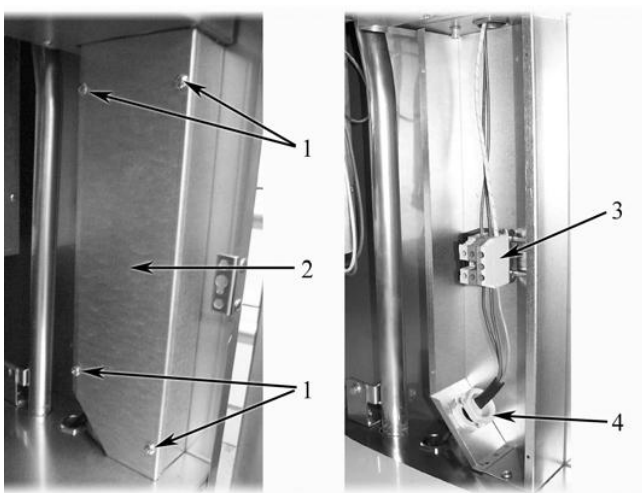
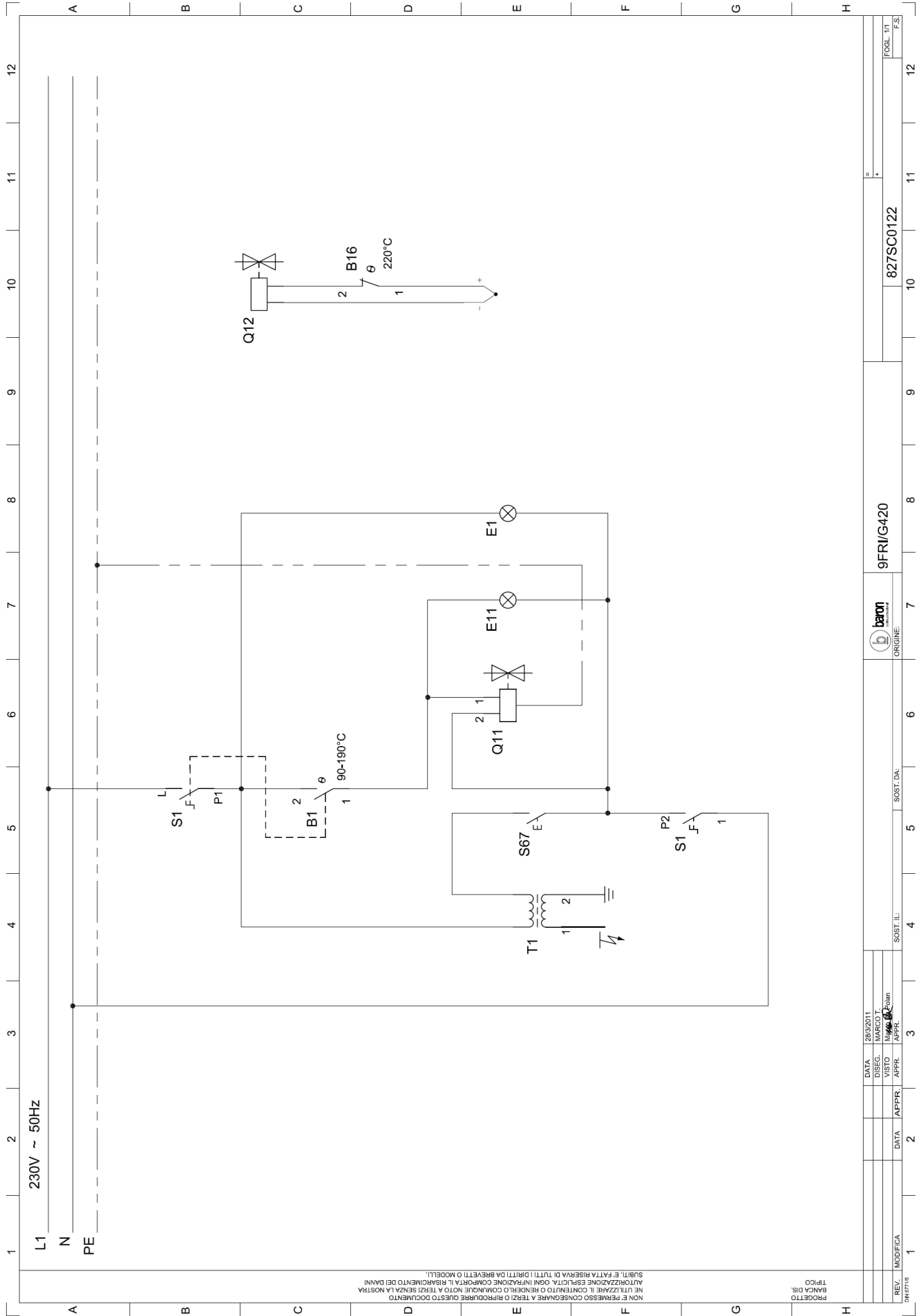

Fig. 16 - Abb. 16



NON E' PERMESSO CONSEGNARE A TERZI O RIPRODURRE QUESTO DOCUMENTO
 NE UTILIZZARE IL CONTENUTO O RENDERSI COME NOTO A TERZI SENZA LA NOSTRA
 AUTORIZZAZIONE ESPLICITA' O IN FRAZIONE COMPERTA. IL RISARCIMENTO DEI DANNI
 SUGGERITI, E FATTA RISERVA DI TUTTI I DIRITTI DA BREVETTI O MODELLI.

PROGETTO
 BANCA DIS.

REV.	MODIFICA	DATA	APPR.	APPR.	SOST. IL:	SOST. DA:	ORIGINE:

DATA	28/03/2011
DISSEG.	MARCO T.
VISTO	MARCO T.
APPR.	

9FRI/G420	827SC0122
-----------	-----------

F	12
F	11
F	10
F	9
F	8
F	7
F	6
F	5
F	4
F	3
F	2
F	1

FOGL. 1/1

F.S.

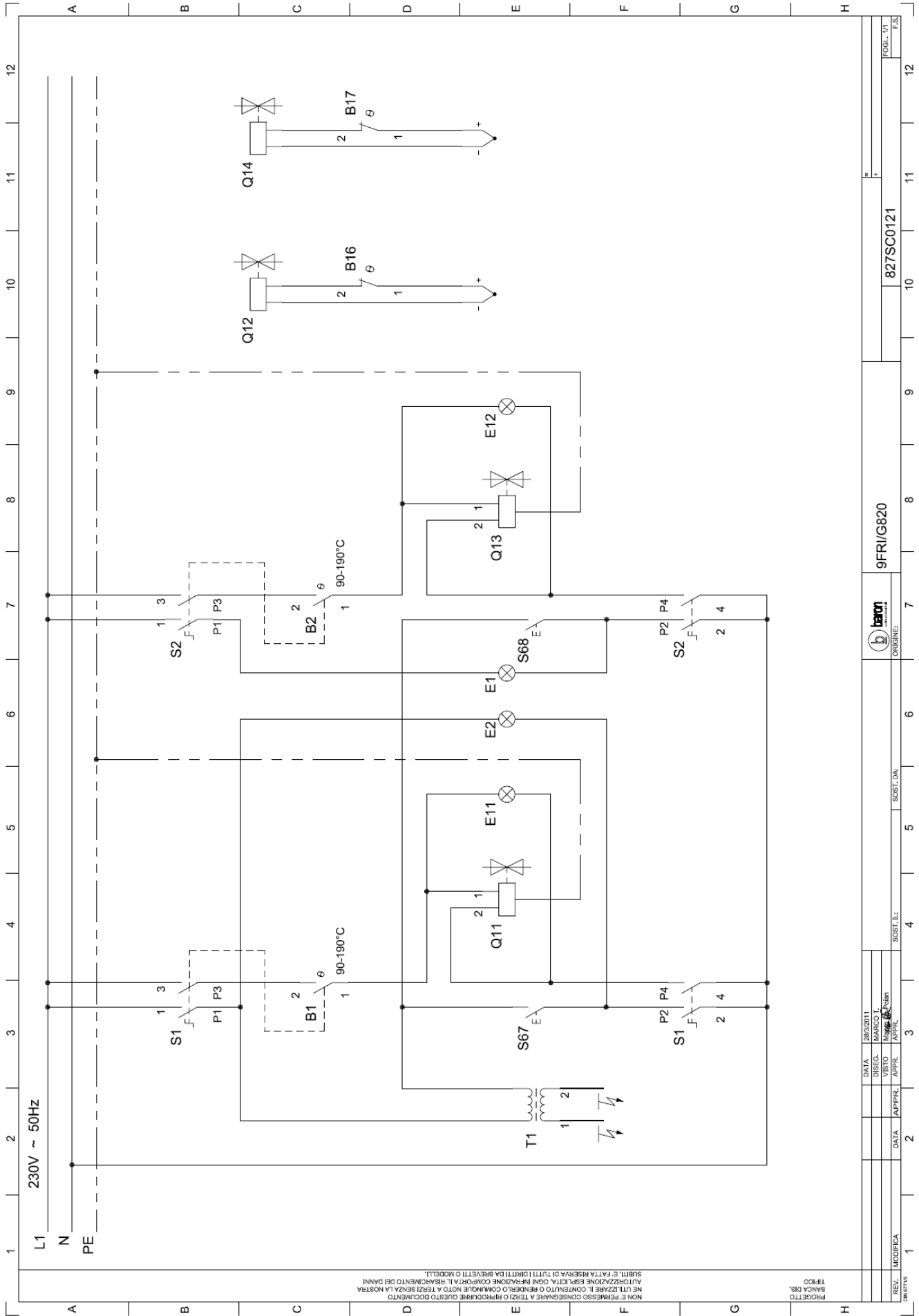

NON È PERMESSO CONSERVARE A TERZI O RIPRODURRE QUESTO DOCUMENTO
 NE UTILIZZARE IL CONTENUTO O RENDERSI COMPLICI A TERZI SENZA LA MOSTRA
 AUTORIZZAZIONE ESP. RTA. CON INPAZIONE COMPLETA IL RISARCIMENTO DEI DANNI
 SUITI, E FATTA RISERVA DI TUTTI I DIRITTI DA BREVETTI O MODELLI.

PROGETTO
 BANCA DIS.
 TRFO

REV.	MODIFICA	DATA	APPRE.	APPR.	SOST. LI.	SOST. DA.	ORIGINE:
01		28/03/2011	BARON	BARON			9FRI/G820

827SC0121	
FOGL. 1/1	F.S.

827SC0121	
FOGL. 1/1	F.S.

9FRI/G420

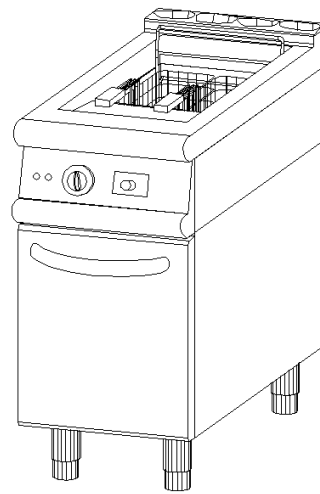
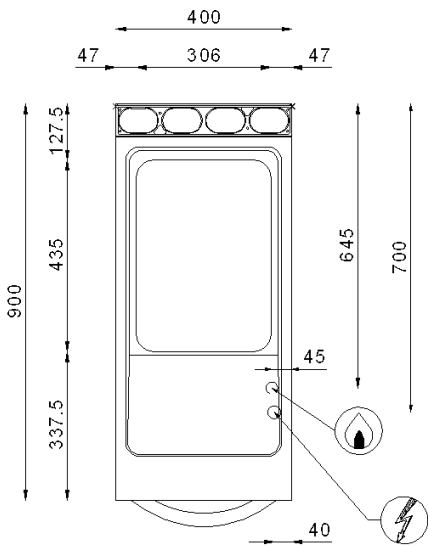
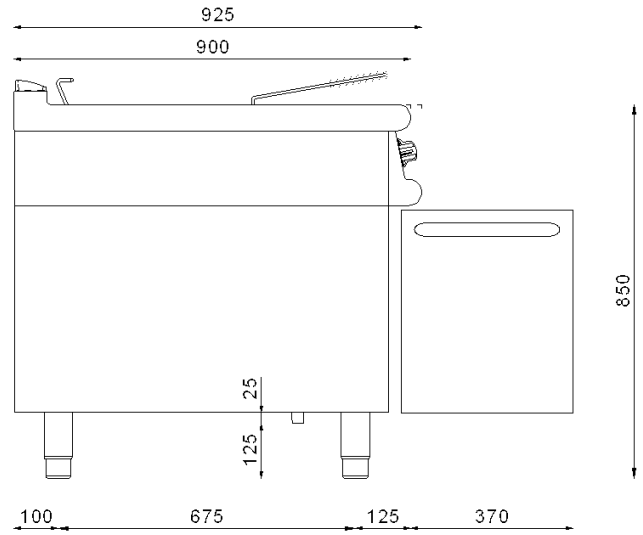
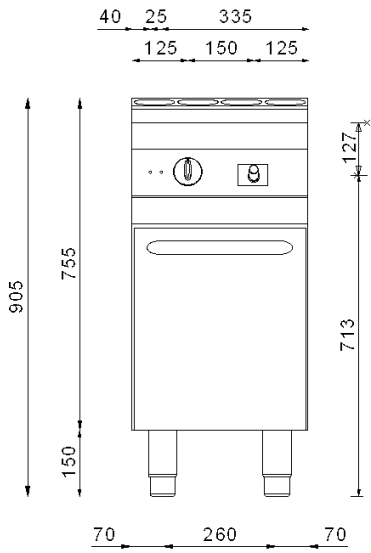

9FRI/G820

