



SERIE 700

Gas-Frytops

A.G.A. Approval No. 6782

| | | | |
|------------------|------------|------------|------------|
| Model : 7FT/G400 | 7FTT/G400 | 7FT/G410 | 7FTT/G410 |
| 7FTT/G405 | 7FTT/G415 | 7FTV/G400 | 7FTTV/G400 |
| 7FTV/G410 | 7FTTV/G410 | 7FTTV/G405 | 7FTTV/G415 |
| 7FT/G800 | 7FTT/G800 | 7FT/G810 | 7FTT/G810 |
| 7FT/G820 | 7FTT/G805 | 7FTT/G815 | 7FTT/G820 |
| 7FTT/G825 | 7FTV/G800 | 7FTTV/G800 | 7FTV/G810 |
| 7FTTV/G810 | 7FTV/G820 | 7FTTV/G820 | 7FTTV/G805 |
| 7FTTV/G815 | 7FTTV/G825 | | |

AUSTRALIAN DISTRIBUTORS :
 SCOTS ICE AUSTRALIA PTY LTD
 UNIT 8/13 BERRY STREET
 CLYDE, N.S.W 2142

FREE CALL : 1800 222 460
 EMAIL : info@scotsice.com.au
 WEB : www.scotsice.com.au

INSTRUCTION FOR INSTALLATION, ADJUSTEMENT, USE AND MAINTENANCE

CONTENTS

| | |
|--|------------|
| 1- INSTRUCTIONS FOR INSTALLATION | page 3 |
| 1.1 Identifying the models | page 3 |
| 1.2 Technical data | page 3 |
| 2 - GENERAL INSTRUCTIONS | page 3 |
| 2.1 Installation | page 3 |
| 2.5 Assembling | page 3 |
| 2.6 Assembling the fry-top on a neutral base | page 3 |
| 2.7 Aligning the equipment | page 3 |
| 2.9 Connecting to the gas supply | page 3 |
| 4 - STARTING | page 4 |
| 4.1 Checking the operation | page 4 |
| 4.2 Checking the thermal power | page 4 |
| 4.3 Checking the gas feeding pressure | page 4 |
| 5 - CHECK OF SOME MALFUNCTIONS | page 4 |
| 5.1 The pilot burner shows a difficult ignition or it fails to ignite | page 4 |
| 5.2 Extinction of pilot burner during the operation | page 4 |
| 5.3 The main burners show a difficult ignition or they fail to ignite | page 4 |
| 6 - REPLACING SOME COMPONENTS | page 4 |
| Main burners - Pilot burner - Thermocouple - Ignition plug of pilot burner Gas cock - Piezoelectric lighter | |
| 7- USE AND MAINTENANCE | page 5 |
| 7.1 Warning | page 5 |
| 7.2 Use of the griddle plate | page 5 |
| 7.3 Lighting the main burners of the cook top | page 5 |
| 7.4 Extinction of burners of the cook top | page 5 |
| 8 - CLEANING AND MAINTENANCE | page 5 |
| 9 - LIST OF SPARE PARTS | page 5 |
| 10 - ENCLOSURES | pages 6-11 |

WARNING

- DO NOT STORE FLAMMABLE MATERIALS IN OR NEAR THIS APPLIANCE

- DO NOT SPRAY AEROSOLS IN THE VICINITY OF THIS APPLIANCE WHILE IT IS IN OPERATION

1 - INSTRUCTIONS FOR INSTALLATION

1.1 Identifying the models: Models Series 700

| | 1/2 M (400mm) | | 1 M (800mm) | |
|---|---------------|----------------|-------------|----------------|
| Smooth plate - TOP | 7FT/G400 | 41803153121.AU | 7FT/G800 | 41803153141.AU |
| Smooth plate with T/STAT TOP | 7FTT/G400 | 41803153122.AU | 7FTT/G800 | 41803153142.AU |
| Streaked plate - TOP | 7FT/G410 | 41803153221.AU | 7FT/G810 | 41803153241.AU |
| Streaked plate with T/STAT TOP | 7FTT/G410 | 41803153222.AU | 7FTT/G815 | 41803153742.AU |
| Chromed plate with T/STAT TOP | 7FTT/G405 | 41803153622.AU | 7FTT/G805 | 41803153642.AU |
| Chromed Streaked plate with T/STAT TOP | 7FTT/G415 | 41803153722.AU | 7FTT/G815 | 41803153742.AU |
| Smooth plate on base | 7FTV/G400 | 41803113121.AU | 7FTV/G800 | 41803113141.AU |
| Smooth plate with T/STAT on base | 7FTTV/G400 | 41803113122.AU | 7FTTV/G800 | 41803113142.AU |
| Streaked plate on base | 7FTV/G410 | 41803113221.AU | 7FTV/G810 | 41803113241.AU |
| Streaked plate with T/STAT TOP | | | 7FTT/G810 | 41803153242.AU |
| Streaked plate with T/STAT on base | 7FTTV/G410 | 41803113222.AU | 7FTTV/G810 | 41803113242.AU |
| Chromed plate with T/STAT on base | 7FTT/G405 | 41803113622.AU | 7FTTV/G805 | 41803113642.AU |
| Streaked plate with T/STAT on base | 7FTTV/G415 | 41803113722.AU | 7FTTV/G815 | 41803113742.AU |
| Half smooth & half streaked top | | | 7FT/G820 | 41803153441.AU |
| | | | 7FTT/G820 | 41803153442.AU |
| | | | 7FTT/G825 | 41803153942.AU |
| Half smooth & half streaked on base | | | 7FTTV/G820 | 41803113442.AU |
| Half smooth & half streaked with T/STAT on base | | | 7FTTV/G825 | 41803113942.AU |

1.2 Technical data

The technical data of these fry-tops are indicated in the **Tables T1-T2**.

2 - GENERAL INSTRUCTIONS

Read the instructions of this handbook carefully because they supply important information on installation, use and maintenance safety. Keep this handbook for any further reference of the various operators. The installation, transformation and maintenance of this equipment must exclusively be carried out by authorised installers or by licensed gasfitters complying with the AS 5601 (AG601) Gas Installation standards and any local authority requirements in force..

The Manufacturer declines any liability if these rules are not complied with.

N.B. - This equipment complies with the CEI standard 61-50 and AS4551.

2.1 Installation

- After unpacking, check that the equipment is intact. In case of any doubt, do not operate this apparatus and call immediately a professional engineer.
- Arrange the packing elements far from children, because they can be dangerous.
- The equipment must definitively be installed in the position it occupies in the kitchen, preferably under an exhausting hood for a proper recirculation of air.
- The equipment must be installed only in rooms with good ventilation in accordance with the installation standards (AS5601).
- **Any commercial equipment of the type** must be installed only in rooms with a good exhaust system, according to the technical rules in force.
- Refer to the data plate on the appliance for relevant technical information e.g gas type, consumption, test point pressure, etc.
- These ranges can be installed separately, or assembled with other equipment of our line.
- This range is not available in built-in version.
- The equipment must be positioned at least 10 cm far from any wall surrounding it. Install the appliance in a non-combustable area. Ensure areas are suitably insulated if required in accordance with the installation standard (AS5601)..

- The overall dimensions of the equipment are indicated in the following pages.

2.5 Assembling

The "top" models can be mounted (directly by the manufacturer, or by the installer) on neutral cabinet bases, or on ovens with size of 1 "module" (width of 80 cm). Moreover some bridge assemblies can be carried out with the apparatuses arranged side by side.

- Remove the protection film from the outer surfaces of the apparatus. Clean these surfaces from probable residual adhesive using a proper solvent.
- Level the apparatus turning the proper adjustable feet.
- In stand-alone version, the fry-top with width of 40 cm must be fixed to the floor with the proper flanges (fig. 2A).
- As regards the assembling of the stack extension (when necessary), refer to the point 2.2.
- As regards the assembling of the draft switch (when necessary), refer to the point 2.4.

2.6 Assembling the fry-top on a neutral base (Fig. 3)

- Assemble the top on the proper neutral base through the following operations:
- Remove knobs, control board and back of the top.
- Position the top on its base.
- Fasten these two elements with the four screws **V**, as shown in the fig. 3.
- Reassemble the control board and the back of the top.

2.7 Aligning the equipment (Fig. 2)

Operate as follows:

- Remove the knobs and the control board of the top.
- Arrange the apparatuses side by side and level at the same height.
- Fasten the apparatuses with the proper screws, as shown in the fig. 2.

2.9 Connecting to the gas supply Important!

- Clean the pipes to remove any dust, dirt or foreign matter which could block the supply.

- Do not use pipes of a diameter smaller than that for which the appliance is designed. Ensure installation is "pipesized" for the whole installation.

- After installation the pipework, connections and appliance(s) should be checked for gas leaks in accordance with standard operations. Use soapy water to check connections for leaks.

Warning: Do not use naked flame to check for gas leaks!

- Make certain the appliance is arranged for the type of gas to be used. Otherwise the appliance will have to be converted to the applicable gas type. If not certain contact local gas supplier for confirmation of gas type. Any conversion to be carried out must be undertaken by an authorised person in accordance with the supplied instructions.

- Use of Flexible Hoses: Where it is intended to connect the appliance to the gas supply using a flexible, it is important to use the correct type assembly for the application. Refer to AS5601 for hose connection requirements. The hose assembly must comply with AS/NZS1869 – Class B and be kept as short as possible. A chain must be fitted to restrict the appliance movement to no more than 80% of the hose length.

- The section of the gas supply line must be sufficient to ensure the gas flow necessary for full operation of all of the appliances connected to the piping. Ensure an isolation valve and union is fitted at the inlet piping of the appliance.

- For **Natural gas** appliances, the regulator supplied with the appliance must be fitted between the gas valve and the appliance inlet.

- The gas pressure regulator will ensure constant outlet pressure over varying inlet pressures. An appliance regulator is not required for L.P.G. appliances as the pressure must be regulated by the regulator at the cylinder(s).

- When the regulator is fitted, it must be adjusted to the correct pressure when the burners are operating.

Test point pressures are: 1.0kPa for Natural Gas
2.65kPa for L.P.G. (Propane)

rontal connection.- Check

- Make sure the appliance is suitable for the type of gas available, according to that given on the data plate.

- The supply pressure must be measured with the appliance operating, using a manometer (min 0.1kPa).

- Ensure gas is turned off.

- Remove control panel.

- Remove test point screw from the pressure test point and connect the manometer.

- Turn the gas on slowly, light the applicable burners and compare the value read on the manometer with that given on the data plate.

- If the manometer gives a pressure outside the range adjust the gas regulator supplying the appliance. If the pressure cannot be adjusted to the correct value check the installation to determine problem.

4 - STARTING

4.1 Checking the operation

Start the equipment according to the **instructions of use**, and check:

- the correct operation of pilot and main burners;
- that there are no leaks;
- the correct operation of room ventilation systems;
- the efficiency of the exhaust gas system; if necessary, refer to the paragraph 5 "**Check of some malfunctions**";

- whether the data of the rating plate of the equipment correspond to those of the gas pipe network.

Warning: during the operation, take extreme care in handling the hot areas of the outer surface.

4.2 Checking the thermal power

After installing the equipment and adapting it to another gas group or in any maintenance operation, check the thermal power.

- The thermal power rating is indicated in the table **T2**.

- The equipment operates at the power rating when its nozzles actually correspond to the type of gas supplied and to the operating pressure indicated in the table **T1**.

- As regards the control of feeding pressure, refer to the paragraph 4.3 "**Checking the gas feeding pressure**".

4.3 Checking the gas feeding pressure

- Necessary measuring instrument: pressure gage with minimum accuracy rating of 0.2 mBar.

- Remove the control board of the cook top.

- Remove the tight screw of the pipe tap **P** (see fig. 1) and connect the pipe of the pressure gage to this tap.

- Carry out the measurement while the equipment is operating.

- The measured value must be included within the limits indicated in the table **T2**; otherwise, stop the test and call the gas service company.

- Disconnect the pipe of the pressure gage and screw down the screw of the pipe tap tightly.

5 - CHECK OF SOME MALFUNCTIONS

5.1 The pilot burner shows a difficult ignition or it fails to ignite

- Piezoelectric lighter, ignition plug or pilot burner cable faulty

- Insufficient gas feeding pressure.

- Nozzle or pipe clogged.

- The gas cock is faulty.

5.2 Extinction of pilot burner during the operation

- The thermocouple is faulty, or it is not properly heated, or not correctly connected to the gas cock.

- Gas feeding pressure drop.

- The gas cock is faulty.

5.3 The main burners show a difficult ignition or they fail to ignite

- Insufficient gas feeding pressure.

- Nozzles clogged.

- The gas cock is faulty.

6 - REPLACING SOME COMPONENTS

N.B.: The sealed components must not be tampered with. After any operation, check that there are no leaks, if necessary.

Warning! Service work must only be carried out by Authorised Persons.

6.1 Main burners of the griddle plate

Remove the griddle plate.

Remove the baffles and the burner closing plate,

Remove the control board and replace the component.

6.2 Pilot burners of the griddle plate

Remove the griddle plate.

Remove the control board and replace the component.

6.3 Gas cock of the griddle plate

Remove the control board and replace the component.

6.4 Thermocouple, piezoelectric lighter, ignition plug of the griddle plate

Remove the control board and replace the component.

- Ventilate the rooms periodically.
- Check the equipment periodically (at least once a year); this check must be carried out by qualified professional personnel. Drawing up a maintenance contract is recommended.

7 - USE AND MAINTENANCE

7.1 Warning

This equipment has been designed for professional aims, therefore it must be operated exclusively by trained personnel.

It must exclusively be used to cook food; consequently any other use is improper.

Before using the griddle plate for the first time, remove the industrial protection grease washing it with water and alkaline detergent.

Every day, before using the fry-top, drain the oil receiver.

Its installation and possible transformation for other gas group must be carried out by authorized and qualified installers.

In case of troubles, turn off the gas cutoff cock installed before the equipment.

For any repair, call the authorized After-Sales Service and require only original spare parts.

Not complying with these instructions may seriously compromise the safety of this equipment; the manufacturer declines any liability in case these warnings are not complied with.



It is recommended the appliance be visually checked for problems each week and the appliance be serviced by an authorised service person at least every 12 months or as may be required. This is not covered by warranty.

9 - LIST OF SPARE PARTS

- Gas cock of the griddle plate
- Pilot burner
- Thermocouple
- Ignition plug of pilot burner
- Main burner
- Piezoelectric lighter

7.2 Use of the griddle plate

The knob controlling the cocks of the griddle plate is marked with the following symbols:

- z **off**
- **pilot burner on**
-  **maximum fire**
-  **minimum fire**

7.3 Lighting the burners of the griddle plate

- Press and turn the knob to the position □ , then light the pilot burner pressing the button of the lighter. After lighting, keep the knob pressed for approximately 20 seconds, then release it. In case of extinction of the pilot burner, repeat this operation.
- Turn the knob to the desired position chosen between

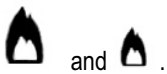

7.4 Extinction of burners

- Put off the main burner turning the knob to the position □ .
- Put off the pilot burner pressing and turning the knob to the position z .

8 - CLEANING AND MAINTENANCE

- Wash the surfaces of stainless steel with water and non abrasive detergents, every day; then rinse abundantly and wipe.
- When cleaning stainless steel, never use detergents with abrasive substances, chips, steel wool, brushes or scrapers of common steel.
- Clean the floor under the fry-top with non corrosive products.
- Do not wash the equipment with water jets.

When the equipment must not be used for long time, comply with the following instructions:

- Turn off the cutoff cock installed before the equipment.
- Clean all the surfaces carefully.
- Protect the surfaces of stainless steel laying off a light film of white mineral oil with a cloth.

T1

| | | | | |
|---|------------|----------------|------------|----------------|
| Smooth plate - TOP | 7FT/G400 | 41803153121.AU | 7FT/G800 | 41803153141.AU |
| Smooth plate with T/STAT TOP | 7FTT/G400 | 41803153122.AU | 7FTT/G800 | 41803153142.AU |
| Streaked plate - TOP | 7FT/G410 | 41803153221.AU | 7FT/G810 | 41803153241.AU |
| Streaked plate with T/STAT TOP | 7FTT/G410 | 41803153222.AU | 7FTT/G815 | 41803153742.AU |
| Chromed plate with T/STAT TOP | 7FTT/G405 | 41803153622.AU | 7FTT/G805 | 41803153642.AU |
| Chromed Streaked plate with T/STAT TOP | 7FTT/G415 | 41803153722.AU | 7FTT/G815 | 41803153742.AU |
| Smooth plate on base | 7FTV/G400 | 41803113121.AU | 7FTV/G800 | 41803113141.AU |
| Smooth plate with T/STAT on base | 7FTTV/G400 | 41803113122.AU | 7FTTV/G800 | 41803113142.AU |
| Streaked plate on base | 7FTV/G410 | 41803113221.AU | 7FTV/G810 | 41803113241.AU |
| Streaked plate with T/STAT TOP | | | 7FTT/G810 | 41803153242.AU |
| Streaked plate with T/STAT on base | 7FTTV/G410 | 41803113222.AU | 7FTTV/G810 | 41803113242.AU |
| Chromed plate with T/STAT on base | 7FTT/G405 | 41803113622.AU | 7FTTV/G805 | 41803113642.AU |
| Streaked plate with T/STAT on base | 7FTTV/G415 | 41803113722.AU | 7FTTV/G815 | 41803113742.AU |
| Half smooth & half streaked top | | | 7FT/G820 | 41803153441.AU |
| | | | 7FTT/G820 | 41803153442.AU |
| | | | 7FTT/G825 | 41803153942.AU |
| Half smooth & half streaked on base | | | 7FTTV/G820 | 41803113442.AU |
| Half smooth & half streaked with T/STAT on base | | | 7FTTV/G825 | 41803113942.AU |

| Gas | p kPa | Ugelli pilota o | 32 | 2x32 |
|---------|-------|---------------------|--------------|----------------|
| Nat Gas | 1 | Ugelli bruciatore p | 225 | 2x225 |
| | | Vite minimo n | 85Adjustable | 2x85Adjustable |
| | | A= mm r | 11 | 11 |
| | | Ugelli pilota o | 19 | 19 |
| L.P.G | 2,65 | Ugelli bruciatore p | 125 | 2 x 125 |
| | | Vite minimo n | 85 | 2x85 |
| | | A= mm r | 13 | 13 |
| | | Ugelli pilota o | 19 | 19 |

n Vite minimo - Kleinstellschraube - Minimum adjusting screw - Vis de reglage minimum - Schroef minimum stand

o Ugello pilota - Zündbrennerdüse - Pilot burner nozzle - Injecteur de la veilleuse - Gaspitten pilot

p Ugello bruciatore - Brennerdüse - Burner nozzle - Injecteur du bruleûr - Gaspitten brander

q Regolato - Geregelt - To adjust - Régle

r A= Regolazione aria primaria - Primärluftabstand - Primary air adjustment - Regulation de l'air - Regeling aanfangslucht

T2

| | | | | |
|---|------------|----------------|------------|----------------|
| Smooth plate - TOP | 7FT/G400 | 41803153121.AU | 7FT/G800 | 41803153141.AU |
| Smooth plate with T/STAT TOP | 7FTT/G400 | 41803153122.AU | 7FTT/G800 | 41803153142.AU |
| Streaked plate - TOP | 7FT/G410 | 41803153221.AU | 7FT/G810 | 41803153241.AU |
| Streaked plate with T/STAT TOP | 7FTT/G410 | 41803153222.AU | 7FTT/G815 | 41803153742.AU |
| Chromed plate with T/STAT TOP | 7FTT/G405 | 41803153622.AU | 7FTT/G805 | 41803153642.AU |
| Chromed Streaked plate with T/STAT TOP | 7FTT/G415 | 41803153722.AU | 7FTT/G815 | 41803153742.AU |
| Smooth plate on base | 7FTV/G400 | 41803113121.AU | 7FTV/G800 | 41803113141.AU |
| Smooth plate with T/STAT on base | 7FTTV/G400 | 41803113122.AU | 7FTTV/G800 | 41803113142.AU |
| Streaked plate on base | 7FTV/G410 | 41803113221.AU | 7FTV/G810 | 41803113241.AU |
| Streaked plate with T/STAT TOP | | | 7FTT/G810 | 41803153242.AU |
| Streaked plate with T/STAT on base | 7FTTV/G410 | 41803113222.AU | 7FTTV/G810 | 41803113242.AU |
| Chromed plate with T/STAT on base | 7FTT/G405 | 41803113622.AU | 7FTTV/G805 | 41803113642.AU |
| Streaked plate with T/STAT on base | 7FTTV/G415 | 41803113722.AU | 7FTTV/G815 | 41803113742.AU |
| Half smooth & half streaked top | | | 7FT/G820 | 41803153441.AU |
| | | | 7FTT/G820 | 41803153442.AU |
| | | | 7FTT/G825 | 41803153942.AU |
| Half smooth & half streaked on base | | | 7FTTV/G820 | 41803113442.AU |
| Half smooth & half streaked with T/STAT on base | | | 7FTTV/G825 | 41803113942.AU |

| Mj | min | max | min | max |
|--------------------------------|----------------------|------|----------------------|------|
| | 9,6 | 25 | 19,2 | 50 |
| Nat Gas 1kPa m ³ /h | | 0,69 | | 1,38 |
| Consumo gas** | | | | |
| L.P.G 2,65 kPa kg/h | | 0,51 | | 1,03 |
| Tipo - Bauart - Type | A₁ | | A₁ | |

** Consumo gas - Gasverbrauch - Gas consumption - Consommation du gaz - Gasverbruik

* Connessione gas - Gasanschluss - Arrivée gaz - Verbindung

Per installazione in Danimarca occorre avvitare sulla rampa d'alimentazione l'apposito nipplo.

Vor dem Anschluß an dieGasversorgungsanlage, ist es erforderlich, den als Ausstattung gelieferten passenden Nippel auf Versorgungsrampe gas einzuschrauben.

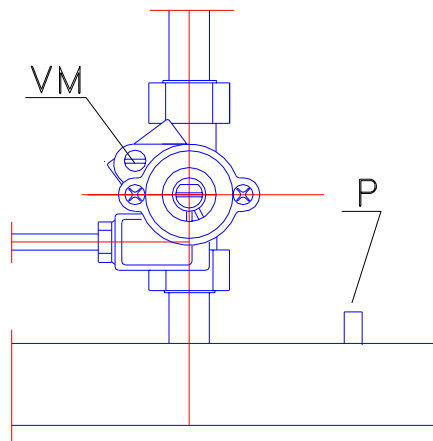

Fig.1 - Abb. 1

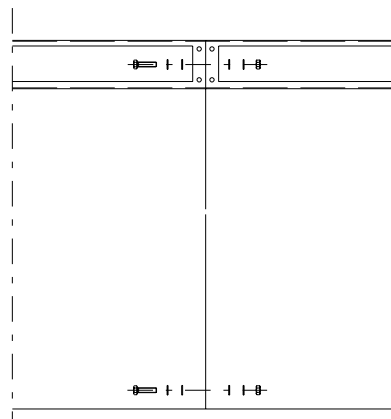
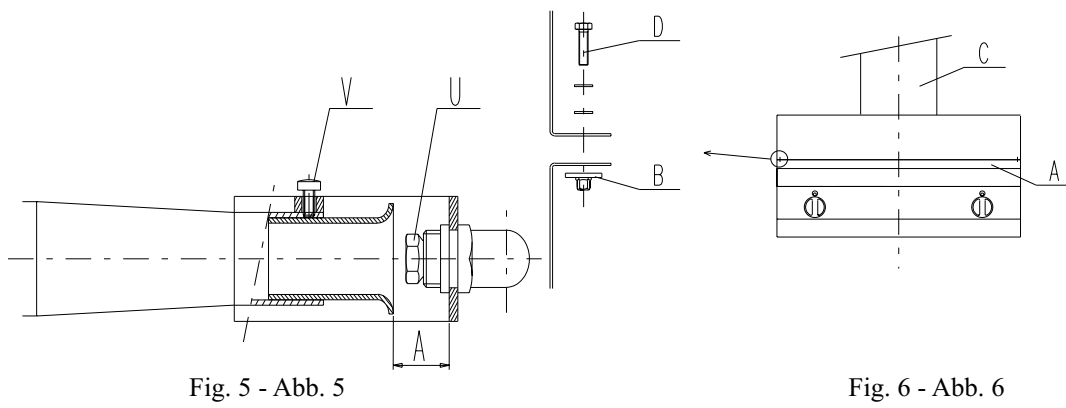
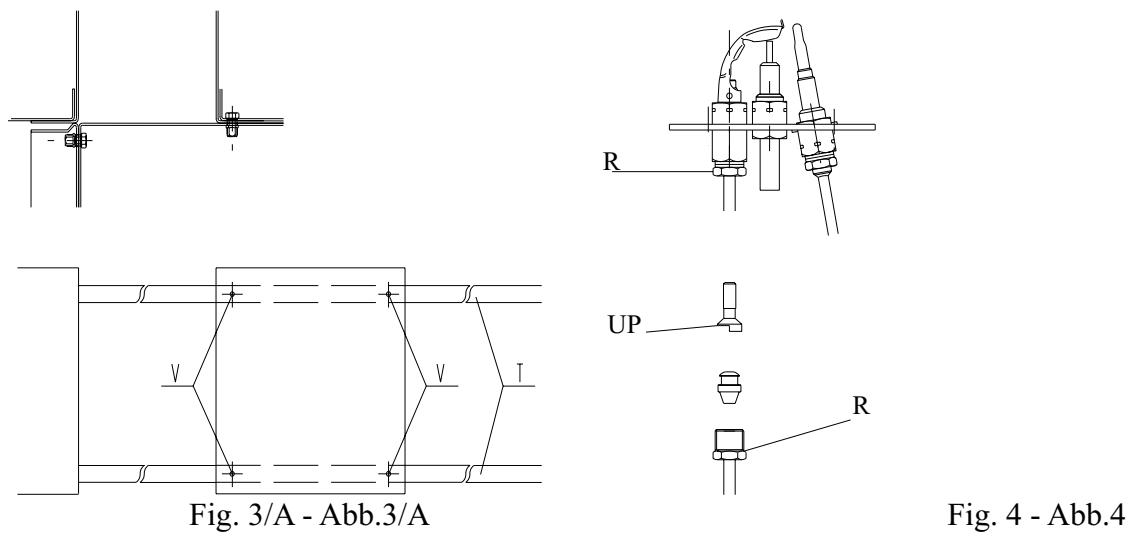
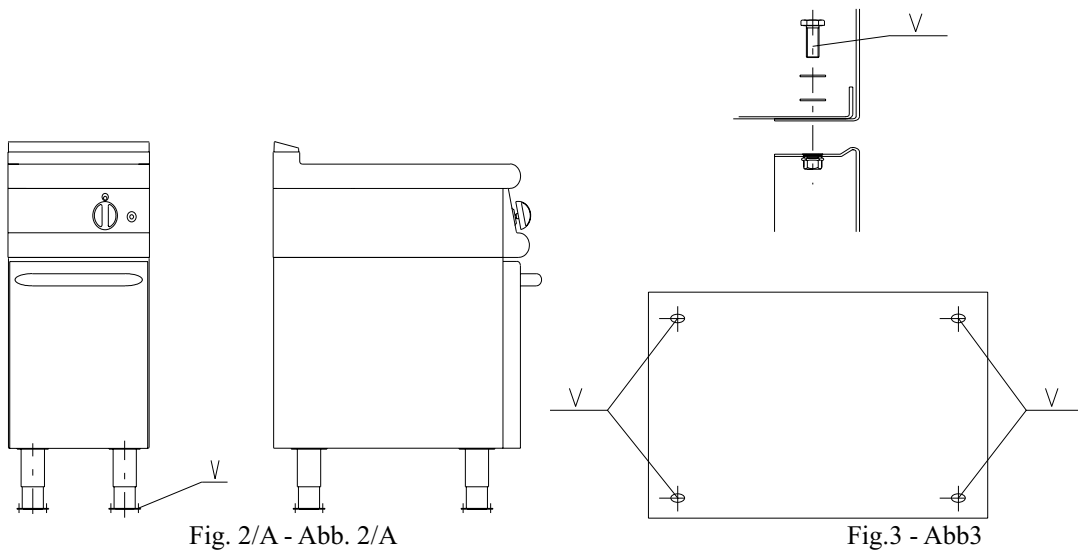

Fig.2 - Abb.2



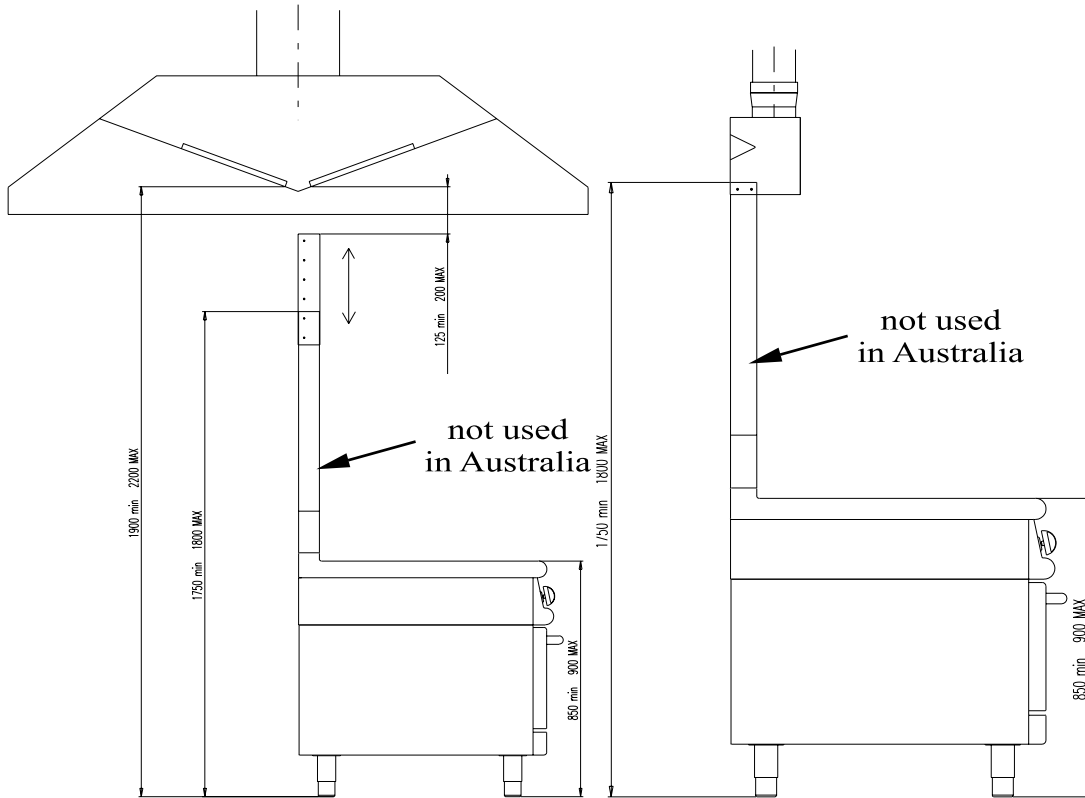
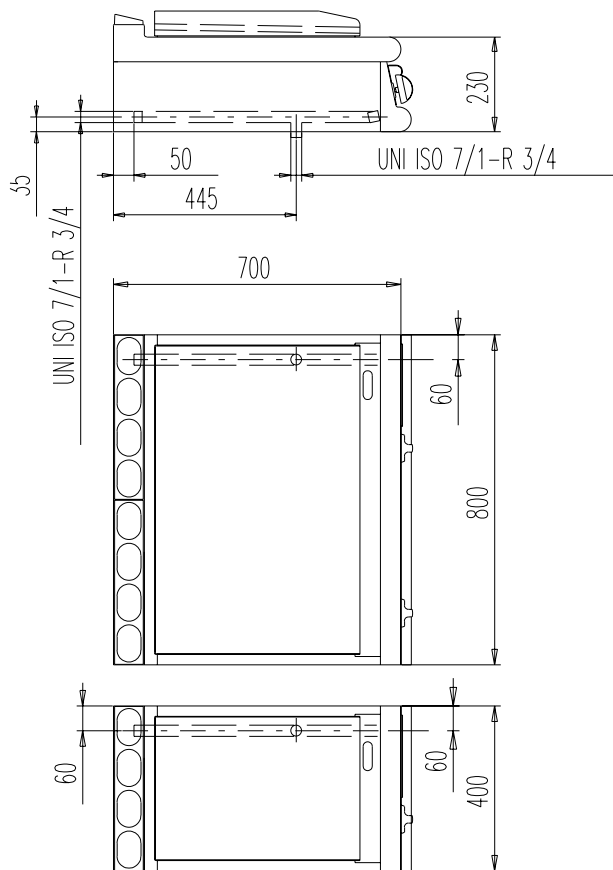

Fig.7 - Abb. 7
(für DE = B21 - siehe Punkt 2.3)

Fig. 8 - Abb 8
(für DE = B11 - siehe Punkt 2.4)



Serie 700

- 41803153141.AU
- 41803153142.AU
- 41803153241.AU
- 41803153242.AU
- 41803153441.AU
- 41803153442.AU
- 41803153642.AU
- 418031536421BAU
- 41803153742.AU
- 41803153942.AU

- 41803153121.AU
- 41803153122.AU
- 41803153221.AU
- 41803153222.AU
- 41803153622.AU
- 41803153722.AU

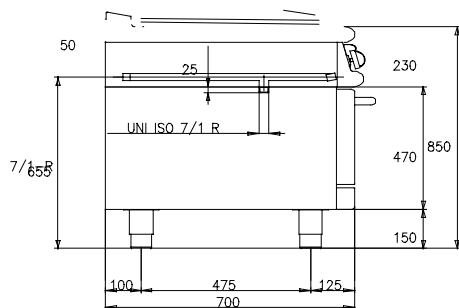

Mod.

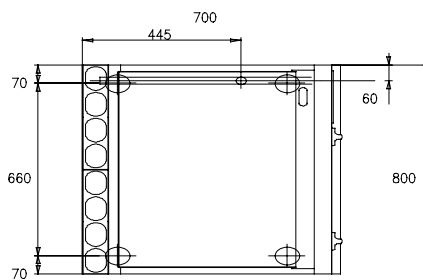

- 41803113141.AU
- 41803113142.AU
- 41803113241.AU
- 41803113242.AU
- 41803113441.AU
- 41803113442.AU
- 41803113642.AU
- 41803113742.AU
- 41803113942.AU

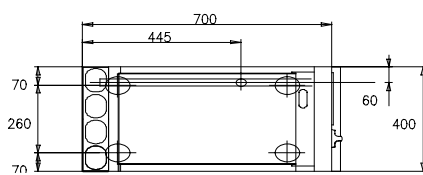

- 41803113121.AU
- 41803113122.AU
- 41803113221.AU
- 41803113222.AU
- 41803113622.AU
- 41803113722.AU