

ELECTRIC RANGES CERAMIC GLASS

700 Series

TYPE: 7NPC/VCE400, 7NPCV/VCE400, 7NPCVP/VCE400, 7NPC/VCE800,
7NPCV/VCE800, 7NPCVP/VCE800, 7NPCF/VCE800

User Manual



1. General information	1
1.1 Symbols used in the manual	1
1.2 Symbols used on the appliance	2
1.3 Checking correspondence between the appliance and the manual	2
2. Safety	3
2.1 Using the appliance safely	3
2.2 Safety instructions in the event of a fault	3
2.3 Disposing of the appliance	3
3. Functional description	5
3.1 Application of the appliance	5
3.1.1 Forbidden use	5
3.2 Cooking surface construction	5
3.3 Cooking tops	6
3.4 Electrical oven	6
3.5 Cooking top operating principle	6
3.5.1 Operating switches and indicator lights	7
4. Operating instructions	9
4.1 Before using the appliance	9
4.1.1 Preparing the appliance for use	9
4.2 Using the appliance	10
4.2.1 Switching on the cooking top	10
4.2.2 Cooking	11
4.2.3 Switching off	11
4.2.4 Switching on the electrical oven	12
4.3 After having used the appliance	13
4.3.1 Cleaning	13
4.3.2 Idle period	14
4.3.3 Periodic maintenance	14
4.3.4 Cleaning air filter	15

5. Installation	17
5.1 General information	17
5.1.1 Regulatory installation conditions	17
5.2 Exhausting fumes	17
5.3 Possible environmental interference	17
5.4 Storage	17
5.5 Unpacking the appliance	18
5.6 Disposal of packaging materials	18
5.7 Positioning	18
5.8 Electrical connections	19
5.8.1 General information	19
5.8.2 Connection requirements	19
5.8.3 Connecting the cable for Y-type electrical connection to the appliance terminal block models: 7NPCV/VCE 400, 7NPC/ VCE 400, 7NPCV/VCE 800, 7NPC/VCE 800	20
5.8.4 Connecting the cable for Y-type electrical connection to the appliance terminal block model 7NPCF/VCE 800	21
5.8.5 Equipotential terminal	23
5.9 Personnel training	24
5.10 Rating plate	24
6. Troubleshooting	25
7. Technical specifications	27

1. General information

Read the instructions in this manual carefully, as they contain important information on how to install, use and service the appliance safely, properly, and effectively.

Keep this manual in a safe place so that it can be used as reference by other operators of the appliance.

This appliance should be installed following the instructions provided by the manufacturer and in compliance with all applicable local regulations. Electricity and water connections to the appliance must be performed by qualified technicians.

The operators who will use the appliance have to be specifically trained beforehand.

In the event of failure or malfunction, switch off the appliance. The periodic functional checks requested in this manual have to be carried out according to the instructions. Have the appliance serviced by a technically qualified person duly authorized by the manufacturer that uses genuine spare parts.

Failure to comply with the above may jeopardise the appliance's safety.

1.1 Symbols used in the manual



This symbol informs us about a potentially hazardous situation. The instructions provided are mandatory in order to prevent injury.



This symbol informs us about the right way to act in order to prevent bad results, damage to the appliance, or hazardous situations.



This symbol informs about tips and hints that help the user to get the best performance from the appliance.



This symbol informs about a function that should be taken into account for self-control purposes.

1.2 Symbols used on the appliance



This symbol on a part warns the user that there are electrical terminals behind it. Therefore, the concerned part should only be removed by qualified personnel.

1.3 Checking correspondence between the appliance and the manual

The serial number for the appliance is given on the rating plate. If the manuals are missing, it is possible to order new ones from the manufacturer or your local representative. When ordering new manuals, it is essential to quote the serial number shown on the rating plate.

2. Safety

2.1 Using the appliance safely



Being an appliance designed for professional use only, it should be operated exclusively by qualified personnel.

Never leave the appliance unattended while in use!

Do not move the appliance while hot!

2.2 Safety instructions in the event of a fault

In the event of failure or malfunction, disconnect the appliance from the power supply. Call the technical support service.

If an emergency occurs, use the main switch to disconnect power to the appliance.

2.3 Disposing of the appliance

This appliance was built using recyclable raw materials and contains neither hazardous nor toxic substances. To dispose of the appliance, strictly follow all local regulations in force in the place where it is installed. Packaging materials have to be separated according to their types and delivered to the pertinent collection sites. Please abide by environmental protection regulations.



A crossed-out wheeled bin symbol means that the appliance, at the end of its useful life, has to be disposed of separately from other waste. At such time, therefore, bring this specific appliance to a collection point specialising in recycling electric and/or electronic equipment; or, bring it to the local representative when purchasing a similar type of appliance. Proper separate waste collection promotes recycling and contributes to preventing possible negative effects on both the environment and on human health. Users ridding themselves of the appliance in an unlawful manner are punishable by law.

3. Functional description

3.1 Application of the appliance

This appliance is designed for cooking goods using pans or saucepans that rest on the glass-ceramic cooktop.

3.1.1 Forbidden use

The appliance is not designed for cooking directly on the glass surface, as a fry-top would.

3.2 Cooking surface construction

Structure is made of stainless steel, standing on 4 height adjustable feet. Outside casing and top entirely made of stainless steel.

Unbreakable ceramic-glass top, with "watertight" fastening onto upper surface.

Indicator light signals heat remaining on the ceramic-glass top.

3.3 Cooking tops

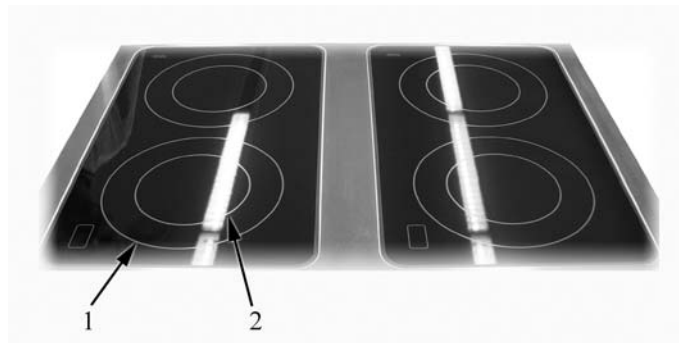

Fig. 1

1. Cooking zone, 230 mm diameter (1.4 kW)
2. Cooking zone, 150 mm diameter (1.1 kW)

- Each cooking zone is marked by silkscreened concentric circles, indicating the various heating levels;
- power adjustment from minimum to maximum (item 3 and item 4 in Fig. 3);

3.4 Electrical oven

- Static oven in stainless steel, with adjustable temperature control from 50° to 300°C (122°-572°F);
- two sets of heating elements (one on upper and one on lower side) adjustable separately through a selector and a sole thermostat;
- safety thermostat against any overtemperature;
- knobs fitted with watertight gasket;
- rack support structure featuring a non-tip device and 3 loading positions;
- removable stainless steel floor plate;

3.5 Cooking top operating principle

The heating elements underneath the glass-ceramic top heat the surface up to the desired temperature; a few minutes are sufficient for a 550° C temperature to be reached.

Heat is absorbed by the pan through direct contact and through radiation.

When cooking food, power saving depends on the quality of pans, and on their bottoms in particular.

The diameter of the pan has to match the diameter of the cooking zone. Use pans suitable for use on electric hot plates.

3.5.1 Operating switches and indicator lights

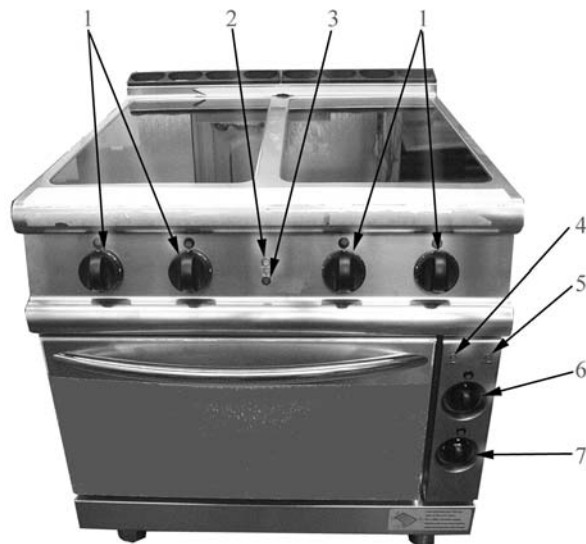

Fig. 2

1. Cooking zone temperature adjustment knob
2. Line lamp
3. Safety trip indicator lamp
4. Oven on light (model with oven)
5. Oven line lamp (model with oven)
6. Oven heating direction knob (model with oven)
7. Oven thermostat knob (model with oven)

4. Operating instructions

4.1 Before using the appliance



If the glass is broken, do not use the appliance: danger of electrical shock!

4.1.1 Preparing the appliance for use

Remove all packaging materials and adhesive films very carefully. Remove the protective film from the panels, ensuring no traces of glue are left on the steel surface; if necessary, use a non-flammable solvent to remove the glue.

Before cooking food for the first time, we recommend cleaning the appliance thoroughly, especially the ceramic-glass top, using hot water and a sponge.

To clean the stainless steel parts, ensure the detergent is non-abrasive and suitable for use with stainless steel.

After cleaning the appliance, rinse it well with clean water and wipe it dry with a clean cloth.



Never use a water jet to clean the appliance!

4.2 Using the appliance

4.2.1 Switching on the cooking top

Turning the knob to the desired position switches on the power indicator light (item 2 in Fig. 2). This means that the appliance is on and the selected cooking zone is beginning to heat up. This type of heating takes place when the heating elements are enabled and heat spreads through radiation. The heating elements temperature can be adjusted through a power regulator.

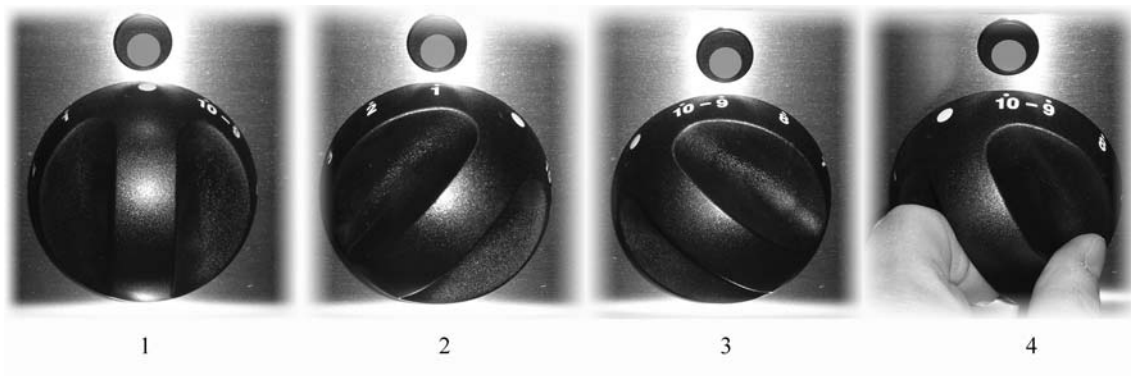

Fig. 3

1. OFF position
2. Minimum temperature
3. Maximum temperature
4. Switching on the second heating element

By turning the knob further, for a few seconds, until it reaches (pos. 4 in Fig. 3), the selected zone reaches maximum heat thanks to the second heating element switching on.



To bring the appliance back to its normal operating status -with only one heating element switched on-, turn the knob to the 0 position; if additional heat is needed, select the desired temperature.

Operating instructions

4.2.2 Cooking

1. Select the cooking temperature using the power adjustment knob.
2. When cooking food, power saving depends on the quality of pans, and on their bottoms in particular.
3. The diameter of the pan has to match the diameter of the cooking zone. Use pans suitable for use on electric hot plates.
4. Always use a pan lid during cooking time.
5. Use maximum level to reach cooking temperature, then lower it sufficiently enough to continue cooking.



Never leave the appliance unattended while in use!



In daily use, only use perfectly dry pans. Do not rest damp containers or objects with steam, such as pan lids, on the ceramic-glass top.

4.2.3 Switching off

Switch the appliance off by turning the power adjuster knob to the 0 position. The green indicator light will also dim.



Cooking top could still be burning hot! The appliance is nonetheless equipped with an additional indicator that shows any heat left on each cooking zone.

Operating instructions

4.2.4 Switching on the electrical oven

Choose the heating direction on the knob indicated as (item 3 in Fig. 4). Set the cooking chamber temperature by turning the oven operating thermostat knob in clockwise direction (from item 4b to item 4c in Fig. 4), the heating elements start to operate and the line pilot lamps (item 2 e item 5 in Fig. 2) light up together with the oven indicator lamp (pos. 4 in Fig. 2). When the selected temperature has been reached, the indicator lamp turns off. The oven temperature can be set between 50° and 300°C and to intermediate values.



A bad smell during the first ignition is considered within the norm and it is due to the overheating of the oil residues used for the metal processing and to insulating materials. During the first ignition, without putting food into the chamber, set the oven to a temperature of 300°C until the smell disappear.

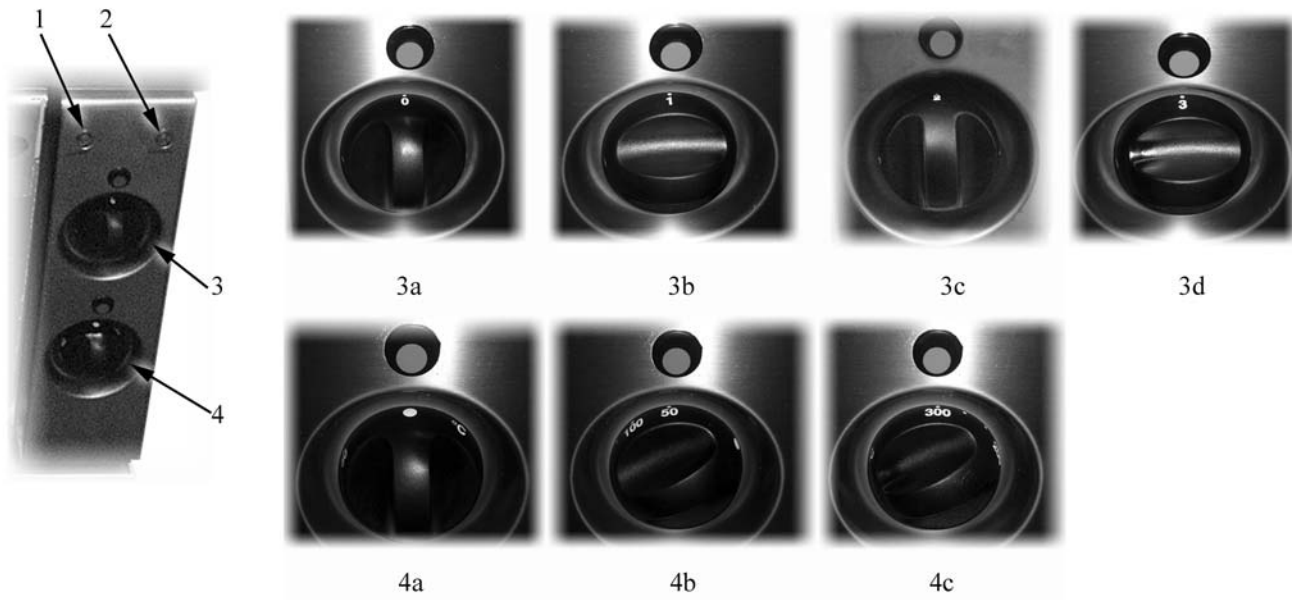

Fig. 4

1. Electrical oven indicator lamp
2. Line pilot lamp
3. Heating direction knob
4. Electrical oven thermostat knob
- 3a. OFF heating position
- 3d. Heating direction of the top heating element
- 3c. Heating direction of the bottom heating element
- 3b. Heating direction of both heating elements (top and bottom)
- 4a. OFF position
- 4b. 50°C position (minimum temperature)
- 4c. 300°C position (maximum temperature)

4.3 After having used the appliance

4.3.1 Cleaning



Before cleaning, switch the appliance off and disconnect its power supply.

General information

The main causes for stainless steel wear or corrosion are:

- using abrasive or acid detergents especially chlorine-based products, such as hydrochloric acid or sodium hypochlorite (bleach). Therefore, before buying a cleaning product, make sure it does not corrode stainless steel (also see paragraph "Routine cleaning" below);
- ferrous deposits (such as rust dissolved in the water through the pipe system, especially after a long time without being used), therefore have to be avoided; do not use wire wool to remove stubborn food deposits. Use, instead, pads or spatulas made of stainless steel or softer, non-ferrous materials;
- Do not use abrasive steel wool pads to clean the ceramic-glass top; it could get scratched.
- stagnation of substances having acid components such as vinegar, lemon juice, sauces, salt, etc. Avoid prolonged contact of the stainless steel parts of the appliance with those substances. The evaporation of saline solutions over the appliance surfaces is particularly harmful to them.



Routine cleaning

Cleaning the appliance thoroughly on a daily basis is the key to keeping it in perfect working condition and to prolong its life. Clean the appliance with a damp cloth using water and soap or detergents, provided that they are not acid or abrasive as discussed above. Such detergents should not even be used to wash the floor near the appliance, as their fumes may deposit on the steel surfaces and damage them. If the appliance is very dirty, use a Scotch-Brite™ type synthetic sponge. Rinse it well with clean water and wipe it dry with a clean cloth. Do not rub the appliance with steel wool pads as they could leave rust stains. For the same reason, avoid touching the appliance with ferrous objects.



Never use direct water jets to clean the appliance because this could result in water entering into it and damaging it.



Do not use abrasive steel wool pads to clean the ceramic-glass top; it could get scratched.

Stains and abrasions on the steel surface

Scratches and dark stains may be smoothed or removed using stainless steel wool pads or synthetic abrasive sponges, which should always be rubbed in the same direction as the satin finish.

Rust

If you need to remove rust stains, contact manufacturers of industrial detergents to find a suitable product. Industrial descaling products can also be used to that end. After removing stains and rinsing off the appliance with clean water, an alkaline detergent may be required to neutralize any acid compounds left on the surface.

Cleaning the ceramic-glass top

Some suggestions to be most satisfied from using the appliance:

- remove, first of all, any dirt and food residue using a fitting **NON-ABRASIVE** scraper;
- when the top is cold, pour a few drops of suitable detergent; rub using some paper towel or a soft cloth;
- rinse the top and dry it with a clean cloth or paper towel;



Clean the top frequently, every time it is used.



Remove immediately any melted aluminum foil, plastic wrapping, sugar or foods with a high sugar content while cooking zone is still hot. Use a non-abrasive scraper. This will prevent possible damages to the cooking top surface.



When cooking foods having a high dosage of sugar (i.e. jam), apply a fitting protective coating on the cooking surface to prevent damages in case of spills from the pan.

4.3.2 Idle period

If the appliance will be idle for some time, clean it and wipe it dry first, and then apply a film of a suitable product (such as vaseline oil spray or similar) to protect it. Switch the power off fitted upstream from the appliance.



In order to prevent corrosion spots from forming, ensure that any salt residues are carefully removed from the sides, internally and externally.

4.3.3 Periodic maintenance

Only qualified personnel are allowed to carry out service and maintenance operations.

The following maintenance operations have be carried out at least once a year:

- checking that all control and safety devices operate correctly;



We recommend signing a service agreement providing for at least one check-up a year.

4.3.4 Cleaning air filter

The following cleaning operations have to be done on a weekly basis:

- Pull downward the filter fixing frame (item 2 of Fig. 4a);

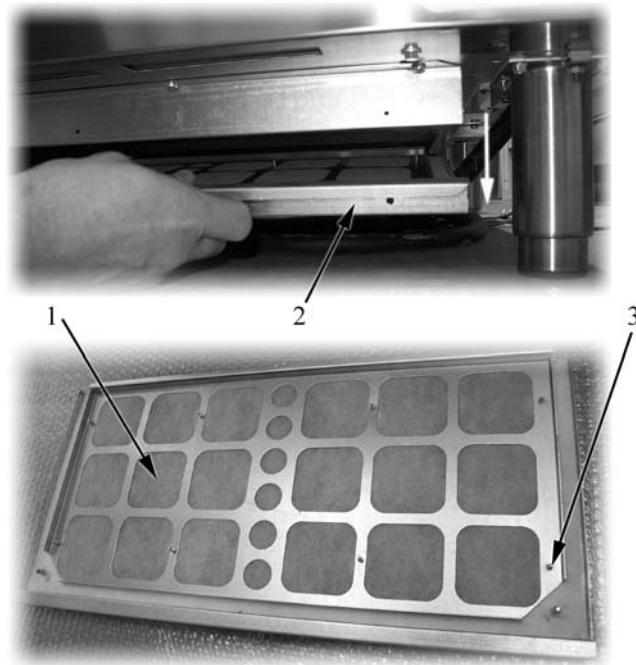

Fig. 4a

1. Filter
2. Filter fixing frame
3. Filter fixing screws

- Take out the filter fixing frame;
- Clean the filter using compressed air and replace the frame in its housing.



When the filter is very dirty, replace it by unscrewing the fixing screws (item 3 of Fig. 4a).

5. Installation

5.1 General information



The manufacturer cannot be held liable for any injuries to persons or damage to property resulting from installation errors or from inappropriate use of the appliance and is not responsible for any faults caused by defective installation. In such cases, the warranty shall be null and void.

Installation, maintenance, connection to power supply, and start-up have all to be performed by an authorised installer who must ensure compliance with all applicable safety regulations in force in the location where the appliance is being installed.



Check that the appliance is pre-set to operate on the voltage available at the place of use. Should the available voltage rating be different, do not install the appliance.

5.1.1 Regulatory installation conditions

We remind you that all appliances installed in public assembly buildings must meet the requirements specified below. The appliance has to be both installed and serviced in compliance with all applicable rules and legal regulations in force, namely:

- safety regulations on fire hazard and panic in public assembly buildings;
- general regulations applicable to all appliances;

5.2 Exhausting fumes

The appliance should be installed in a well-ventilated area, if possible under an exhaust hood, in compliance with all applicable regulations in force, in order to ensure that steam and cooking fumes are effectively exhausted.

5.3 Possible environmental interference



If the appliance is installed in the immediate vicinity of other electric units, ensure that they do not interfere with each other. They should all have independent power supplies.

5.4 Storage

If the appliance is stored in a warehouse where room temperature is below 0° (32°F), it should be warmed up to at least +10° (50°F) before switching it on.

5.5 Unpacking the appliance

Remove all packaging materials before installing the appliance. Some parts are wrapped in adhesive film, which have to be thoroughly removed (see paragraph "4.1.1 Preparing the appliance for use").

5.6 Disposal of packaging materials

All packaging materials have to be disposed of in compliance with the local regulations in force where the appliance is installed. Packaging materials have to be separated according to their types and delivered to the pertinent collection sites. Please abide by environmental protection regulations.

5.7 Positioning



Switch the power off before performing any type of repair on the appliance.

Level the appliance using a bubble level. The height can be regulated by turning the adjustable feet. This way, the appliance remains firmly in place.

Ensure that all the fire-prevention and safety regulations for the workplace are observed.

If the appliance is installed with its sides next to flammable walls (made of wood or similar materials) or to heat-sensitive walls (made of plasterboard or similar materials), suitable protective measures have to be taken to keep such walls undamaged. Either apply a coating over the wall to insulate it from irradiative heat or keep a minimum clearance of 300 mm from the sides and 250 mm from the rear of the appliance.



If the appliance is installed in proximity of a wall, the vertical opening created on the rear of the appliance has to clear of obstacles in the downward direction.



The holes on the rear have to be left clear.

5.8 Electrical connections

5.8.1 General information



The appliance must always be connected to an earthing (grounding) system while in operation.

The appliance is pre-set to be connected to the electrical control board. Before connecting the appliance to the power supply network, check:

- that distribution network voltage matches the voltage shown on the appliance's rating plate;
- that the grounding (earthing) system is effective;
- that the power lead is made of rubber and is of at least the same quality as cable type H07RN-F, with conductors having a cross section suited to the maximum load they will carry (refer to "*Technical specifications table*" at the end of this manual);
- that an effective multi-pole breaker having a contact gap of at least 3 mm should be fitted upstream from the appliance when it is installed. Automatic thermal-magnetic circuit breakers may be used for this purpose. The multi-pole breaker should be installed in the immediate vicinity of the appliance and be readily accessible. We recommend fitting a thermal-magnetic circuit breaker with built-in fuse protection;
- the power lead of the appliance should not be exposed to direct heat.

5.8.2 Connection requirements



IMPORTANT: The mains supply line that the appliance is to be connected to must comply with the following specifications :

Maximum resistance phase conductors : $R_{A \max} = 0,208 \Omega$.

Inductive reactance of phase conductors : $X_{A \max} = J 0,13 \Omega$ at 50 Hz.

Maximum resistance of neutral wire : $R_{N \max} = 0,139 \Omega$.

Inductive reactance neutral wire : $X_{N \max} = J 0,087 \Omega$ at 50 Hz.

5.8.3 Connecting the cable for Y-type electrical connection to the appliance terminal block models: 7NPCV/VCE 400, 7NPC/ VCE 400, 7NPCV/VCE 800, 7NPC/VCE 800



Only the manufacturer's service centre or similarly trained individual may replace the power cable.

To access the power terminal block, proceed as follows:

- Disconnect the power supply;
- Remove the knobs (item 2 in Fig. 5);
- Loosen the fixing screws to remove the control panel (item 1 in Fig. 5).

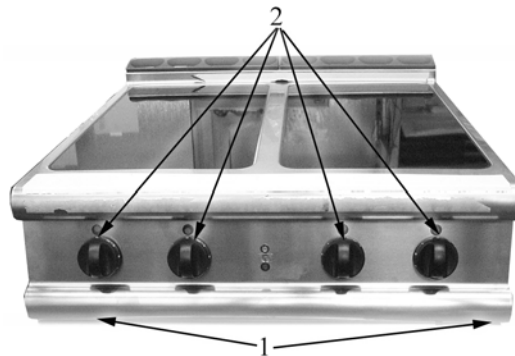

Fig. 5

1. Fixing screws
2. Knobs

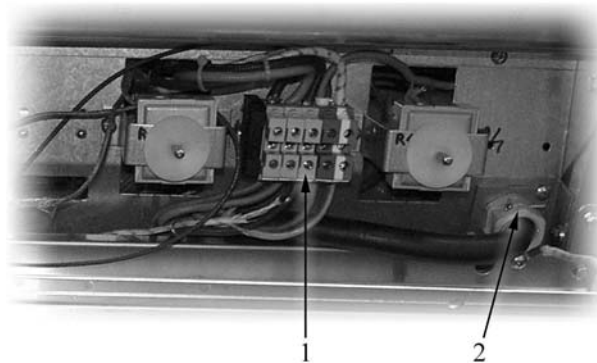

Fig. 6

1. Terminal block
2. Cable clamp

The power cable must be secured with the cable clamp fitted to the appliance (item 2 in Fig. 6) to prevent it from being damaged.



The length of the ground (earth) cable should be such as to allow it to support any possible mechanical stress **after** the live leads.

5.8.4 Connecting the cable for Y-type electrical connection to the appliance terminal block model 7NPCF/VCE 800



Only the manufacturer's service centre or similarly trained individual may replace the power cable.

To access the power terminal block, proceed as follows:

- Disconnect the power supply;
- Remove the angle bar (pos. 2 in Fig.7) loosening the fixing screws (pos. 1 in Fig.7);
- Remove the lower front panel (pos. 4 in Fig. 7), loosening the fixing screws (pos. 3 in Fig. 7).

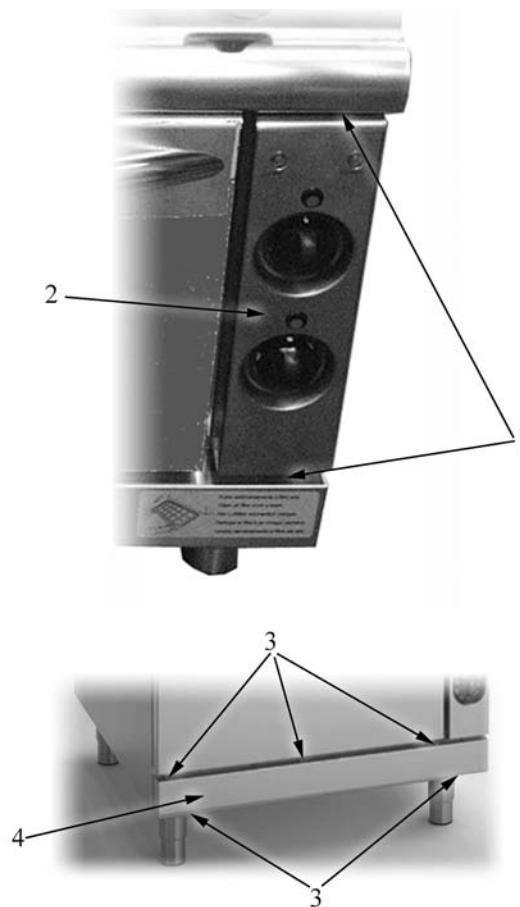

Fig. 7

1. Angle bar bolts
2. Angle bar
3. Front panel fixing screws
4. Lower front panel

**Fig. 8**

1. Terminal block
2. Cable clamp
3. Side panel fixing screws
4. Side panel

The power cable must be secured with the cable clamp fitted to the appliance (item 2 in Fig. 8) to prevent it from being damaged.

If this proves difficult, loosen the lower and rear fixing screws (pos. 3 in Fig.8) to take the right side panel off the appliance too (pos. 4 in Fig. 8).

5.8.5 Equipotential terminal



The appliance must be connected to an equipotential system. A connecting terminal has been provided on the lower right of the appliance for this purpose.

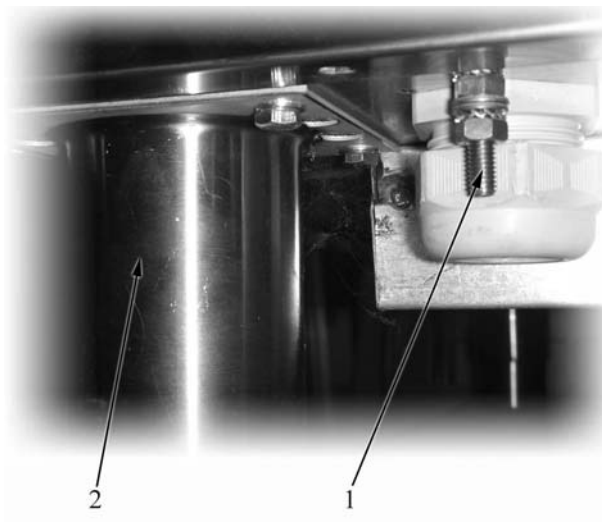

Fig. 9

1. Equipotential terminal
2. Right front foot

5.9 Personnel training

Inform the operators who will use the appliance about its functions, referring to the instruction manual and give them a copy of the manual.

5.10 Rating plate

The rating plate showing the specifications of the corresponding model is applied in the position shown in the installation and connection drawings and includes the data listed below:

Manufacturer:	
Model:	(see front page)
Serial number:	
Year of manufacture:	
Category:	(see "Technical specifications table")
Heating power:	(see "Technical specifications table")
Natural gas consumption:	(see "Technical specifications table")
Liquid gas consumption:	(see "Technical specifications table")
Supply pressure:	
natural gases: G20	(see "Table of gas categories and pressure values" above)
liquid gases (butane/propane): G30/ G31	(see "Table of gas categories and pressure values" above)
town gas: G110/G120	(see "Table of gas categories and pressure values" above)
Gas supply:	(see "Technical specifications table")
Supply voltage:	(see the label on the packaging and on the appliance)
Appliance adjusted to use:	

6. Troubleshooting

If the appliance fails to work, first of all check for blown fuses (overload protection) in the fuse box. Have the overload protection device checked by a qualified technician.



The operator is not to do maintenance work on any parts of this appliance. Maintenance has to be carried out by an authorized technician.

TROUBLE	POSSIBLE CAUSES	WHAT TO DO	
		FOR THE USER	FOR THE AUTHORIZED INSTALLER
COOKING TOP			
Heating element does not heat up:	No power;	Check that the appliance is energized;	
	Heating element break;		Replace it (see the chapter on Replacing the heating element of the cooking top);
	Faulty power regulator;		Replace it (see the chapter on Replacing the power regulator);
Heating element temperature of the cooking top cannot be adjusted:	Faulty power regulator;		Replace it (see the chapter on Replacing the power regulator);
ELECTRIC OVEN			
No heating:	No power;	Check that the appliance is energized;	
A temperature is set but the oven won't light:	Safety thermostat has tripped;		Reset the thermostat;
Oven temperature can't be adjusted:	Faulty operating thermostat;		Replace it (see the chapter on Replacing the operating thermostat);

Troubleshooting

Uneven cooking (pronounced difference in the product colouring):	Improper selector position or position not suitable to the type of cooking	Place the selector so that heat is generated by both the bottom and the top of the oven according to the type of cooking to be performed;	
	different product size or thickness;	in order to obtain an even cooking, the product has to be distributed uniformly on each pan. In case of solid food, the size, the layers and the thickness must be as uniform as possible;	
	non-horizontal racks;	level the appliance and check that the racks are horizontal using the adjustable feet: this operation is fundamental for an even cooking;	
	one of the two heating elements is faulty;		Replace it (see the chapter on Replacing the heating element).
COOKING TOP AND ELECTRIC OVEN			
The appliance stops functioning and the red emergency light indicator lights up;	Air suction filter is blocked;	Clean the filter (see relevant chapter);	
	Faulty cooling fan(s);	If the filter is clean, call the technical support service;	Check the fans efficiency and replace if faulty (see the related chapter);
	Faulty auxiliary components in the electric circuit;		Check efficiency of thermostats that enable fans;
	Blocked air outlet holes due to incorrect appliance installation;		Check that the appliance installation complies with instructions provided in the chapter on Installation;
Power indicator light switches on but the zone activated through the knob does not heat up:	Faulty auxiliary components in the electric circuit;		Check the operating status of both the electric circuit and the over-temperature safety contactor which isolates the heating elements power line.

7. Technical specifications

Connection diagrams28

Installation and connection drawings.34

Technical specifications table39

Technical specifications

827LE0012: legend of the wiring diagram 827SC0012 key			
7NPCF/VCE 800 - 3/N/PE~400V 50-60 Hz			
Abbrev	Codes	Descriptions	Characteristics
B2	826630123	Control thermostat	50 - 300°C - 3F
B16	826630130	Safety thermostat	360°C - 3F
B1-3-5-7-9	6A035200	Control thermostat	110°C - 1F
B4-6-8	6A035210	Control thermostat	150°C - 1F
E1-E2	826650050	Line lamp	230V - 120°C
E6	A038506	Safety trip indicator lamp	230V - 120°C
E16	A038506	On lamp	230V - 120°C
E26-27-28-29	6A001404	Still warm lamp	230V
E51-52-53-54	6A001401	Heating element	1100W + 1400W - 230V
E56-E57-E58-E59	826620041	Heating element	1500W - 230V
M1-2	6A036420	Cooling fan	230V - 1F - 16W
Q1	6A047036	Safety contactor	230V - 32A
R1-2-3-4	6A001402	Energy regulator	230V - 13A
S6	6A046001	Switch	3F
S7	6A046750	Switch	4 POS.
Q2	6A047031	Contactor	230V - 20A
V1	826630270	Mains filter	500Vac

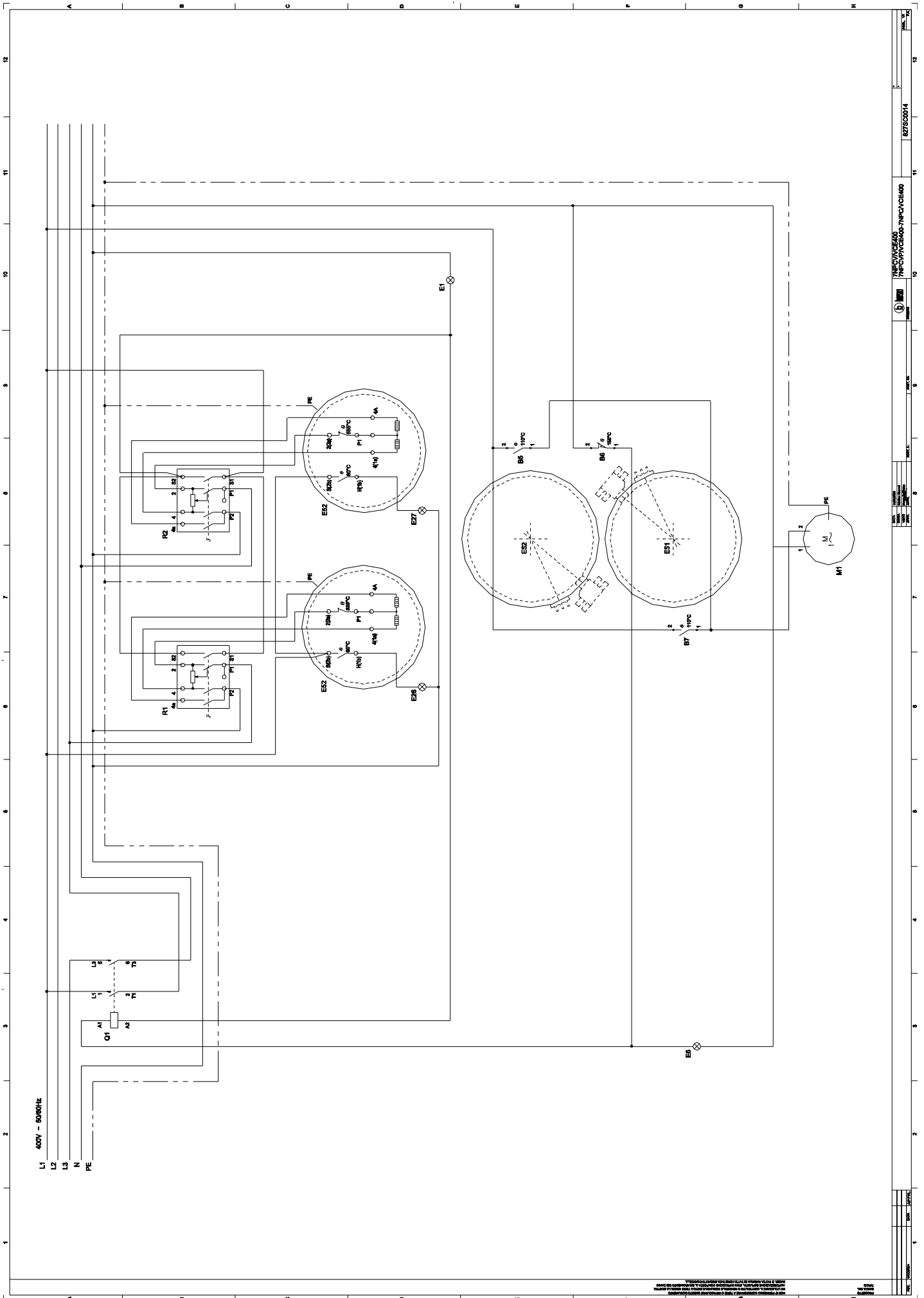

827SC0014: Wiring diagram 7NPC/VCE400-7NPCV/VCE400-7NPCVP/VCE400 3/N/PE 400V ~ 50/60 Hz

Technical specifications

827LE0014: legend of the wiring diagram 827SC0014			
7NPC/VCE400-7NPCV/VCE400-7NPCVP/VCE400 - 3/N/PE~400V 50-60 Hz			
Abbrev	Codes	Descriptions	Characteristics
B5-7	6A035200	Control thermostat	110°C -1F
B6	6A035210	Control thermostat	150°C -1F
E1	826650050	Line lamp	230V - 120°C
E6	826650060	Safety trip indicator lamp	230V - 120°C
E26-27	6A001404	Still warm lamp	230V
E51-52	6A001401	Heating element	1100W + 1400W - 230V
M1	6A036420	Cooling fan	230V - 1F - 16W
Q1	6A047036	Safety contactor	230V - 32A
R1-2	6A001402	Energy regulator	230V - 13A

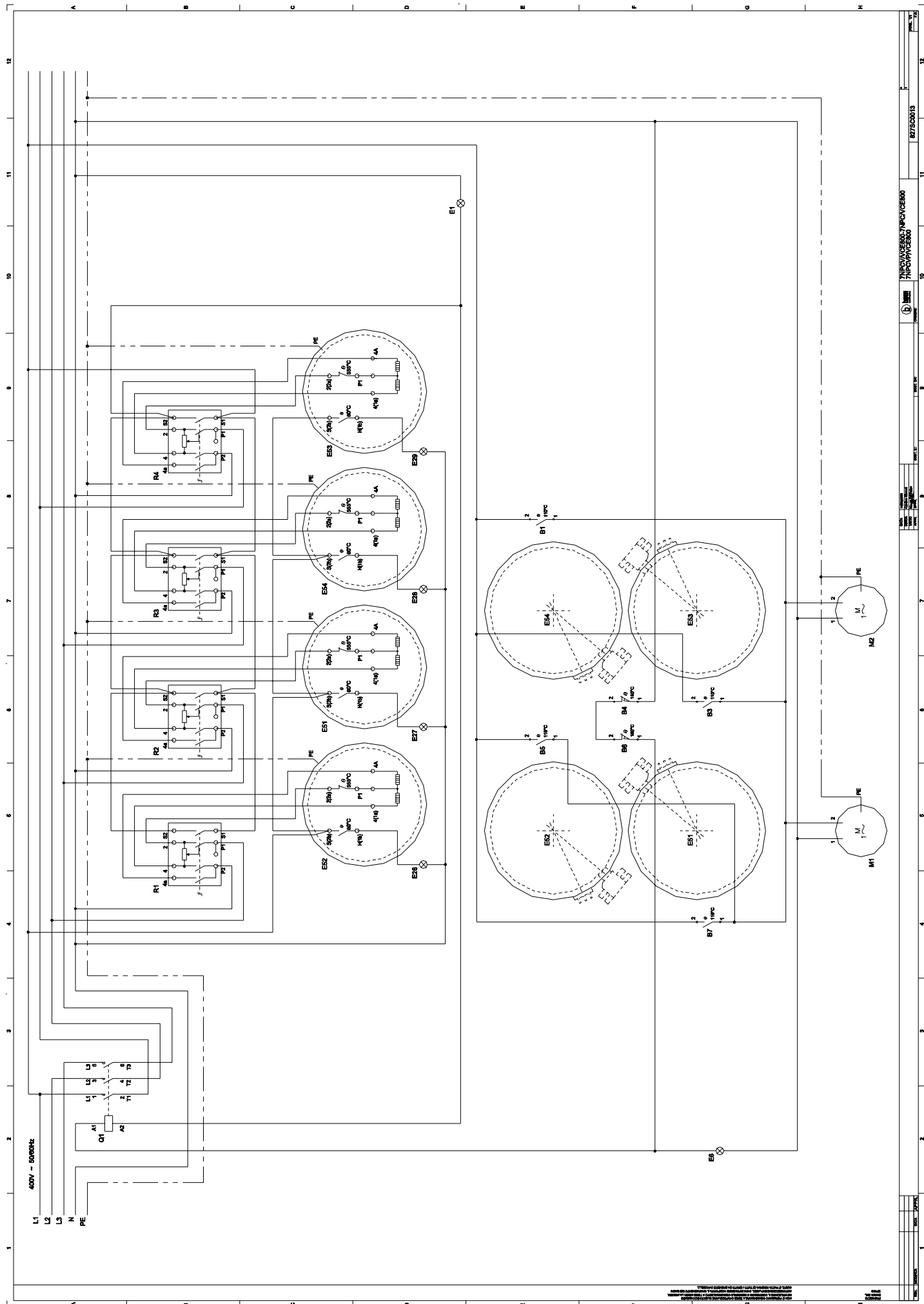

827SC0013: Wiring diagram 7NPC/VCE800-7NPCV/VCE800-7NPCVP/VCE800 3/N/PE 400V ~ 50/60 Hz

Technical specifications

827LE0013: legend of the wiring diagram 827SC0013			
7NPC/VCE800-7NPCV/VCE800-7NPCVP/VCE800 - 3/N/PE~400V 50-60 Hz			
Abbrev	Codes	Descriptions	Characteristics
B1-3-5-7	6A035200	Control thermostat	110°C -1F
B4-6	6A035210	Control thermostat	150°C -1F
E1	826650050	Line lamp	230V - 120°C
E6	826650060	Safety trip indicator lamp	230V - 120°C
E26-27-28-29	6A001404	Still warm lamp	230V
E51-52-53-54	6A001401	Heating element	1100W + 1400W - 230V
M1-2	6A036420	Cooling fan	230V - 1F - 16W
Q1	6A047036	Safety contactor	230V - 32A
R1-2-3-4	6A001402	Energy regulator	230V - 13A

Technical specifications

Installation drawing 7NPCV/VCE400, 7NPCVP/VCE400

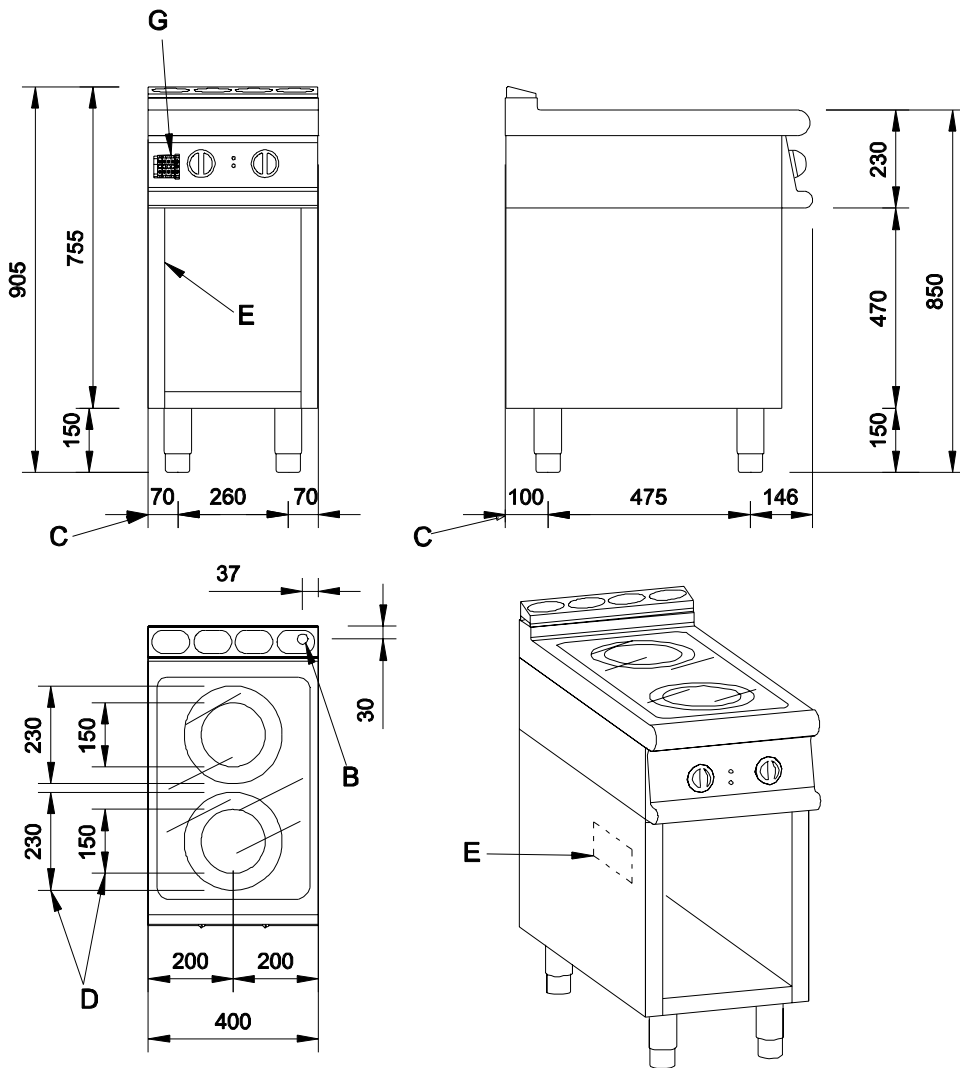

B	Fitting electric connection cable
C	Distance between feet
D	Cooking zone diameter
E	Plate
G	Terminal block

Technical specifications

Installation drawing 7NPCV/VCE800, 7NPCVP/VCE800

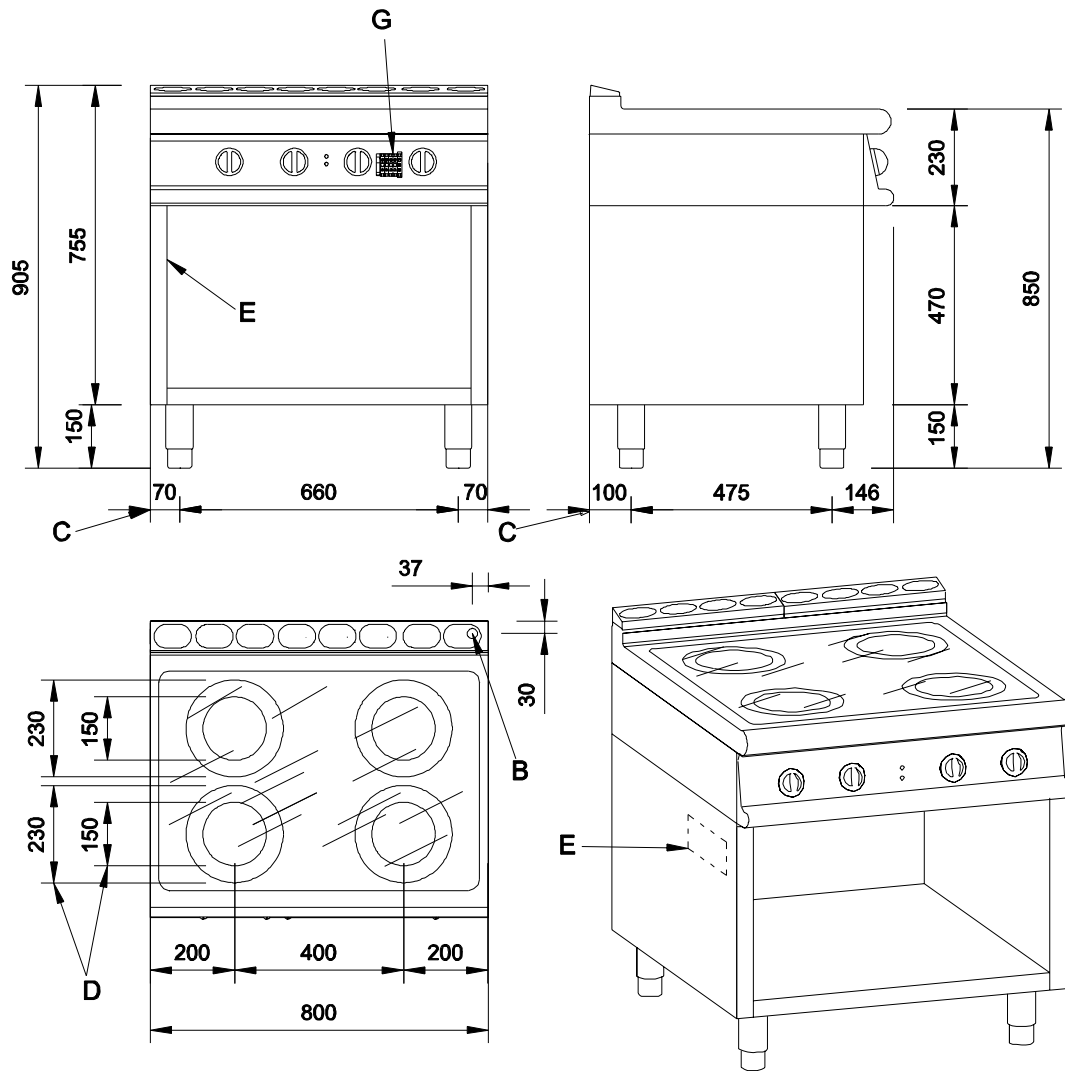

B	Fitting electric connection cable
C	Distance between feet
D	Cooking zone diameter
E	Plate
G	Terminal block

Technical specifications

Installation drawing 7NPCF/VCE800

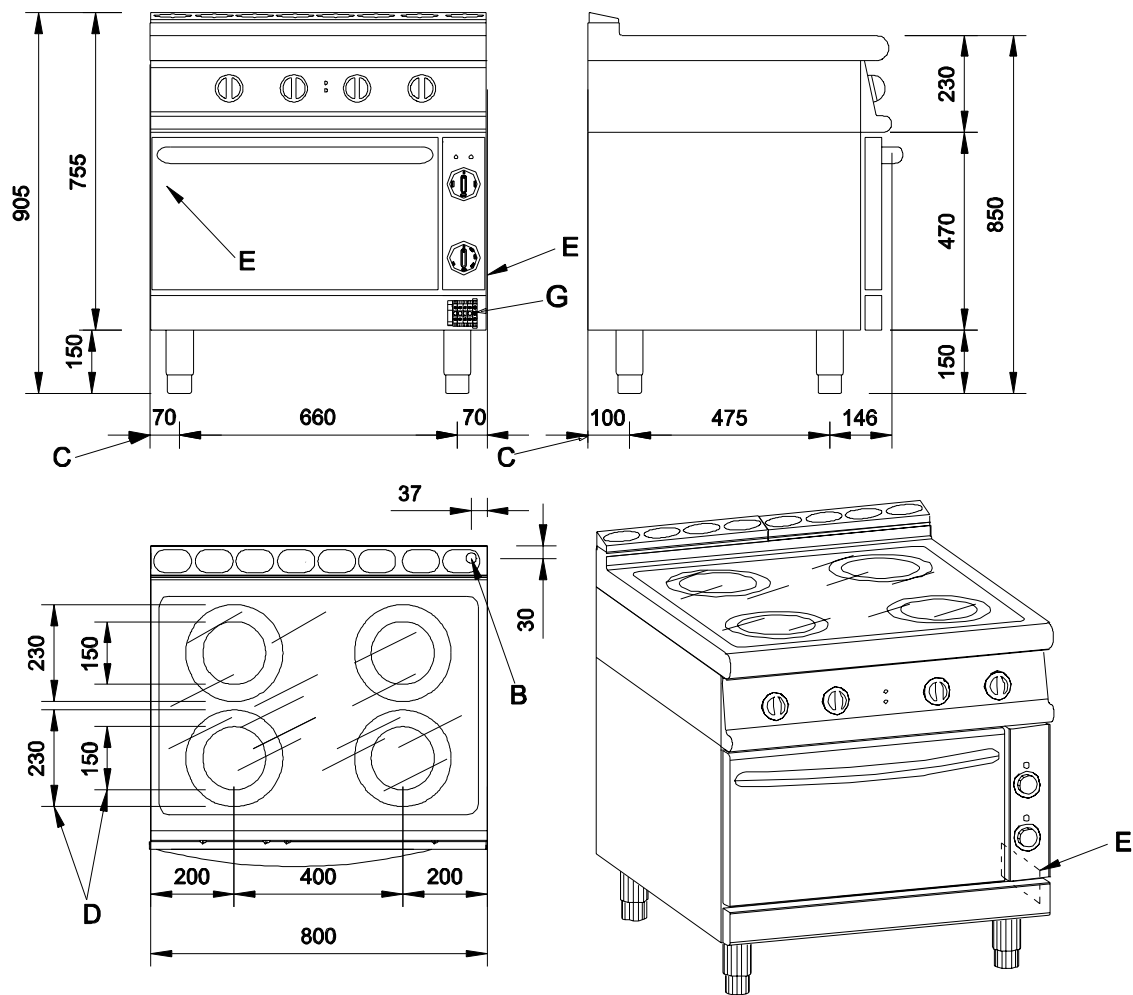

B	Fitting electric connection cable
C	Distance between feet
D	Cooking zone diameter
E	Plate
G	Terminal block

Technical specifications

Installation drawing 7NPC/VCE400

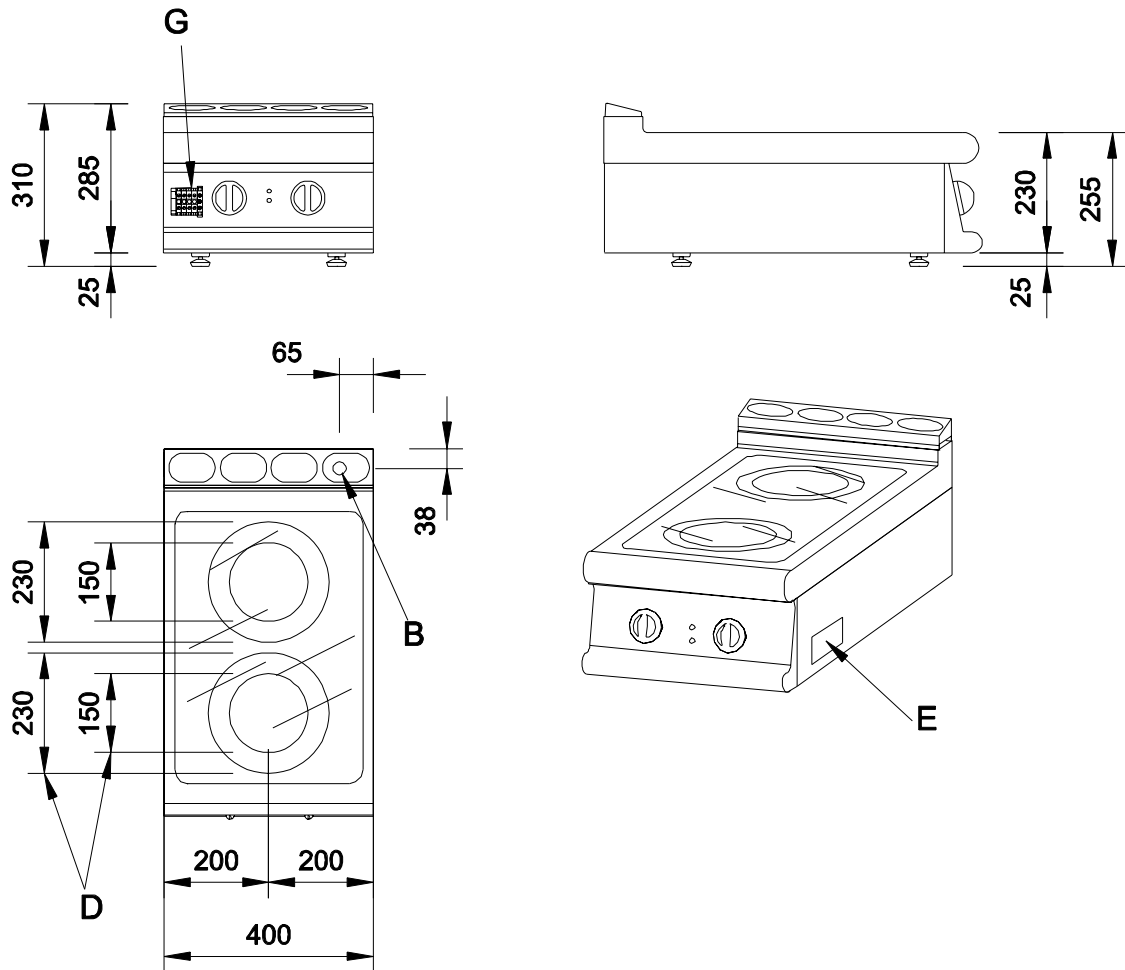

B	Fitting electric connection cable
D	Cooking zone diameter
E	Plate
G	Terminal block

Installation drawing 7NPC/VCE800

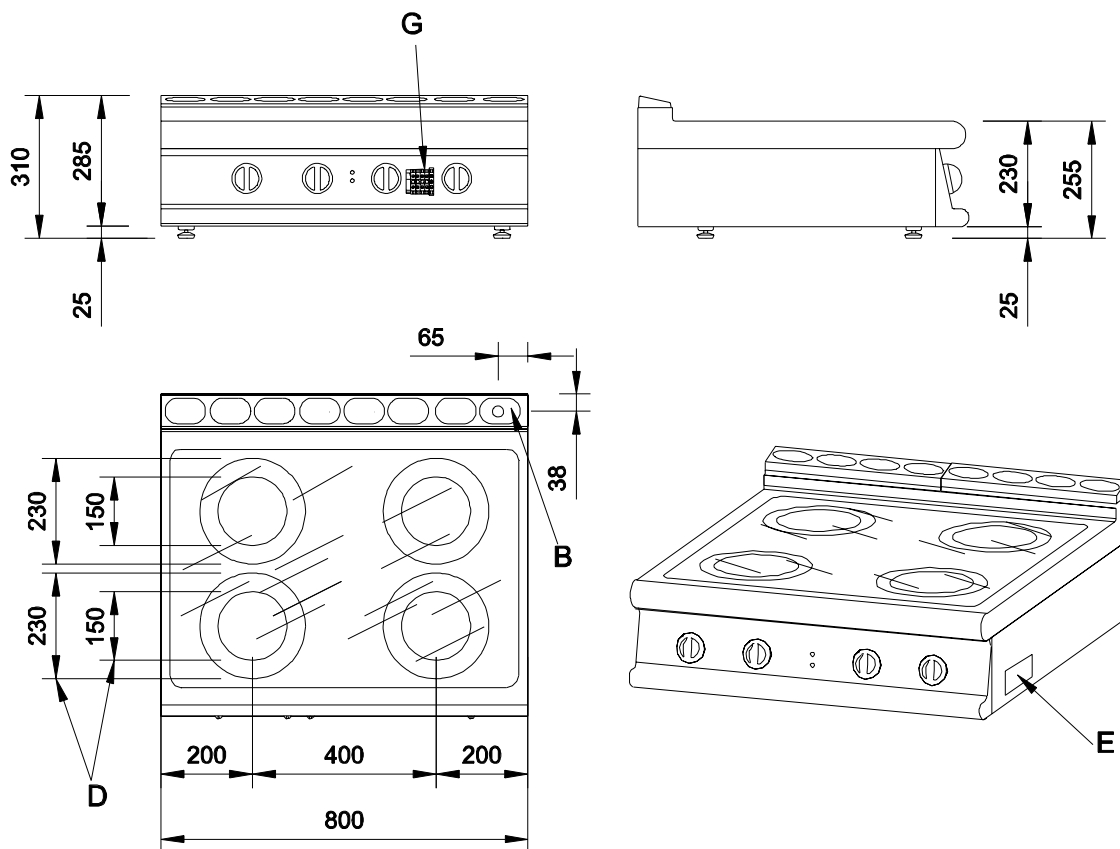

B	Fitting electric connection cable
D	Cooking zone diameter
E	Plate
G	Terminal block

Technical specifications

Item	Type	Voltage	Specification
External dimensions WxDH, freestanding unit	72B,72BP		400x700x850/900 mm
External dimensions WxDH, freestanding unit	74B,74FB,74BP		800x700x850/900 mm
External dimensions WxDxH, tabletop unit	72TB		400x700x230 mm
External dimensions WxDxH, tabletop unit	74TB		800x700x230 mm
Inner oven dimensions	74FB		536x565x255 mm
Cooking zone dim.	72B,72TB,72BP		o230x2 - o150x2
Cooking zone dim.	74B,74TB,74FB,74BP		o230x4 - o150x4
Volume with package	72B,72BP		0,4 m ³
Volume with package	74B,74FB,74BP		0,75 m ³
Volume with package	72TB		0,17 m ³
Volume with package	74TB		0,30 m ³
Total weight	72B,72BP		54 Kg
Total weight	74B,74BP		76 Kg
Total weight	74FB		120 Kg
Total weight	72TB		35 Kg
Total weight	74TB		50 Kg
Electric oven power	74FB		6 kW
Heating power o150			1,1 kW
Heating power o230			1,4 kW
Rated output	72B,72TB,72BP		5 kW
Rated output	74B,74TB,74BP		10 kW
Rated output	74FB		16 kW
Max. current	72B,72TB,72BP	A	10,9 A
Max. current	72B,72TB,72BP	H	18,9 A
Max. current	74B,74TB,74BP	A	21,7 A
Max. current	74B,74TB,74BP	H	28,8 A
Max. current	74FB	A	28,3 A
Max. current	74FB	H	45,3 A
Wire cross section	72B,72TB,72BP	A	5 x 1.5 mm ²
Wire cross section	72B,72TB,72BP	H	4 x 2.5 mm ²
Wire cross section	74B,74TB,74BP	A	5 x 4 mm ²
Wire cross section	74B,74TB,74BP	H	4 x 6 mm ²
Wire cross section	74FB	A	5 x 6 mm ²
Wire cross section	74FB	H	4 x 10 mm ²
Supply voltage		A	3/N/PE ~400V 50Hz
Supply voltage		H	3/PE ~230V 50Hz

72TB=7NPC/VCE400, 72B=7NPCV/VCE400, 72BP=7NPCVP/VCE400, 74TB=7NPC/VCE800, 74B=7NPCV/VCE800, 74BP=7NPCVP/VCE800, 74FB=7NPCF/VCE800

A=3/N/PE~400/230V 50Hz, H=3/PE~230V 50Hz

