



# **SERIE 700**

Gas-heated Fryers

A.G.A. Approval No. 6740

Model. 7FRI/G415  
7FRI/G610  
7FRI/G815

AUSTRALIAN DISTRIBUTORS :  
SCOTS ICE AUSTRALIA PTY LTD  
UNIT 8/13 BERRY STREET  
CLYDE, N.S.W 2142

**For service and maintenance contact:**

FREE CALL : 1800 222 460

EMAIL : [info@scotsice.com.au](mailto:info@scotsice.com.au)

WEB : [www.scotsice.com.au](http://www.scotsice.com.au)

**INSTRUCTION FOR INSTALLATION, ADJUSTEMENT, USE AND MAINTENANCE**

---

**CONTENTS**

<b>1- INSTRUCTIONS FOR INSTALLATION</b>	page 3
1.1 Identifying the models	page 3
1.2 Technical data	page 3
<b>2 - GENERAL INSTRUCTIONS</b>	page 3
2.1 Installation	page 3
2.3 Assembling	page 3
2.4 Aligning the equipment	page 3
2.5 Connecting to the gas supply	page 3
<b>4 - STARTING</b>	page 4
4.1 Checking the operation	page 4
4.2 Checking the thermal power	page 4
4.3 Checking the gas feeding pressure	page 4
<b>5 - CHECK OF SOME MALFUNCTIONS</b>	page 4
5.1 The pilot burner shows a difficult ignition or it fails to ignite	page 4
5.2 Extinction of pilot burner during the operation	page 4
5.3 The main burners show a difficult ignition or they fail to ignite	page 4
5.4 Difficult control of temperature	page 4
<b>6 - REPLACING SOME COMPONENTS</b>	page 4
Main burner - Pilot burner - Thermocouple - Ignition plug of pilot burner Gas valve - Safety thermostat	
<b>7- USE AND MAINTENANCE</b>	page 4
7.1 Warning	page 4
7.2 Safety devices	page 5
7.3 Use of the fryer	page 5
7.4 Lighting the burners	page 5
7.5 Extinction of burners	page 5
7.6 Draining the oil	page 5
<b>8 - CLEANING AND MAINTENANCE</b>	page 5
<b>9 - LIST OF SPARE PARTS</b>	page 5
<b>10 - ENCLOSURES</b>	page 6 - 9

**WARNING**

**- DO NOT STORE FLAMMABLE MATERIALS IN OR NEAR THIS APPLIANCE**

**- DO NOT SPRAY AEROSOLS IN THE VICINITY OF THIS APPLIANCE WHILE IT IS IN OPERATION**

**1 - INSTRUCTIONS FOR INSTALLATION**

1.1 Identifying the models

		Serie 700
Fryer with 1 basin of 15 litres	7FRI/G415	41803135222.AU
Fryer with 2 basins of 10 litres	7FRI/G610	41803135432.AU
Fryer with 2 basins of 15 litres	7FRI/G815	41803135642.AU

1.2 Technical data

The technical data of these fryers are indicated in the **Tables T1-T2**(refer to the Enclosures).

**2 - GENERAL INSTRUCTIONS**

Read the instructions of this handbook carefully because they supply important information on installation, use and maintenance safety. Keep this handbook for any further reference of the various operators. The installation, transformation and maintenance of this equipment must exclusively be carried out by authorised installers or by licensed gasfitters complying with [AS/NZS 5601](#) Gas Installation standards and any local authority requirements in force.

**The Manufacturer declines any liability if these rules are not complied with.**

N.B. – This equipment complies with the CEI standard 61-50 and AS4551.

2.1 Installation

- After unpacking, check that the equipment is intact. In case of any doubt, do not operate this apparatus and call immediately a professional engineer.
- Arrange the packing elements far from children, because they can be dangerous.
- The equipment must definitively be installed in the position it occupies in the kitchen, preferably under an exhausting hood for a proper recirculation of air.
- The equipment must be installed only in rooms with good ventilation in accordance with the installation standards [AS/NZS 5601](#)
- **Any commercial equipment of the type** must be installed only in rooms with a good exhaust system, according to the technical rules in force.
  - Refer to the data plate on the appliance for relevant technical information e.g gas type, consumption, test point pressure, etc.
- These ranges can be installed separately, or assembled with other equipment of our line.
- This range is not available in built-in version.
- The equipment must be positioned at least 10 cm far from any wall surrounding it. Install the appliance in a non-combustable area. Ensure areas are suitably insulated if required in accordance with the installation standard [AS/NZS 5601](#)
- The overall dimensions of the equipment are indicated in the following pages.
  - Do not install fryer in a marine environment

2.3 Assembling

- Remove the protection film from the outer surfaces of the apparatus. Clean these surfaces from probable residual adhesive using a proper solvent.
- Level the apparatus turning the proper adjustable feet.
- In stand-alone version, the fryer has a width of 40 cm and it must be fixed to the floor with the proper flanges (Fig. 3).

2.4 Aligning the equipment (Fig. 2)

Operate as follows:

- Remove the knobs and the control board of the top.
- Arrange the apparatuses side by side and level at the same height.
- Fasten the apparatuses with the proper screws, as shown in the fig. 2.

**2.5 Connecting to the gas supply Important!**

- Clean the pipes to remove any dust, dirt or foreign matter which could block the supply.
- Do not use pipes of a diameter smaller than that for which the appliance is designed. Ensure installation is "pipesized" for the whole installation.
- After installation the pipework, connections and appliance(s) should be checked for gas leaks in accordance with standard operations. Use soapy water to check connections for leaks.

**Warning: Do not use naked flame to check for gas leaks!**

- Make certain the appliance is arranged for the type of gas to be used. Otherwise the appliance will have to be converted to the applicable gas type. If not certain contact local gas supplier for confirmation of gas type. Any conversion to be carried out must be undertaken by an authorised person in accordance with the supplied instructions.

- Use of Flexible Hoses: Where it is intended to connect the appliance to the gas supply using a flexible, it is important to use the correct type assembly for the application. Refer to AS5601 for hose connection requirements. The hose assembly must comply with AS/NZS1869 – Class B and be kept as short as possible. A chain must be fitted to restrict the appliance movement to no more than 80% of the hose length.

- The section of the gas supply line must be sufficient to ensure the gas flow necessary for full operation of all of the appliances connected to the piping. Ensure an isolation valve and union is fitted at the inlet piping of the appliance.

[For Natural gas and LPG appliances, the regulator supplied with the appliance must be fitted between the gas valve and the appliance inlet.](#)

- The constant outlet pressure will be guaranteed by the gas pressure regulator that regulates varying inlet pressures.

- When the regulator is fitted, it must be adjusted to the correct pressure when the burners are operating.

Test point pressures are: 1.0kPa for Natural Gas

2.65kPa for L.P.G. (Propane)

[Checking the Test Point Pressure](#)

according to that given on the data plate.

- The supply pressure must be measured with the appliance operating, using a manometer (min 0.1kPa).
- Ensure gas is turned off.
- Remove control panel.
- Remove test point screw from the pressure test point and connect the manometer.

- Turn the gas on slowly, light the applicable burners and compare the value read on the manometer with that given on the data plate.
- If the manometer gives a pressure outside the range adjust the gas regulator supplying the appliance. If the pressure cannot be

adjusted to the correct value check the installation to determine problem.

#### 4 - STARTING

##### 4.1 Checking the operation

Start the equipment according to the **instructions of use**, and check:

- the correct operation of pilot and main burners;
- that there are no leaks;
- the correct operation of room ventilation systems;
- the efficiency of the exhaust gas system; if necessary, refer to the paragraph 5 "**Check of some malfunctions**";
- whether the data of the rating plate of the equipment correspond to those of the gas pipe network.

**Warning: during the operation, take extreme care in handling the hot areas of the outer surface.**

##### 4.2 Checking the thermal power

After installing the equipment and adapting it to another gas group or in any maintenance operation, check the thermal power.

- The thermal power rating is indicated in the tables **T1 – T2**.
- The equipment operates at the power rating when its nozzles actually correspond to the type of gas supplied and to the operating pressure indicated in the tables **T1 and T2**.

##### 4.3 Checking the gas feeding pressure

- Necessary measuring instrument: pressure gage with minimum accuracy rating of 0.2 mBar.
- Open the door of the compartment under the cooking basin.
- Remove the tight screw of the pipe tap **P** (see fig. 1) and connect the pipe of the pressure gage to this tap.
- Carry out the measurement while the equipment is operating.
- The measured value must be included within the limits indicated in the table **T1**; otherwise, stop the test and call the gas service company.
- Disconnect the pipe of the pressure gage and screw down the screw of the pipe tap tightly.

#### 5 - CHECK OF SOME MALFUNCTIONS

##### 5.1 The pilot burner shows a difficult ignition or it fails to ignite

- The piezoelectric lighter, the ignition plug or the pilot burner cable are faulty.
- Insufficient gas feeding pressure.
- Nozzle or pipe clogged.
- The gas valve is faulty.

##### 5.2 Extinction of pilot burner during the operation

- The thermocouple is faulty, or it is not properly heated, or not correctly connected to the gas valve.
- Gas feeding pressure drop.
- Intervention of the safety thermostat of manual reset (refer to the point 6.4)
- The gas valve is faulty.

##### 5.3 The main burners show a difficult ignition or they fail to ignite

- Insufficient gas feeding pressure.
- Nozzles clogged.
- The gas valve is faulty.
- Intervention of the safety thermostat of manual reset (refer to the point 6.4).

##### 5.4 Difficult control of temperature

- The gas valve is faulty.

#### 6 - REPLACING SOME COMPONENTS

**N.B.:** The sealed components must not be tampered with. After any operation, check that there are no leaks, if necessary.

**Warning!** Servive work must only be carried out by **Authorised Persons**.

##### 6.1 Main or pilot burners

- Open the doors of the compartment under the cooking basin.
- Replace the component.

##### 6.2 Thermocouple, high-voltage ignition cable

- Open the doors of the compartment under the cooking basin.
- Remove the control board.
- Disconnect this component from the gas valve
- Remove and replace the component.

##### 6.3 Gas valve

- Open the doors of the equipment, drain all the oil from the concerned basin (refer to the paragraph 7.6 - Draining the oil).
- Unscrew the stuffing box from the frontal panel of the basin, to extract the bulb of the valve having to be replaced.
- Remove the control board.
- Disconnect the pipes and the thermocouple of the valve and replace the valve.

##### 6.4 Safety thermostat

**Before enabling the safety thermostat **TS** (fig. 1) again**, eliminate the reasons provoking the overheating: examine the functioning of the operating thermostat, the oil level, etc... Then carry out the following operations:

- Remove the control board.
- Press the red pushbutton of the thermostat.
- Check whether the electric circuit is closed.

**Replace the safety thermostat through the following operations:**

- Open the doors of the equipment, drain all the oil from the concerned basin (refer to the paragraph 7.6 - Draining the oil).
- Unscrew the stuffing box from the frontal panel of the basin, to extract the bulb of the thermostat having to be replaced.
- Remove the control board.
- Disconnect the electrical connections and replace the thermostat.

#### 7 - USE AND MAINTENANCE

##### 7.1 Warning

This equipment has been designed for professional aims, therefore it must be operated exclusively by trained personnel.

It must exclusively be used to fry food; consequently any other use is improper.

Before switching on the cooker, clean all its surfaces in contact with food, with the utmost care.

**ATTENTION ! Never switch on the fryer when its basins have no oil. When using cakes of fat, first of all melt them adjusting the temperature to the MINIMUM (turn the knob M of the fig. 1 to 1).**

**Never exceed the maximum level of oil marked inside the basin.**

It is better to attend the equipment during the operation, because possible faults of the safety devices could provoke the overheating of the oil contained in the basin, that becomes inflammable at high temperatures.

Dip the basket with the food to fry, slowly into the boiling oil taking care that the froth being generated does not overflow from the rim of the basin. If this happens, stop dipping the basket for some seconds. The installation and possible transformation of these fryers for other gas groups must be carried out only by authorized and qualified installers.

In case of troubles, close the gas cutoff cock, installed before the equipment.

For any repair, call the authorized After-Sales Service and require only original spare parts.

**Not complying with these instructions may seriously compromise the safety of this equipment; the manufacturer declines any liability in case these warnings are not complied with.**

### 7.2 Safety devices

Any basin of these fryers is provided with a safety thermostat. When the maximum control temperature is exceeded, this thermostat cuts off the gas flow. When this occurs, close the cutoff cock installed before the equipment, and call an After-Sales Centre.

### 7.3 Use of the fryer (fig. 1)

The knob **M** of the valve is marked with the following symbols:

- Pilot burner on and off**
- 1** **Minimum cooking temperature**
- 2 - 6** **Intermediate cooking temperatures**
- 7 - 8** **Maximum cooking temperature**

### 7.4 Lighting the burners (Fig. 1)

- Fill the basin with oil until its level is above the minimum mark and below the maximum mark, refer to pan for oil level markings.
- Turn the knob **M** to .
- Press the button **A** completely and light the pilot burner pressing the button of the piezoelectric lighter **AP**.  
After lighting, keep the button **A** pressed for approximately 20 seconds (observe the pilot burner opening the doors of the equipment).
- In case of extinction of the pilot burner, repeat this operation.
- Turn the knob **M** to the position corresponding to the desired temperature.

### 7.5 Extinction of burners (fig. 1)

- Switch off the main burner turning the knob **M** to the position
- Switch off the pilot burner turning the knob **M** to the position and pressing the button **S** (fig. 1).

### 7.6 Draining the oil

- The oil drain cock **S** (fig. 1) - one cock per basin - is installed inside the compartment under the cooking basins, in a safe position so that it cannot accidentally be opened during the operation.
- When draining the basin, put the proper tray (or other vessels being able to contain the quantity of oil to be drained at high temperature) under the drain cock.

## **8 - CLEANING AND MAINTENANCE**

- Wash the surfaces of stainless steel with water and non abrasive detergents, every day; then rinse abundantly and wipe carefully.
- When cleaning stainless steel, never use detergents with abrasive substances, nor steel wool, brushes or scrapers of common steel.
- Clean the floor under the fryer with non corrosive products.
- Do not wash the equipment with water jets.

When the equipment must not be used for long time, comply with the following instructions:

- Close the gas cutoff cock, installed before the equipment.
- Clean all the surfaces carefully.
- Protect the surfaces of stainless steel laying off a light film of white mineral oil with a cloth.
- Ventilate the rooms periodically.
  - Check the equipment periodically (at least once a year); this check must be carried out by qualified professional personnel. Drawing up a maintenance contract is recommended.

**It is recommended the appliance be visually checked for problems each week and the appliance be serviced by an authorised service person at least every 12 months or as may be required. This is not covered by warranty.**

## **9 - LIST OF SPARE PARTS**

- Gas control valve
- Pilot burner
- Main burner
- Thermocouple
- Ignition plug of pilot burner
- Safety thermostat
- Piezoelectric lighter
- Oil drain cock.

<b>T1</b>		<b>Serie 700</b>		
		41803135222.AU	41803135432.AU	41803135642.AU
<b>Modelli - Modelle - Models</b>		7FRI/G415	7FRI/G610	7FRI/G815
<b>Modèles - Modellen</b>		50 MJ/h natural gas	72 MJ/h natural gas	100 MJ/h natural gas
<b>Q Mj</b>		45 MJ/h LPG propane	65 MJ/h LPG propane	90MJ/h LPG propane
Consumo gas**				
Nat Gas	1 kPa	1.38	2.01	2.75
	m <sup>3</sup> /h			
L.P.G	2,65 kPa	1.03	1.49	2.05
	kg/h			
<b>Tipo - Bauart - Type</b>		<b>A<sub>1</sub></b>	<b>A<sub>1</sub></b>	<b>B<sub>11</sub></b>
<b>Bauart für DE</b>		<b>A<sub>1</sub></b>	<b>A<sub>1</sub></b>	<b>B<sub>11</sub> - B<sub>21</sub></b>
Connessione gas* ISO 7/1 R 3/4 #				

\*\* Consumo gas - Gasverbrauch - Gas consumption - Consommation du gaz - Gasverbruik

\* Connessione gas - Gasanschluss - Arrivée gaz - Verbindung

# Per installazione in Danimarca occorre avvitare sulla rampa d'alimentazione l'apposito nipplo.

# Vor dem Anschluß an die Gasversorgungsanlage, ist es erforderlich, den als Ausstattung gelieferten passenden Nippel auf Versorgungsrampe gas einzuschrauben.

## T2 Serie 700

Gas	P kPa	<b>Modelli-Modelle-Models</b> <b>Modèles-Modellen</b>	41803135222.AU 7FRI/G415	41803135432.AU 7FRI/G610	41803135642.AU 7FRI/G815
Nat Gas	1	Ugelli pilota o	32.2	2 x 32.2	2 x 32.2
		Ugelli bruciatore p	2 x 250	4 x 200	4 x 250
		A= mm r	20	20	20
L.P.G	2,65	Ugelli pilota o	16.2	2 x 16.2	2 x 16.2
		Ugelli bruciatore p	2 x 130	4 x 110	4 x 130
		A= mm r	10	5	10

o Ugello pilota - Zündbrennerdüse - Pilot burner nozzle - Injecteur de la veilleuse - Gaspitten pilot

p Ugello bruciatore - Brennerdüse - Burner nozzle - Injecteur du brûleur - Gaspitten brander

q Tutta aperta - Offen - Complètement ouvert - Completely open

r A= Regolazione aria primaria - Primärluftabstand - Primary air adjustment - Regulation de l'air - Regeling aanfangslucht

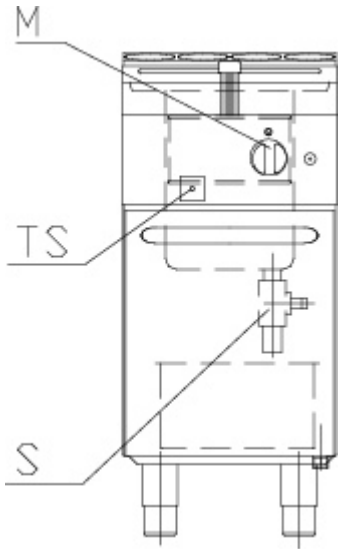

Fig.1 - Abb. 1

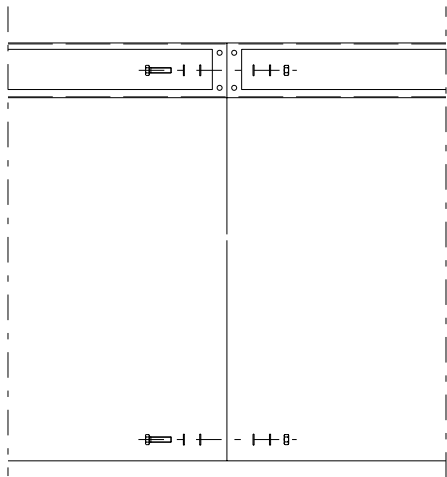

Fig.2 - Abb.2

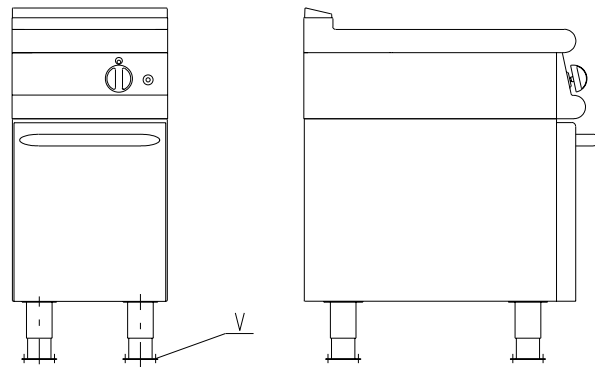

Fig.3 - Abb. 3

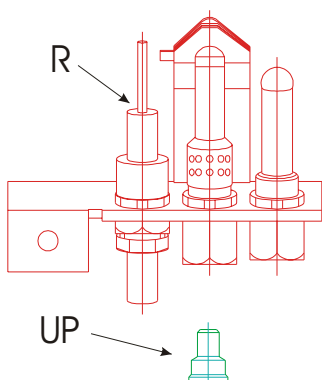

Fig. 4 - Abb. 4

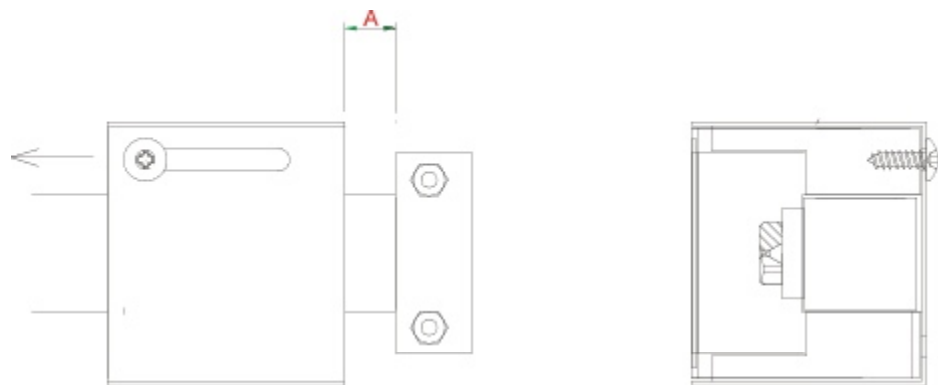
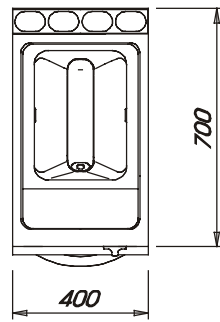
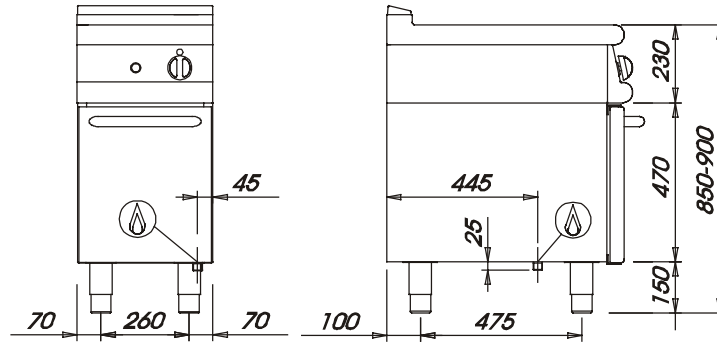
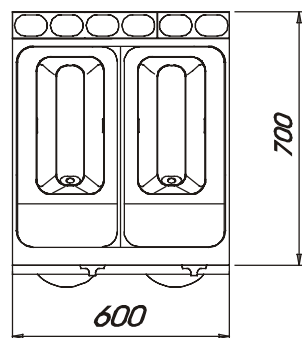
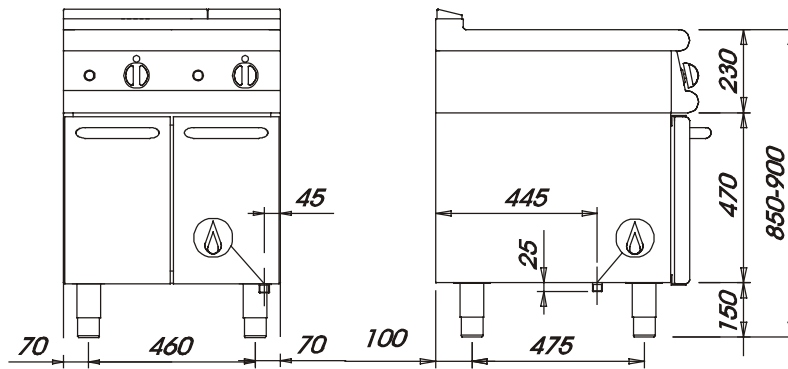

Fig. 5 - Abb. 5



7FRI/G415  
41803135222.AU



7FRI/G610  
41803135432.AU

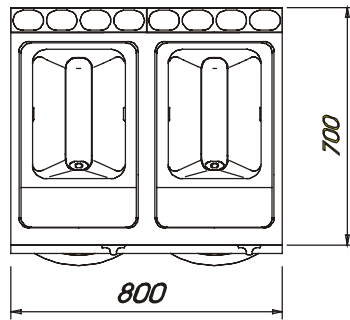
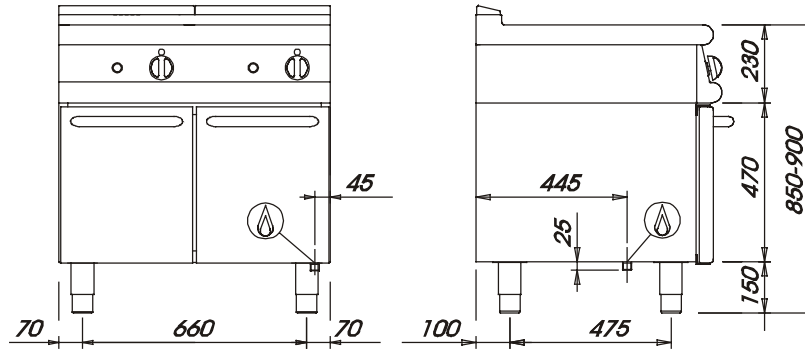

7FRI/G815  
41803135642.AU